

Product Features

Motor Type	Remote (External Mounting)
Cooking Coverage	Suits 90cm - 130cm Cooking Surfaces
Filtration Type	Baffle Filters x 3
Lighting	LED 6 x 1.2 W (3200 K)
Finish	AISI304 Scotch Brite Stainless
Controls	Touch Control (Remote Control Included)
Speed Settings	3 Speed + Boost
Timer Functions	15min Auto Shut-Off
Ducting	200mm Circular Outlet 5 x Meters of Flexi Duct Supplied
Hood Width	1200mm
Hood Depth	600mm
Hood Height	1291mm (max)

Filtration Zone



Dimensioned Drawing

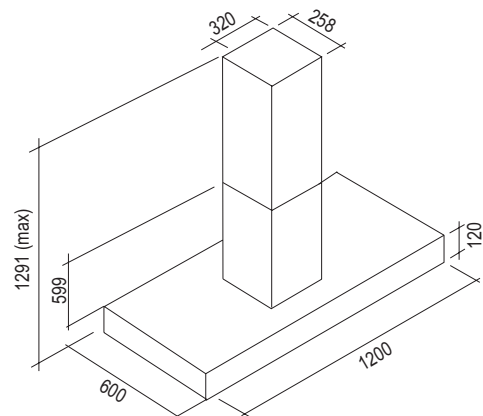

Model Code	Motor Output	Motor Solution
F7TN12S1-ER2010	2010 m ³ /hr	External Roof Motor
F7TN12S1-EW2010	2010 m ³ /hr	External Wall Motor