



Breville®

the InFizz™ Fusion

BCA800

BILT. × Breville®

Scan for
3D interactive set up



 Safety Guide

CONTENTS

- 02 - Limited product warranty
- 02 - Breville® recommends safety first
- 02 - Safety guidelines
- 04 - Components & Accessories
- 05 - Before first use - Care & Cleaning
- 06 - Gas canister placement
- 07 - Carbonating water
- 08 - Carbonating non-water drinks
- 10 - Troubleshooting

LIMITED PRODUCT WARRANTY

2 YEAR LIMITED

Breville's warranty for this product covers the repair or replacement if it's found to be defective due to faulty materials, workmanship, or function within the warranty period.

All legal warranty rights under applicable national legislation will be respected and will not be impaired by our warranty. For details on length of warranty, to obtain a printed copy or to read full terms and conditions please scan the QR code or visit www.breville.com



QR149

Alternatively, call the Breville Service Centre (see back cover for contact details)

BREVILLE® RECOMMENDS SAFETY FIRST

At Breville® we are very safety conscious. We design and manufacture consumer products with the safety of you, our valued customer, foremost in mind. In addition, we ask that you exercise a degree of care when using any appliance and adhere to the following precautions.

SAFETY GUIDELINES



Keep clean and store the bottle with the lid off.



WARNING



Never attempt to carbonate an empty bottle.



Never use a bottle that's deformed, discoloured, or scratched.



Never put the bottle in the freezer.



Don't transport the InFizz™ Fusion with the gas Canister installed.



Do not carbonate milk based products.



Do not put ice in the bottle.



Use InFizz™ Fusion compatible carbonating bottles **ONLY**.



Never clean the bottle in the dishwasher.



Do not leave the InFizz™ Fusion and/or the bottle in direct sunlight or too close to a window.



Do not place the InFizz™ Fusion next to a heat source.



Do not place the InFizz™ Fusion close to open flames of any sort.



Do not use the InFizz™ Fusion and/or the bottle in extreme temperatures.



Do not use the bottle after its expiration date.



The symbol shown indicates that this appliance should not be disposed of in normal household waste. It should be taken to a local authority waste collection center designated for this purpose or to a dealer providing this service. For more information, please contact your local council office.

CARBON DIOXIDE CO₂ CANISTER

To reduce the risk of a CO₂ leak, personal injury and property damage:

- In the event of a CO₂ leak, ventilate the area, breathe fresh air and if feeling unwell seek immediate medical attention.
- Do not insert a CO₂ Canister into the InFizz™ Fusion when a bottle is installed.

- Do not remove a CO₂ Canister from the InFizz™ Fusion when it is being operated.

- Do not remove bottle during carbonation.

- Do not handle or remove a CO₂ Canister while it is discharging CO₂.

- Do not use if damaged. Inspect the CO₂ Canister and CO₂ Canister valve prior to use for dents, punctures, or other damage. If damaged, contact an authorised service representative.

- Do not tamper with the CO₂ Canister in any way, including puncturing, incinerating or removing the valve.

- Do not expose the CO₂ Canister to heat above 120°F / 50°C. Protect from sunlight. Store in a well-ventilated area.

SAVE THESE INSTRUCTIONS FOR HOUSEHOLD USE ONLY

COMPONENTS

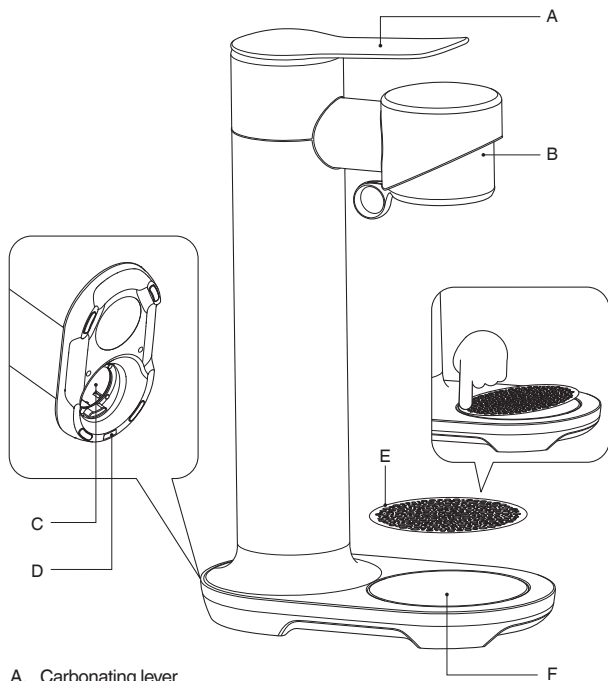

- A. Carbonating lever
- B. Tilt head with ring pull
- C. Gas cylinder compartment
- D. Flat surface safety switch to ensure a flat surface is used
- E. Removable drip tray cover (hand wash only)
- F. Drip tray

ACCESSORIES

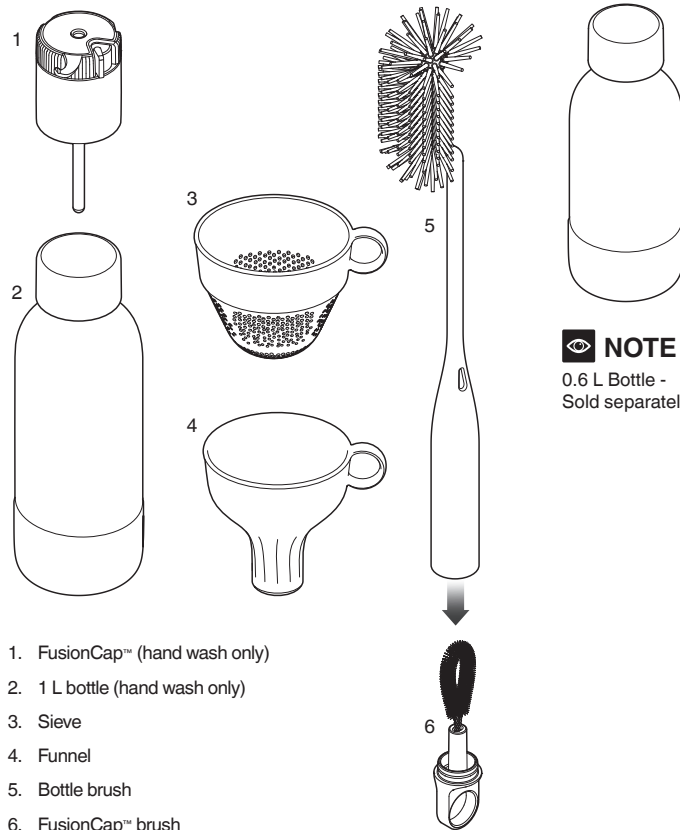

- 1. FusionCap™ (hand wash only)
- 2. 1 L bottle (hand wash only)
- 3. Sieve
- 4. Funnel
- 5. Bottle brush
- 6. FusionCap™ brush

NOTE
0.6 L Bottle -
Sold separately

1. BEFORE FIRST USE CARE & CLEANING

1.1

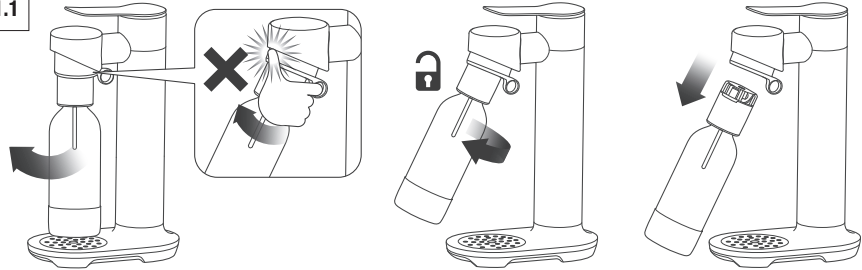

1.2

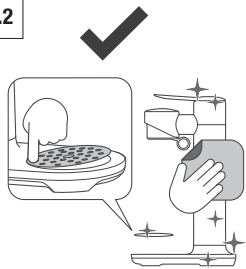

1.3

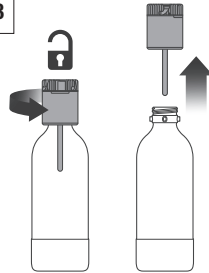

1.4

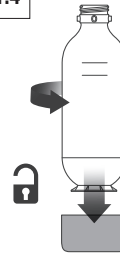

1.5

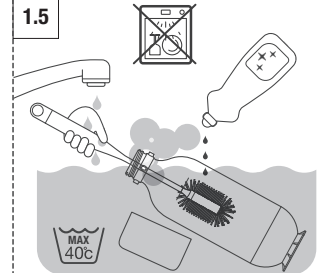

1.6

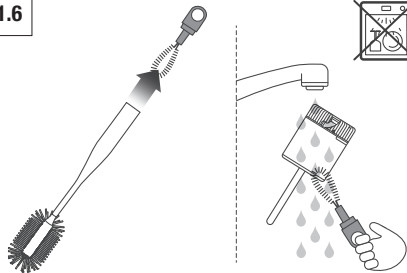

1.7



1.8

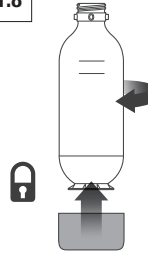

1.9



Keep clean and store the bottle with the lid off.

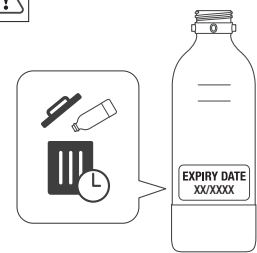

2.

GAS CANISTER PLACEMENT

2.1



Screw
Type



Quick
Connect
Type



2.2

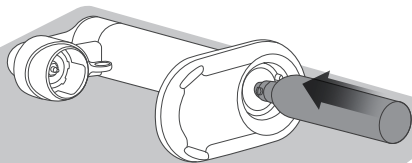

2.3

Gently turn the canister
in a clockwise motion
until screwed in.

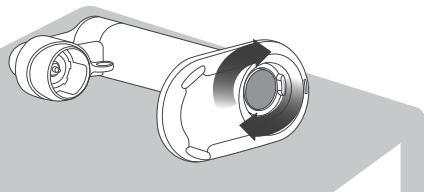

3.

CARBONATING WATER

3.1

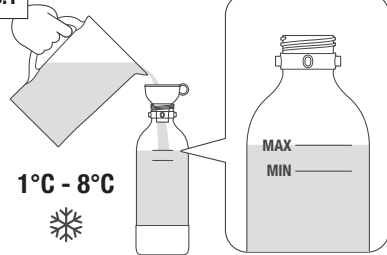

3.2

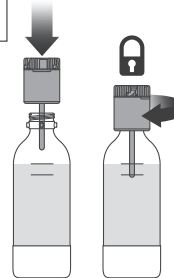

3.3

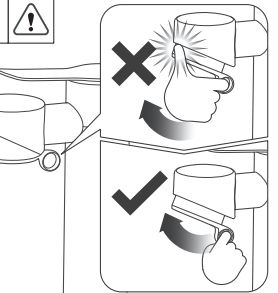

3.4

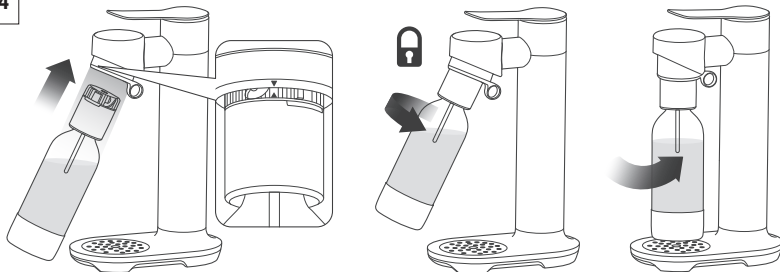

3.5

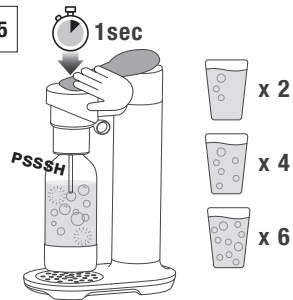

3.6

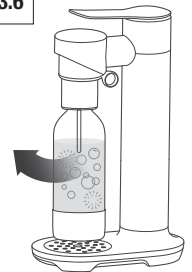

3.7

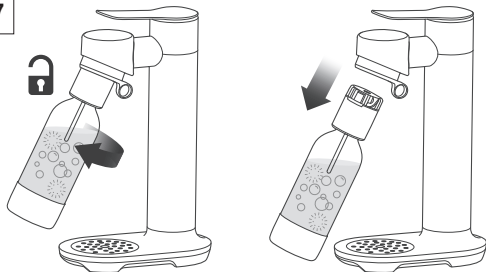

3.8

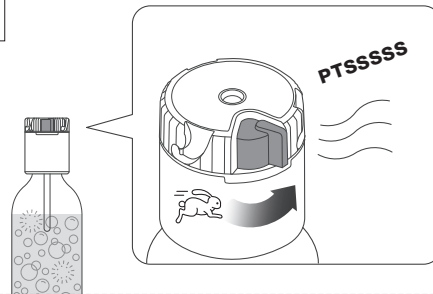

3.9

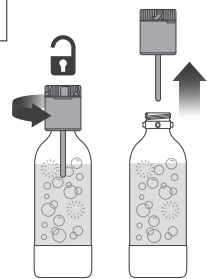

4.

CARBONATING NON-WATER DRINKS

4.1

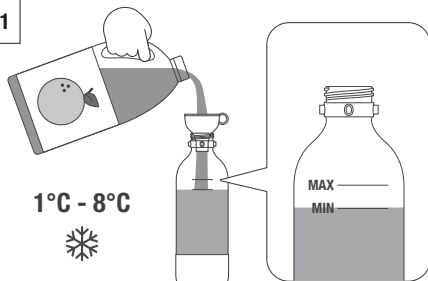

4.2

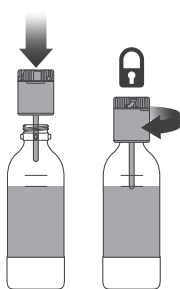

4.3

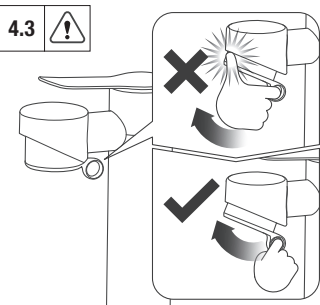

4.4

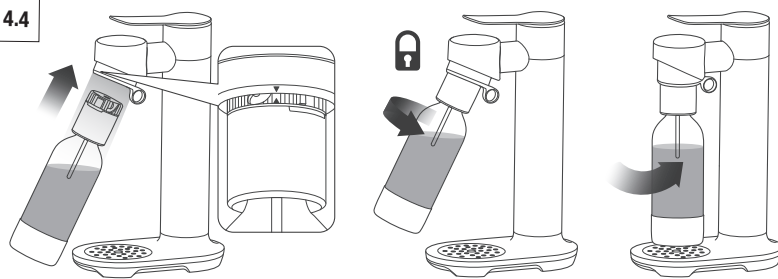

4.5

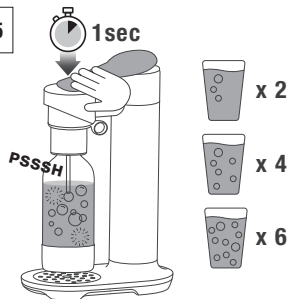

4.6

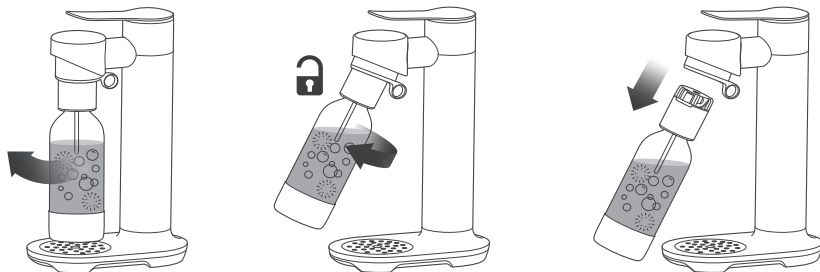

4.7

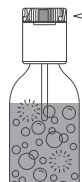

Move the switch to the center position to slowly release gas.

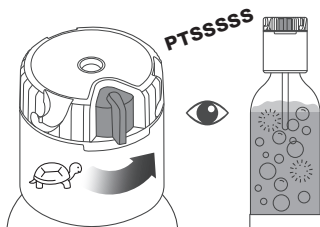

Move the switch all the way to the right when the sound of the gas releasing is no longer heard.

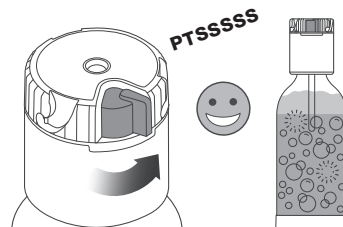

Turn the switch back to the left if the foam rises up too quickly.

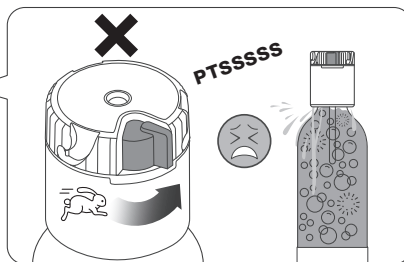
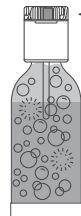
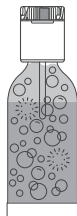
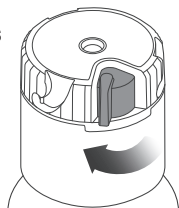

4.8

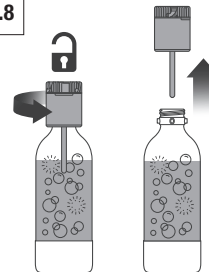

5. TROUBLESHOOTING

PROBLEM	POSSIBLE CAUSES	EASY SOLUTIONS
Small pieces of ice in the bottle.	Small pieces of ice may appear and quickly melt in the bottle while carbonating.	<ul style="list-style-type: none">• Shorten each press so the efficiency of carbonation is not affected.
Little or no carbonation.	CO ₂ canister may be near empty or empty. NOTE: Cold water also maximises carbonation.	<ul style="list-style-type: none">• Replace the canister with a full one.• Check the CO₂ canister is properly screwed into place.
Bottle cannot be removed from the FusionCap™.	Excess CO ₂ has not been fully released.	<ul style="list-style-type: none">• Turn the red switch on the FusionCap™ all the way to the right to release all of the pressure.
Juice or other non-water liquids foam up too quickly.	Non-water liquids should not be filled passed the MIN line on the bottle. Varying amounts of sugar in drinks causes them to react and carbonate differently, so short presses on the lever will minimise over foaming.	<ul style="list-style-type: none">• Turn the red switch on the FusionCap™ back to the left to slow down the pressure release. Once foam has subsided, slowly turn the switch to the center position before turning all the way to the right.

TIP

Soak the FusionCap™ every 30 days in max 40°C water for 5 mins



6.



For more information on:

- Cleaning • Troubleshooting
- Useful Tips and Warranty

Check out the website, visit www.breville.com

BILT.® × Breville®

Scan for
Troubleshooting



Breville Service Center

Australian Customers

Phone: 1300 139 798

Web: www.breville.com

New Zealand Customers

Phone: 0800 273 845

Web: www.breville.com

Breville®

Master Every Moment™

Breville, the Breville Logo, is a trademark of Breville Pty Ltd ("Breville") and Breville's products are distributed in Australia and New Zealand under license. Copyright Breville Pty. Ltd. 2023.

Due to continued product improvement, the products illustrated/photographed in this brochure may vary slightly from the actual product.