

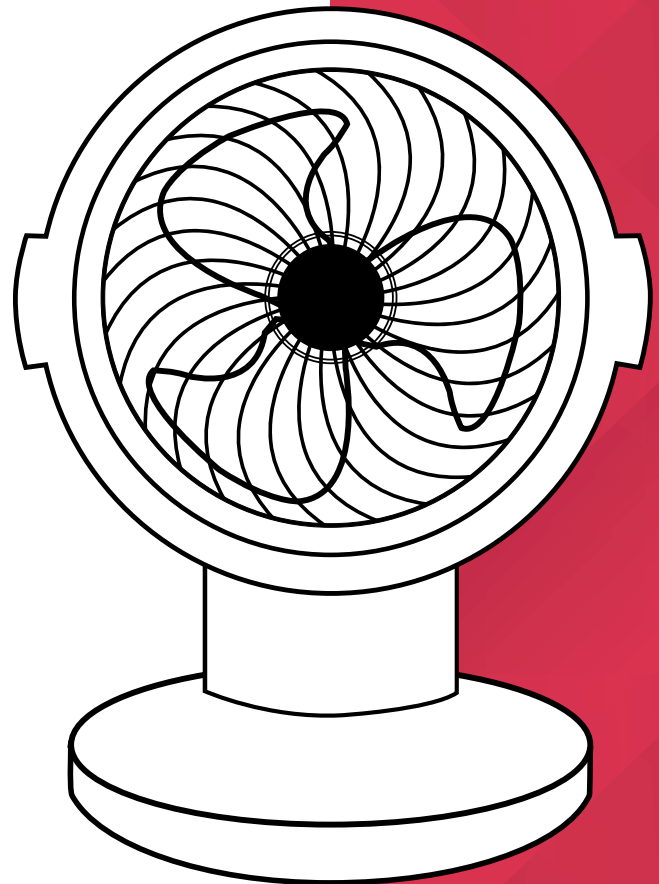

INSTRUCTION MANUAL



Air Circulator Fan

Model: DCAC30HC

For domestic household use only.



IMPORTANT

THESE INSTRUCTIONS SHOULD BE READ CAREFULLY AND RETAINED FOR FUTURE REFERENCE.

Note also the information presented on the appliance

CAUTION: FAILURE TO FOLLOW THESE INSTRUCTIONS MAY CAUSE INJURY AND/OR DAMAGE AND MAY INVALIDATE YOUR WARRANTY

Please read the operating instructions carefully before using your air circulator for the first time and keep them in a safe place.

WARNING - This appliance must not be used in a bathroom.

WARNING - Do not use this appliance in the immediate surroundings of a bath, a shower or a swimming pool.



WARNING - In order to avoid overheating, do not cover this heater.

WARNING - Do not use this heater in small rooms when they are occupied by persons not capable of leaving the room on their own, unless constant supervision is provided.

WARNING - To reduce the risk of fire, keep textiles, curtains, or any other flammable material a minimum distance of 1 metre from the air outlet.

WARNING - In order to avoid a hazard due to inadvertent resetting of the thermal cut-out, this appliance must not be supplied through an external switching device, such as a timer, or connected to a circuit that is regularly switched on and off by the utility.

WARNING - Some parts of this unit can become very hot and cause burns. Particular attention has to be given where children and vulnerable people are present.

- If the supply cord is damaged it must only be replaced by the manufacturers service agent or a similarly qualified person in order to avoid a hazard.
- This appliance is not intended for use by persons (including children) with reduced physical, sensory or mental capabilities, or lack of experience and knowledge, unless they have been given supervision or instruction concerning use of the appliance by a person responsible for their safety.
- Children should be supervised to ensure they do not play with the appliance.
- Prior to cleaning or other maintenance, the appliance must be disconnected from the supply mains.
- Never immerse the appliance in water or other liquids.
- Do not place on soft, unstable or non-horizontal/angled surfaces.
- Never operate the appliance if a cable or connector has been damaged, after appliance malfunction or if the appliance was dropped or is otherwise damaged.
- If the mains lead is damaged it must only be replaced by the manufacturers service agent or a similarly qualified person in order to avoid a hazard.

- Please ask a professional service agent to repair the product. Improper repair may cause danger to users.
- Disconnect the appliance from mains power whenever it is not in use, before relocating it, and before cleaning.
- Operate the appliance only at the voltage specified on the rating label.
- Only connect the unit to a properly installed and easily accessible socket so that you can quickly disconnect the plug if necessary.
- Do not connect this product to the mains using an extension lead.
- This air circulator is only intended for **INDOOR RESIDENTIAL** applications. This air circulator should not be used for commercial or industrial or leisure applications or in small enclosed spaces.
- Never use the mains lead as a carrying strap or pulling lead.
- To avoid a fire or electrocution hazard, **NEVER** put the cord near heat registers, radiator, stoves or heaters.
- **DO NOT** cover cord with carpeting, throw rugs, runners, or similar coverings.
- **DO NOT** route cord under furniture or appliances. Take care to position the cord away from traffic areas and where it will not be a tripping hazard.
- **DO NOT** use the unit near windows or where water collects. Rain and water collection may lead to a risk of fire or electric shock.
- **DO NOT** use this heater if it has been dropped.
- **DO NOT** use if there are visible signs of damage to the heater.
- The heater must not be located immediately below a power outlet.
- **WARNING** - To avoid danger of suffocation please remove all packaging materials particularly plastic and EPS and keep these away from vulnerable people, children and babies.
- **NEVER** drop or insert any object or fingers into any openings.
- Do not use the appliance in locations where paint, petrol or other flammable liquids are used or stored.
- Do not use bug sprays or other flammable cleansers/vapour sprays on or around the unit.
- Always switch off the unit and take the plug out of the socket:
 - If you are not using the unit
 - Before you clean or carry out maintenance on the unit
 - If a fault occurs
 - In the event of an electrical storm.
- Avoid electromagnetic interference. Keep the unit at least 1 metre away from electrical appliances such as televisions & radios.
- Use this heater on a horizontal and stable surface.
- This appliance is not intended for use by persons (including children) with reduced physical, sensory or mental capabilities, or lack of experience and knowledge, unless they have been given supervision or instruction concerning use of the appliance by a person responsible for their safety.
- Children should be supervised to ensure that they do not play with the appliance.
- Children shall not plug in, regulate and clean the appliance or perform user maintenance.



WARNING - DO NOT COVER the heater in any manner as it may overheat and become a fire risk.

WARNING: KEEP BATTERIES OUT OF REACH OF CHILDREN

- Swallowing may lead to serious injury in as little as 2 hours or death, due to chemical burns and potential perforation of the oesophagus.
- If you suspect your child has swallowed or inserted a button battery immediately call the 24-hour Poisons Information Centre on 13 11 26 (in Australia) or 0800 764 766 (in New Zealand) for fast, expert advice.
- Examine devices and make sure the battery compartment is correctly secured, e.g. that the screw or other mechanical fastener is tightened. Do not use if the compartment is not secure.
- Dispose of used button batteries immediately and safely. Flat batteries can still be dangerous.

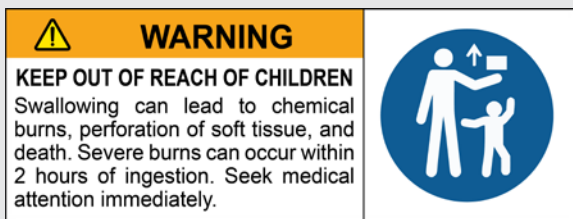

CAUTION: No obvious symptoms

Unfortunately, it is not obvious when a button or coin battery is stuck in a child's oesophagus (food pipe).

There are no specific symptoms associated with this. The child might:

- cough, gag or drool a lot
- appear to have a stomach upset or virus
- be sick
- point to their throat or stomach
- have a pain in their abdomen, chest or throat
- be tired or lethargic
- be quieter or more clingy than usual or otherwise 'not themselves'
- lose their appetite or have a reduced appetite
- not want to eat solid food/be unable to eat solid food

These types of symptoms vary or fluctuate, with the pain increasing and then subsiding.

A specific symptom to button and coin battery ingestion is vomiting fresh (bright red) blood. If the child does this seek immediate help. The lack of clear symptoms is why it is important to be vigilant with 'flat' or spare button or coin batteries in the home and the products that contain them.



Exposed to the weather outdoors



Near water



If the power cable wires are frayed or cut



Where small children may be left unattended

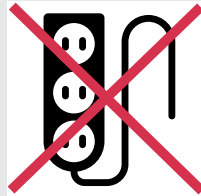

No extension leads or power boards



Where the power cable may be damaged



On a slope or uneven surface



Where there is risk of fire or close to a naked flame



Where it may be damaged by chemicals



Where there is a risk of interference by foreign objects



This product is not made for DIY repair



If there is a risk of water falling on the unit

Specification

Model no.	DCAC30HC
Power supply	220-240V~, 50Hz
Rated power	40W (cooling) 1800W (heating)
Speed settings	5 (cooling)
Heat settings	2
Timer	12 hours
Air movement	15m ³ /min
Air speed	6m/s
Vertical oscillation	70°
Horizontal oscillation	80°
Noise level (MAX)	55dB(A)
Weight (net)	3.9kg
Dimensions (w x d x h)	318 x 275 x 404.2mm

- For greater precision, please always refer to the rating label placed on the product.

How It Works

In contrast to a traditional fan which brings only cooling benefits when directly facing you; an air circulator works for any season, keeping the air in motion and making the entire room more comfortable to be in.

Most fans simply lack the aerodynamics to keep the air in the room in motion. As opposed to blowing air directly in contact with it, our Dimplex air circulators create a 3D oscillating draught in the form of an invisible jet stream.

This jet stream helps maintain a constant room temperature by ridding the room of cold and warm spots. It also clears stuffy atmospheres by circulating stale air with fresh air from an open window.

Air circulators are the safe, all-year-round temperature regulation solution you've been looking for.

Where To Position

During Summer, pointing the air circulator towards a wall halfway between the floor and the ceiling, as well as using the highest setting, will set up a high speed air circulation pattern.

This will cool down the room in an efficient manner. Pointing towards your air conditioner will help distribute the cool air faster, saving time and energy; essentially Turbo boosting your A/C.

During Winter, the use of a heater alone produces warm air that rises naturally to the ceiling.

By pointing the air circulator upwards, and utilising the lowest speed setting, the hot air will circulate with the cooler air near the floor, resulting in a more even room temperature.

Parts

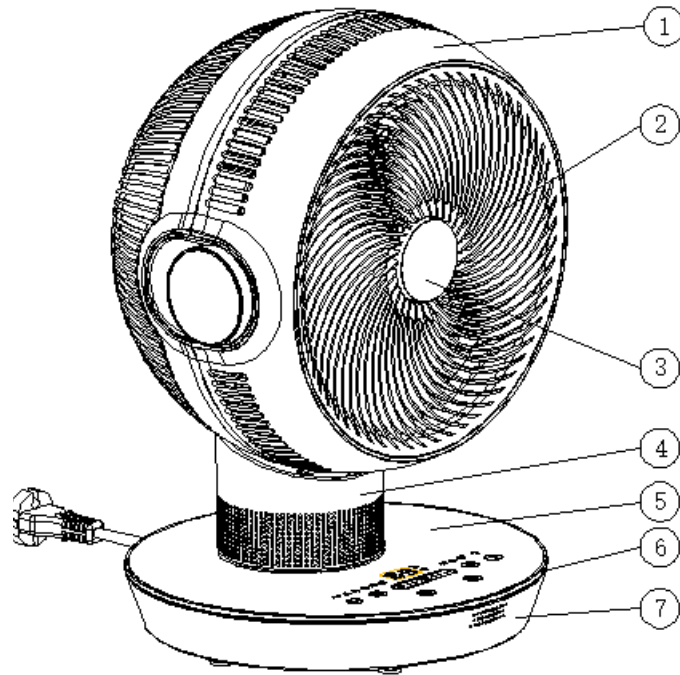

- (1) Front Shell
- (2) Front Grille
- (3) Cover
- (4) Post
- (5) PC Panel
- (6) Upper Base Cover
- (7) Lower Base Cover

- (8) Rear Shell
- (9) Handle Cover
- (10) Fixing Block
- (11) Dust Screen - Left
- (12) Dust Screen - Right
- (13) Power Cord
- (14) Manual On/Off Switch

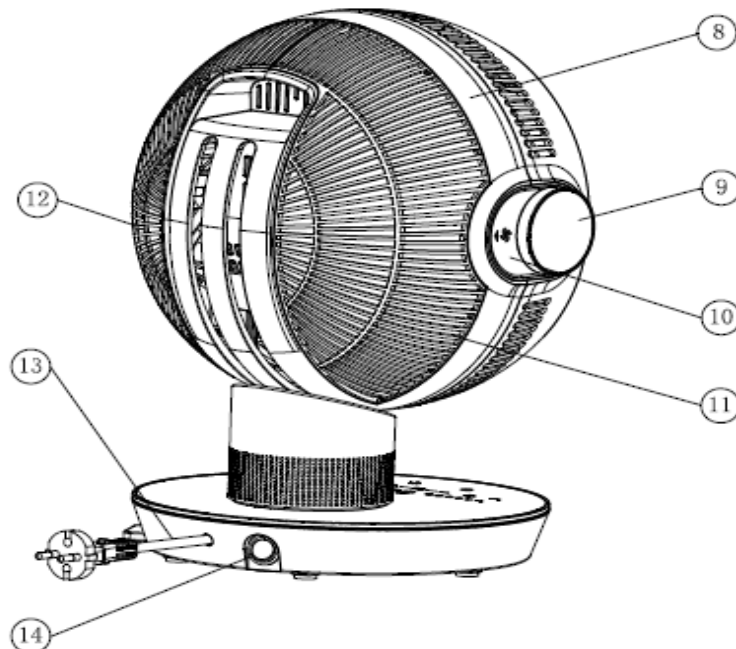

Control Panel & LED Display

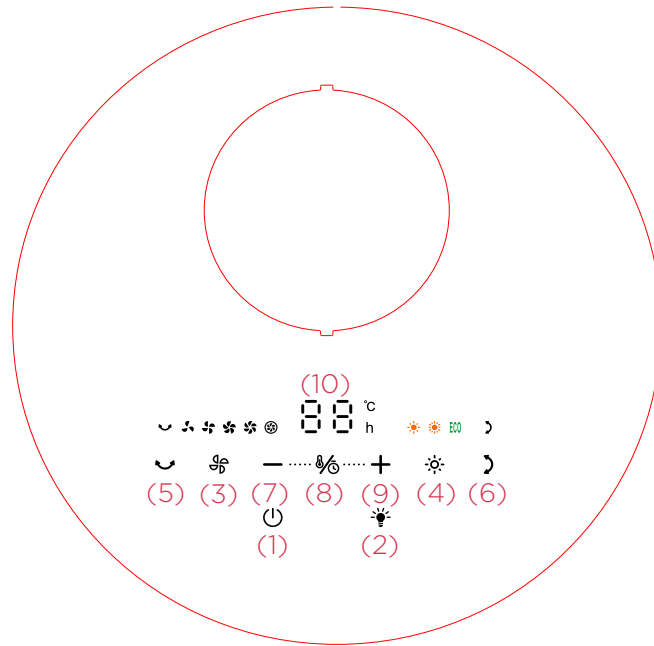

- (1) On/Off
- (2) Screen Off
- (3) Cooling Air Speed
- (4) Heating Air Speed
- (5) Horizontal Oscillation

- (6) Vertical Oscillation
- (7) Temp/Timer Decrease
- (8) Temp/Timer Function
- (9) Temp/Timer Increase
- (10) LED Display

Remote Control

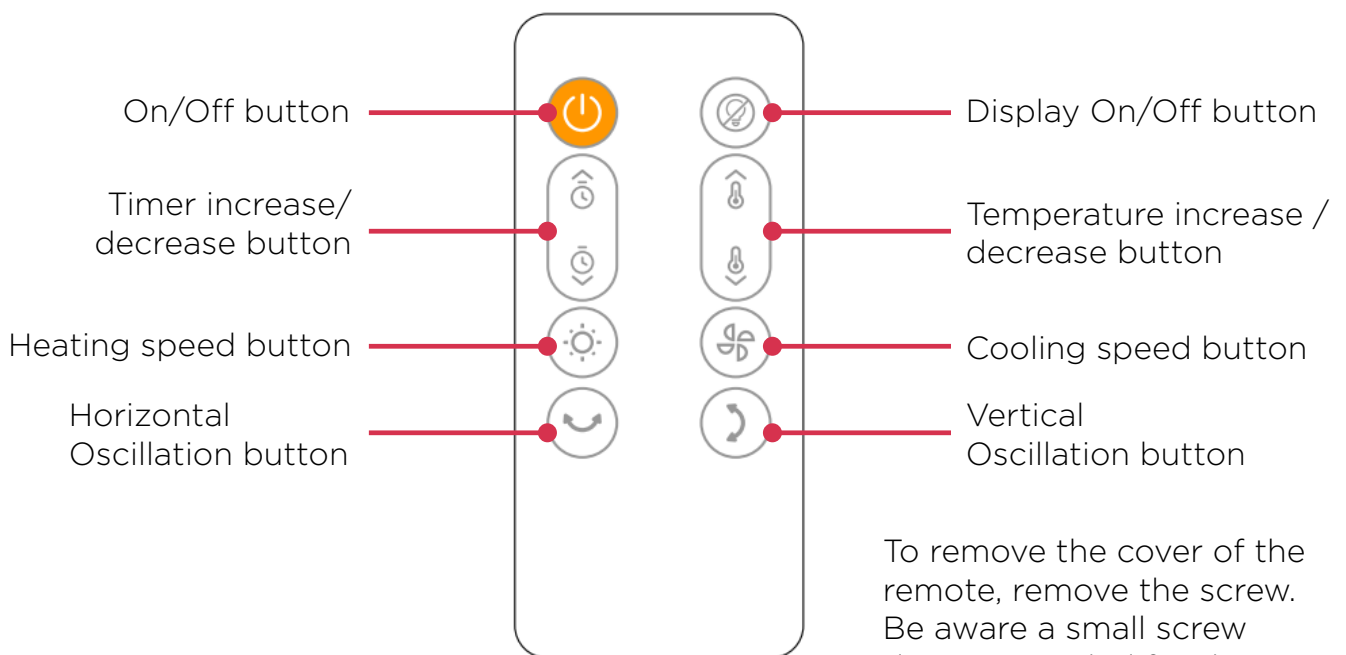

To remove the cover of the remote, remove the screw. Be aware a small screw driver is needed for this action.

IMPORTANT NOTE:

The two adjusting knobs are used to control the opening and closing of the air outlet. When adjusting, please be sure to adjust on both sides, with both hands.

When in heating mode, we recommend pulling the handles forward. This will help to reduce the entry of cold air and make the warm air feel warmer and more concentrated. See **Fig. 1** below.

When in cooling mode, we recommend pushing the handles backwards to open the air outlet. This will make the air inlet volume larger, and the noise will be significantly reduced. See **Fig. 2** below.

Fig. 1

Fig. 2

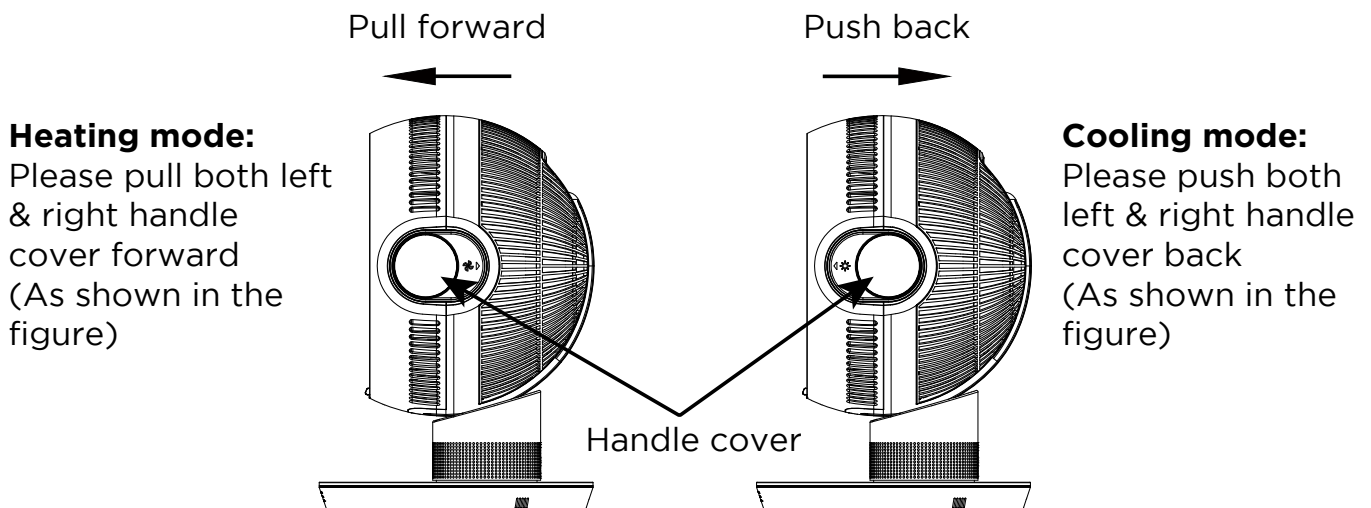

FUNCTION

After the power is turned on, the device beeps twice and enters the standby state, all functions and displays are turned off. (note: If you press the On/Off button within 10 seconds after turning off the heater or directly press the On/Off button in the heating state, the fan will delay 10 seconds before turning off. If you switch the device from heating air to cooling air and the cooling state hasn't reached 10 seconds, the fan will still delay 10 seconds before turning off. If it has entered cooling state for more than 10 seconds, all functions can be directly turned off.

ON/OFF

When in standby, only this button (1) is operational. After turning on, oscillation, timer and temperature settings are disabled and the speed indicator is always on. The default air speed is level 2, the level 2 indicator turns on, and the heating air is turned off. Press this button (1) again to enter the standby state.

COOLING AIR SPEED

When powering on for the first time, the air speed indicator light is always on, and the speed is level 2 (it starts in level 4, then switches to level 2 after 3 seconds, and only the level 2 indicator lights up). Press this button (3) to switch the speed in the following sequence: 1..2..3..4..5..1..etc. The corresponding indicator LED lights up accordingly.

TIMER SETTING

After pressing the Temp/Timer Function button (8) the timer LED light comes on and the unit enters the timer setting function. You can adjust the timer by pressing the '+' (9) or '-' (7) button to the desired working time. The adjustment does not cycle. The timer setting range is 1-12 hours and in 1 hour increments. The LED Display (11) flashes and displays the set working time. If the set working time is 0, the timer setting will be cancelled. If there is no operation of the timer button for 5 seconds or any other button, except the On/Off button (1), the device will exit the timer setting and confirm the currently set time.

TEMPERATURE SETTING

After pressing the Temp/Timer Function button (8) and the temperature LED light comes on, the unit enters the temperature setting function. You can adjust the temperature by pressing the '+' (9) or '-' (7) button to the desired temperature. The adjustment does not cycle. The temperature value can be set from 15°C to 35°C in increments of 1°C.

a) After setting the desired temperature, the unit will exit the timer setting and confirm the currently set time, if the temperature '+' (9) or '-' (7) buttons are not selected for 5 seconds or any other button, except the On/Off button (1).

b) When the ambient temperature reaches the set temperature, the heating wire turns off, the fan delays 10 seconds before turning off, oscillation stops (if it has been turned on before), and others remain unchanged. When the ambient temperature drops 2°C below the set temperature, the heating wire, fan and oscillating function (if they have been turned on before) turn on again. (For example:

If the temperature is set to 22°C, the heating wire will turn off, oscillation will stop (if it has been turned on before), and other displays remain unchanged when the ambient temperature reaches 22°C. When the ambient temperature drops to 20°C, the heating wire, fan and oscillation (if they have been turned on before) turn on again.

c) In non-ECO mode (if available), you can press the cooling air speed button (3) to exit the heating air function but the set temperature will be memorised (the LED display does not display the set temperature).

After the temperature and timer is set, the current set working temperature and remaining working time will be displayed alternately every 10 seconds.

HEATING AIR SPEED

a) The heating function is not active when the device is turned on for the first time. Press the Heating Air Speed button (4) to turn on the heating function. Press it for the first time to turn on the low-level heating air, the low-level heating indicator lights up and the low-level heating air runs at level 2 speed.

b) Press the Heating Air Speed button (4) again to turn on the high level heating air, the high level heater indicator lights up, and the high level heating wire switches on after 10 seconds (when the high level heating air is turned on, it will run at level 2 speed immediately, and the high level heating wire delays 10 seconds before switching on).

c) The ECO mode is turned on when the Heating Air Speed button (4) is pressed for the third time, and the ECO indicator light comes on. The operating rules of ECO mode are as follows:

1) The default setting temperature is 25°C and 18°C. When the ambient temperature is lower than 18°C, the heating wire runs at the high level. When the ambient temperature is equal to or greater than 18°C and lower than 25°C, the heating wire runs at the low level. When the ambient temperature is equal to or greater than 25°C, the heating wire turns off.

2) After the ECO mode is turned on, the heating wire turns off when the ambient temperature rises to 25°C, the fan turns off after a delay of 10 seconds, and oscillation stops (if it has been turned on before). Others remain unchanged, when the ambient temperature drops 2°C lower than the set temperature (that is, 23°C), the heating wire, fan and oscillation (if they have been turned on before) turn on again.

3) After the ECO mode is turned on, the heating wire turns to low level operation when the ambient temperature rises to 18°C. When the ambient temperature drops 2°C below the set temperature (that is, 16°C), the heating wire turns to high level operation. During ECO function operation, the power is high and low level, the cooling air function is not adjustable, and other functions are normal. The working cycle of the button control is: low level heating air - high level heating air - ECO mode - low level heating air..... Note: The high level and low level heating air operate at level 2 cooling air in the heating state, and the cooling air speed is not adjustable.

HORIZONTAL OSCILLATION

In the power-on state, press the Horizontal Oscillation button (5) to switch on/off the horizontal swing function, and the swing LED indicator shows its working status accordingly.

VERTICAL OSCILLATION

In the power-on state, press the Vertical Oscillation button (6) to switch on/off the vertical swing function, and the swing LED indicator shows its working status accordingly.

The operating rules of vertical oscillation are described as follows:

- a) The swing angle is 70°. When switching directions, the device first pauses for 2 seconds, and then swings to the other direction.
- b) When the device is powered on for the first time, the vertical oscillation function turns on, the motor first finds the origin [swings up 30°, pauses 9 seconds, swings down 70°, pauses 15 seconds (if the swing angle is not 30° or 70°, the motor still needs to operate for the time required for swinging 30° and 70° before proceeding to the next step). After that, the device swings up and down at an angle of 70°.
- c) Under normal shutdown conditions (press the On/Off button (1) or the timer ends), the vertical swing motor returns to the lowest point of the swing before shutting down.

SCREEN OFF

In the power-on state, press the Screen Off button (2) to enter the screen off state. The LED screen and indicator will turn off. You can press any button to restore the last display state.

OTHER

- a) Tilt protection function. If the machine tilts down, all functions are turned off and the indicator lights all turn off. It enters the standby state after recovery.
- b) Uninterruptible power memory function. If it is not the first time to turn on, press the On/Off button (1) in the standby state to turn on and keep the state before shutting down, except for the timer function.

Over time, dust can accumulate on the grille covers, filter (if applicable) and fan blades, which can affect the fans performance. It is recommended to clean the fan at least once a month.

1. Turn the unit OFF and disconnect the appliance from the power supply.
2. Remove any dust build up with a soft brush.
3. Remove the screws (four in total) on the up side and bottom side of the dust screen, then remove the dust screen on the left and right sides, and then take out the filter for cleaning.
4. Wipe the surface of the unit with a soft damp cloth. Mild detergent can be used for any stubborn marks.

IMPORTANT

The control panel and other parts must not come into contact with water or any other liquids.

Storage

If not using the unit for an extended period of time. After cleaning please:

- Turn the unit off, unplug and take care of the mains lead & plug.
- Cover the unit and store it upright in a location where it will not receive direct sunlight. NB- Prolonged exposure to direct sunlight will discolour the outer casing.

Maintenance

If the unit fails to operate efficiently, is broken or other problems arise, unplug and do not operate. Ask for advice by calling your local after sales service agent or the Customer Care Centre on 1300 556 816 (AU) / 0800 666 2824 (NZ).

Warranty

Please refer to the warranty card in the box for warranty information. For any troubleshooting advice, please contact the relative Customer Care Centre below.

Glen Dimplex Australia Pty Ltd

8 Lakeview Drive,
Scoresby 3179, Victoria
Australia
Ph: 1300 556 816

Glen Dimplex New Zealand Ltd

38 Harris Road, East Tamaki,
Auckland 2013
New Zealand
Ph: 0800 666 2824



Recycling: Do not dispose of electrical appliances as unsorted municipal waste. Use separate collection facilities. Contact your local government for information regarding the collection systems available. If electrical appliances are disposed of in landfills or dumps, hazardous substances can leak into the ground water, polluting the food chain and damaging health and well-being.



Customer Care: 1300 556 816
customer.care@glendimplex.com.au
www.dimplex.com.au

Supplied by Glen Dimplex Australia
8 Lakeview Drive, Scoresby, Victoria, 3179

© Glen Dimplex Australia. All rights reserved. Material contained in this publication may not be reproduced in whole or in part, without prior permission in writing of Glen Dimplex Australia.