



OWNER'S MANUAL

VACUUM CLEANER



Before beginning installation, read these instructions carefully. This will simplify installation and ensure that the product is installed correctly and safely. Leave these instructions near the product after installation for future reference.

ENGLISH

A9T-MAX



MFL71880919
Rev.00_011823

www.lg.com

Copyright © 2023 LG Electronics Inc. All Rights Reserved.

TABLE OF CONTENTS

This manual may contain images or content that may be different from the model you purchased.
This manual is subject to revision by the manufacturer.

SAFETY INSTRUCTIONS

READ ALL INSTRUCTIONS BEFORE USE.....3
WARNING.....3
CAUTION11

INSTALLATION

Product Overview.....13
Storing the Accessories.....17

OPERATION

Getting Started.....19
Charging the Battery.....21
Using the Steam Mop Nozzle22
Using the Nozzles and Tools.....31

SMART FUNCTIONS

Using LG ThinQ Application.....35
Smart Diagnosis Function.....37

MAINTENANCE

Cleaning the Appliance38
Cleaning the Nozzles41

TROUBLESHOOTING

Before Calling for Service.....46

SAFETY INSTRUCTIONS

READ ALL INSTRUCTIONS BEFORE USE

The following safety guidelines are intended to prevent unforeseen risks or damage from unsafe or incorrect operation of the appliance. The guidelines are separated into '**WARNING**' and '**CAUTION**' as described below.

Safety Messages



This symbol is displayed to indicate matters and operations that can cause risk. Read the part with this symbol carefully and follow the instructions in order to avoid risk.



WARNING

This indicates that the failure to follow the instructions can cause serious injury or death.



CAUTION

This indicates that the failure to follow the instructions can cause the minor injury or damage to the product.

WARNING

WARNING

- To reduce the risk of explosion, fire, death, electric shock, injury or scalding to persons when using this product, follow basic precautions, including the following:

Technical Safety

- This appliance is not intended for use by persons (including children) with reduced physical, sensory or mental capabilities, or lack of experience and knowledge, unless they have been given supervision or instruction concerning use of the appliance by a person

responsible for their safety. Children should be supervised to ensure that they do not play with the appliance.

- Do not allow the appliance to be used as a toy. Close attention is necessary when used by or near children.
- Do not allow children to play with or hang on the appliance.
- Do not use the appliance with damaged power cord or plug. The cord must be replaced. If the appliance is not working as it should, has been dropped, damaged, left outdoors, or dropped into water, return it to an LG Electronics service centre.
- Do not pull or carry by cord, use cord as a handle, close a door on cord, or pull cord around sharp edges or corners. Do not run appliance over cord. Keep cord away from heated surfaces.
- Do not unplug by pulling on cord. To unplug, grasp the plug, not the cord.
- Place the cords from other appliances out of the area to be cleaned.

Battery

- Never use the battery, adapter, and the charging station from other appliances with this appliance. Use only the battery and the charging station provided by LG Electronics.
- Never use the battery, adapter, and the charging station from this appliance with other appliances.
- Unplug the power cord and remove the battery if the appliance will not be used for an extended period of time.
- Do not use modified or damaged batteries.
- Do not disassemble, remove or short-circuit the battery.
- When disposing of the battery or the appliance, remove the battery from the appliance and safely dispose of it.
- Have specifically designated battery packs replaced when it is no longer able to hold a charge.
- Refer to the **Charging the Battery** section instructions for the method of replacing the battery.

- When disposing of this appliance, follow regulations for disposal of rechargeable lithium-ion batteries.
- Follow all local ordinances and regulations when handling or disposing of the battery.
- Prevent unintentional starting. Ensure the switch is in the off position before connecting to the battery pack, picking up or carrying the appliance.
- Disconnect the battery pack from the appliance before making any adjustments, changing accessories, cleaning, serving, or storing appliance.
- When battery pack is not in use, keep it away from other metal objects, like paper clips, coins, keys, nails, screws or other small metal objects, that can make a connection from one terminal to another.
- Under abusive conditions, liquid may be ejected from the battery. If this happens, avoid contact. If contact accidentally occurs, flush with water. If liquid contacts eyes, additionally seek medical help.
- If the appliance is to be stored unused for a long period, the batteries should be removed.
- Before removing the battery, you must turn off this appliance.
- When fitting the battery into the product body, insert it completely until it clicks.

Battery Specifications

- One or two batteries are provided, the number of batteries varies depending on the model purchased.
 - **Model Name:** EAC633822** or EAC637586**
 - **Type:** Rechargeable Lithium-ion Battery
 - **Rated Capacity:** 2400 mAh

Installation

- To avoid an electrical shock or fire, do not install, charge or store the appliance where it may be exposed to water, rainfall or high humidity.

- Install, charge and store the appliance in a well-ventilated place.
- Avoid operating the appliance in areas where there is a risk of leakage of flammable gas, industrial oil or metallic dust.
- Do not store or install the appliance, power cord or plug near heating devices or open flames.
- Install the charging station on a firm, level surface.
- Do not use or store the appliance at temperatures below 5 °C or above 38 °C.
- Do not store or install the appliance where it is exposed to temperatures below freezing or exposed to outdoor weather conditions.
- When installing or moving the appliance, be careful not to pinch, crush, or damage the power cord or plug.

Operation

- Read all instructions before using the appliance, and save these instructions.
- Use only as described in this manual. Use only manufacturer's recommended attachment.
- This appliance is designed for normal indoor domestic use only. It is not to be used for any non-residential, commercial, or industrial application.
- Do not handle the power cord, plug, or appliance controls with wet hands.
- Wipe any moisture or dirt off the cord or plug with a dry cloth.
- Never attempt to operate this appliance if it is damaged, malfunctioning, partially disassembled, or has missing or broken parts, including a damaged cord or plug. Take it to an authorized LG Electronics service centre or dealer for assistance.
- Do not apply excessive force to the power cord to bend it, or place it under a heavy object as this will damage it.
- Do not use multiple-outlet adapters with this appliance. Make sure to use a power socket with a capacity of 10 A.

- Do not plug the appliance into a damaged or loose outlet.
- Make sure to unplug the power cord when the appliance is not to be used for an extended period of time.
- Do not damage, alter, excessively bend, twist, pull, pinch or heat the power cord.
- Before using the appliance, remove any wire or string on the floor.
- Avoid touching the prongs of the power plug with your finger(s) when unplugging the power cord.
- Do not cover the power cord with a rug or carpeting.
- Push the power plug firmly into the wall outlet so that it is not loose.
- If the product has been submerged, contact an LG Electronics service centre or dealer for instructions before resuming use.
- If the product makes a strange noise or emits an odour or smoke, discontinue use and contact an LG Electronics customer information centre.
- Only qualified technicians or service personnel from LG Electronics may disassemble, repair or modify the appliance.
- Never insert a sharp metallic object such as a pin, nail or knife in a hole or gap in the appliance or the charging station.
- Do not vacuum liquids with this appliance. Make sure that no water, beverage or detergent gets inside the appliance or the charging station.
- Do not allow the appliance to sweep up blades, thumb tacks, sawdust, sharp objects, or hot or cold ashes.
- Do not allow children to use the appliance.
- Do not let children or pets get close to the appliance when using, charging or storing.
- Do not insert the nozzle or tools in your mouth.
- Keep clothing and hair, fingers, or other parts of the body away from openings and moving parts.
- Do not operate the appliance with the suction inlet or outlet blocked.
- Do not use the appliance without the dust bin and filters in place.

- Do not use in an enclosed space where vapors are present from paint thinner, mothproofing substances, flammable dust or other explosive or toxic materials.
- Do not touch the charging terminals on the appliance or the charging station, or insert an electrified object inside the appliance or the station.
- Always store the appliance on the charging station when it is not in use.
- Do not lean the appliance on walls, chairs or tables.
- If the earth leakage breaker is tripped when the product is put on the charging station, immediately remove the appliance from the charging station. Contact an LG Electronics customer service centre.
- Use extra care when cleaning on stairs.
- Do not use or store a heating device or flammable substance(ether, benzene, alcohol, chemicals, combustible sprays, insecticide, air freshener or cosmetics) in close proximity to the appliance.
- Do not attempt to clean up a liquid substance (water, beverage), odourous substances (candy, chocolate, pet excrement), metallic objects (blades, pins), flammable substances, burning/ smoking(cigarettes, matches, or hot ashes), surfactants, or glass shards with this appliance.
- In the event of a gas leak(natural gas, propane gas, etc.), do not operate this or any other appliance. Open a window or door to ventilate the area immediately.
- Do not hold the charging station upside down with the battery in the charging station.
- Do not expose the appliance, and the battery in particular, to heat, a heating device or direct sunlight.
- Do not keep the appliance or its battery inside a vehicle which is exposed to direct sunlight.
- Never allow any water, beverage or detergent to get inside the battery.
- Do not apply physical impacts to the battery.

Maintenance

- Make sure to unplug the power cord when cleaning or maintaining the charging station.
- Do not wash the inlet port or the dust bin with water or detergent.
- Do not use detergents, polishes or air fresheners to clean the dust bin.
- Do not apply or spray a flammable substance (gasoline or thinner) or surfactants (detergent or bath soap) on the appliance.
- Wash hands after handling nozzles. The nozzles contain carbon fiber, and contact may cause minor skin irritation.

Disposal

- Keep packing materials out of the reach of children. Packaging materials can pose a suffocation risk for children.
- Destroy the carton, plastic bag, and other packing materials after the appliance is unpacked. Children might use them for play. Cartons covered with rugs, bedspreads, or plastic sheets can become airtight chambers.
- Dispose of this appliance according to local, state, and regional laws and regulations.
- Contact your local city council or the related government authority before disposing of this appliance.

Steam Mop Nozzle

- Keep the appliance out of reach of children when it is energized or cooling down.
- Push the battery all the way into the battery pocket. Otherwise the steam mop nozzle may not operate normally or the battery may fall to the floor.
- Do not vacuum sharp objects (glass pieces, wire, blades, pins, etc.) with the mop nozzle attached. When cleaning the mop pads after mopping, you could be injured by a sharp object embedded in the mop.

- Do not insert your fingers into the steam mop nozzle while it is working.
- Do not separate the water tank from the steam mop nozzle or add water to the water tank while the power is on or cleaning in progress. Doing so may result in burns due to steam or hot water.
- Never turn the steam mop nozzle upside down, tilt or shake it while the power is on, while cleaning, or immediately after cleaning is finished. Steam or hot water may leak and cause burns.
- While the power is on, do not turn the steam mop nozzle upside down to attach the mop pads. Doing so may cause hot water to leak, resulting in burns.
- Do not point the steam mop nozzle at people or animals. Doing so may result in burns due to steam.
- Do not use the steam mop nozzle on glass. Doing so may break the glass, resulting in injury.
- Do not use steam to clean electronics, such as ovens. Doing so may break or damage the electronics.
- Be careful not to get your fingers caught in the bends around the nozzle hose.
- Wet floors can pose a slip hazard. Allow floors to dry completely before allowing anyone to walk on them.
- After steam cleaning, hot steam may become water droplets and hot water may flow from the inlet. After cooling the product sufficiently, clean the nozzle and store the product in the charging station.
- After cleaning, separate the mop pads from the steam mop nozzle after letting it cool sufficiently. Touching the steam mop nozzle or the mop pads before they are sufficiently cooled may result in burns.
- Separate the battery from the battery pocket when attaching the water tank to the steam mop nozzle or attaching the mop pads.
- After using the steam mop nozzle, be sure to separate the battery from the battery pocket
 - before cleaning or storing the steam mop nozzle, etc.



Warning : Steam. Risk of burns.

- The pressure of generated steam is less than 50 kPa.

CAUTION

CAUTION

- To reduce the risk of injury to persons, malfunction, or damage to the product or property when using the appliance, follow basic safety precautions, including the following:

Operation

- This appliance has a built-in safety device to prevent damage from overheating. If the appliance becomes overheated after extended use, it may automatically turn off. If this occurs, leave the appliance in a cool, well-ventilated area for about an hour before turning on the power again.
- Do not subject the product to shocks or drop it.
- Do not install wet or damp filters.
- Always use a soft cloth to clean the appliance. Do not clean the product with a volatile or organic solvent (thinner or acetone).
- Do not clean the same spot repeatedly for an extended period of time. Doing so may damage the carpet or flooring surface.
- Keep fingers away from pinch points when assembling the appliance or the charging station.
- Do not apply force or any impact to the Cyclonic Mesh Filter.
- Do not remove the battery during operation.

Steam Mop Nozzle

- Do not use the steam mop nozzle for any purpose (for example, polishing a car, cleaning windows) other than domestic floor cleaning.
- Do not use the steam mop nozzle to vacuum up liquids (water, beverage).
- When using the steam mop nozzle, always attach the mop pads.
- Do not clean a coated, rough or delicate floating floor and carpets with the steam mop nozzle.
- Do not use the steam mop nozzle to clean the same spot repeatedly for an extended period of time. The water injection at the steam mop nozzle may cause water to get into the dust inlet and damage the appliance.
- Do not step on the steam mop nozzle.
- Do not store the appliance by attaching the water tank filled with water to the steam mop nozzle.
- Do not leave the steam mop nozzle in the one place with the power turned on, and do not clean the same area repeatedly for a long time. Doing so may discolour or deform the floor due to hot steam.
- Do not put disinfectant into the water tank for sterilization or deodorization purposes. Doing so may cause product failure or damage, and may discolour the wet mop.
- Do not put hot water, detergent, disinfectant, deodorant, fabric softener, or aromatic oil in the tank. Use nothing other than room temperature water in the water tank for cleaning.
- Do not repeatedly clean coated floors. Doing so may cause the coating to peel off.
- Do not use on PVC or PU mat for infants or children. Doing so may damage the mat or cause the mop attachment plate to not rotate smoothly due to hot steam, and the motor may overheat.
- Put purified water in the water tank.
- When carrying the vacuum cleaner with the extension pipe and the steam mop nozzle attached, hold the extension pipe and the product body with both hands so as not to drop it.

INSTALLATION

Product Overview

The images in this guide may be different from the actual components and accessories, which are subject to change by the manufacturer without prior notice for product improvement purposes.

Front View

*1 This feature is only available on some models.

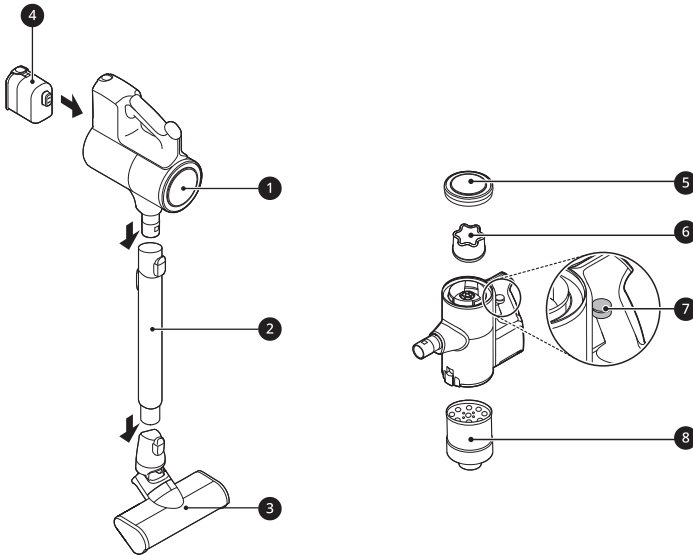

- ❶ Product Body
- ❷ Extension Pipe
- ❸ Nozzle
- ❹ Battery (Dual Battery*1)
- ❺ Exhaust Filter
- ❻ Pre-filter
- ❼ Kompressor Lever
- ❽ Cyclonic Mesh Filter

14 INSTALLATION

NOTE

- Use the vacuum cleaner only with the provided charging station. Using a charging station other than the one designed to be used with the vacuum cleaner, as improper sealing of the charging station may result and dust not being emptied from vacuum cleaner.
-

Accessories

*1 This accessory is only available on some models.

Included Accessories

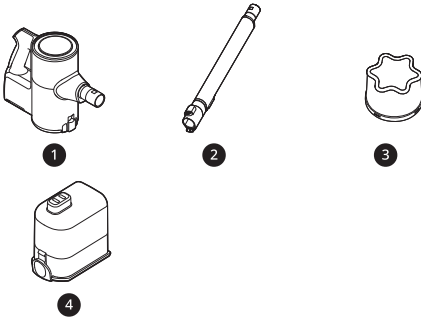

- ① Product Body
- ② Extension Pipe
- ③ Pre-filter
- ④ Battery (Dual Battery)*1

Basic Accessories

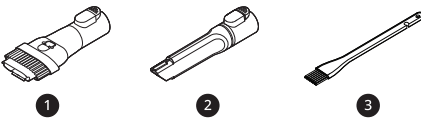

- ① Combination Tool
- ② Crevice Tool
- ③ Cleaning Brush

Nozzles

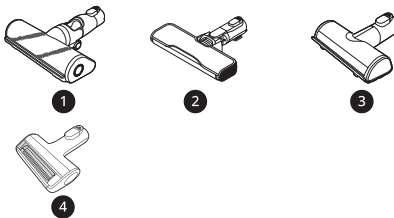

- ① Multi-Surface Nozzle*1
- ② Wide Hard Floor Nozzle*1
- ③ Bedding Nozzle*1

- ④ Pet Nozzle*1

Tools

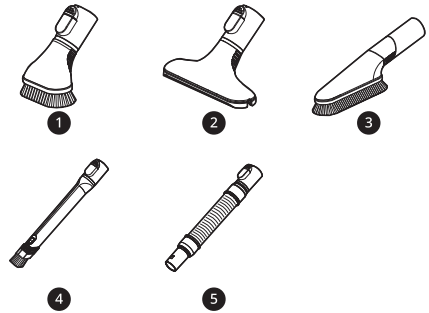

- ① Hard Dirt Tool*1
- ② Mattress Tool*1
- ③ Multi-angle Tool*1
- ④ Flexible Crevice Tool*1
- ⑤ Flexible Hose Extension*1

Mop Kit

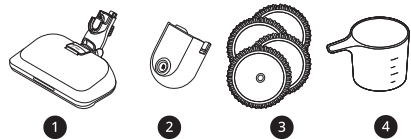

- ① Steam Mop Nozzle*1
- ② Battery Pocket for Steam Mop Nozzle*1
- ③ Mop Pads for Steam Mop Nozzle*1
- ④ Measuring Cup*1

NOTE

- The mop pads, batteries, exhaust filter and the pre-filter will eventually need to be replaced. Contact an LG Electronics customer service centre.
- Batteries are not included in the battery pocket.

Specifications

Appliance

Model	A9T-MAX		
Dimensions (Width X Depth X Height)	260 mm X 270 mm x 1120 mm		
Weight	Approximately 2.6 kg		
Power Consumption	370 W in Turbo Mode (Maximum 590 W) 120 W in Power Mode 68 W in Normal Mode		
Battery Run Time (Using two battery)	Using with the Nozzle*1 Up to 12 minutes in Turbo Mode Up to 40 minutes in Power Mode Up to 80 minutes in Normal Mode	Using with the Tool Up to 14 minutes in Turbo Mode Up to 60 minutes in Power Mode Up to 120 minutes in Normal Mode	Using with the Steam Mop Nozzle (One battery for the vacuum cleaner, another for the steam mop nozzle) Up to 10 minutes in Steam Mode
Battery Run Time (Using one battery)	Using with the Nozzle*1 Up to 6 minutes in Turbo Mode Up to 20 minutes in Power Mode Up to 40 minutes in Normal Mode	Using with the Tool Up to 7 minutes in Turbo Mode Up to 30 minutes in Power Mode Up to 60 minutes in Normal Mode	

- Dimensions are given for the assembled product body, extension pipe and nozzle.
- Suction power is an average of suction power with IEC 62885-2, 5.8 standard tested by an independent test lab. Individually measured data would be different from a lab test result.
- Battery run time is the result of using a fully charged battery according to the LG Electronics test standard. Results may be different depending on actual use environment and period of use.

*1 The Nozzle contains the direct drive motor that rotates the nozzle cleaning head directly.

Charging Station

Model	VDS-ST2GU
Input	220 - 240 V~ 50 Hz
Output	28.3 V=== 1.15 A
Power Consumption	1700 W (Cleaning) 0.4 A (Charging)

Storing the Accessories

Assembling and Storing the Appliance

Follow these steps to safely assemble the appliance.

- 1 Firmly attach the extension pipe **3**, nozzle **4**, or tool onto the product body **1**.
 - To detach the extension pipe, press the extension pipe release button **2**.

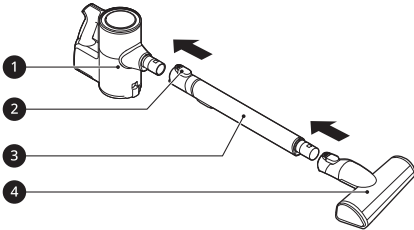

- 2 Put the product body on the charging station.
 - If the vacuum cleaner fits properly inside the product, the alarm will sound. If the alarm does not sound, reinsert the vacuum cleaner.

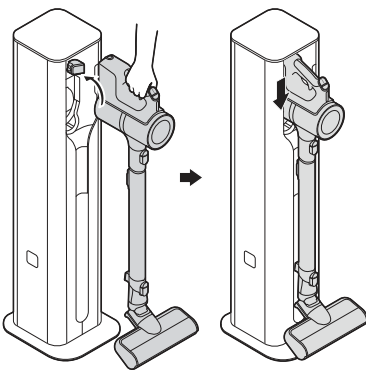

Storing on Sides

- 1 Open the nozzle hook **1** on both sides of the product.
 - To open the nozzle hooks, press on the right side. Be careful not to pinch fingers when opening.

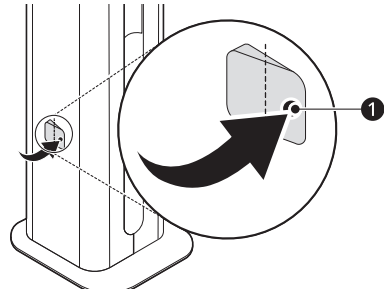

- 2 Hang the nozzle on the nozzle hook.
 - When storing the steam mop nozzle, store it after removing the battery from the battery pocket.

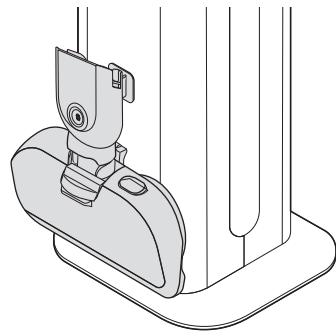

Storing the Tools

Use the product to store the inlet and components provided with the vacuum cleaner.

The components may differ depending on the vacuum cleaner model.

Storage Inside

- 1 Open the left door of the product and insert the bedding nozzle or the pet nozzle **1** for storage.

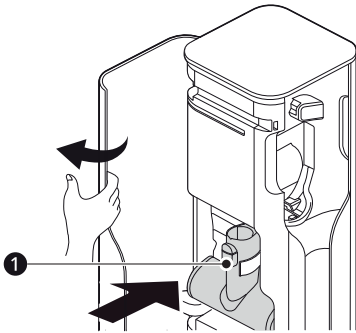

- Before moving the product, unplug it and remove the vacuum cleaner, nozzles, and accessories.

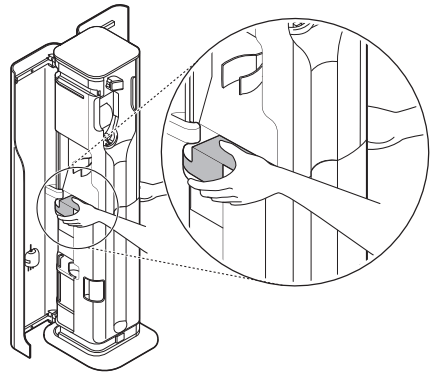

- 2 Open the right door and insert the combination tool **2**, the crevice tool **3** and the cleaning brush **4** for storage.

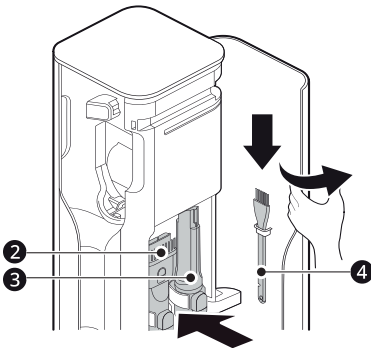

Moving the Product

To carry the product, open both doors and hold the areas shown.

OPERATION

Getting Started

Before Using the Appliance

- Support the bottom of the appliance when cleaning an elevated surface.
- To avoid scratches on polished floors, keep tools and the brushes and rollers of the nozzles free from hair, grit, sand, or abrasive objects.
- Make sure that the exhaust filter or pre-filter is properly assembled before using the appliance.
- Close the dust bin cover properly before using the appliance. If the dust bin cover is left open, the suction strength may deteriorate and affect the cleaning results.
- Store the appliance in the charging station or place it flat on the floor when not in use. Leaning the appliance against a wall or chair can result in product damage or personal injury if the appliance falls.
- Environmental conditions such as temperature and humidity may cause static electricity to accumulate on the appliance. Please contact LG Electronics customer information centre if the problem persists.
- Make sure to remove any foreign object such as a sock or stocking before using the appliance. Any foreign object on the inlet port or extension pipe will prevent the appliance from functioning properly.
- Please use the product at normal room temperatures as the battery runtime may deteriorate severely if used at temperatures lower than 5 °C or higher than 38 °C for an extended period of time.
- The battery runtime is dependent on the surface type and the suction power.
- Follow manufacturer's recommendations when cleaning flooring, carpets, and rugs.
- Refer to the **Specifications** section for battery runtime details.

Assembling Attachments

Nozzles and tools can be attached to either the product body or the end of the extension pipe.

- 1 Insert the fully charged battery ❶ into the cavity at the bottom of the handle on the product body and push the battery until it clicks.
 - If it is not properly inserted, the battery may fall out, causing product to malfunction or personal injury.

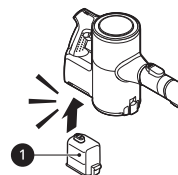

- 2 Attach the nozzles, tools, or extension pipe by sliding them onto the inlet ❷ on the body until they click into place. The nozzles and tools can also be attached to the end of the extension pipe ❷.
 - Detach the accessories by pressing the release button ❸.

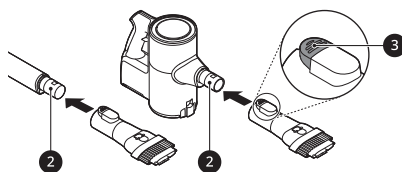

- 3 Adjust the extension pipe by pressing the length adjustment button ❹ on the back of the pipe and sliding until it clicks into place at the desired length.

20 OPERATION

- The extension pipe extends in four steps.

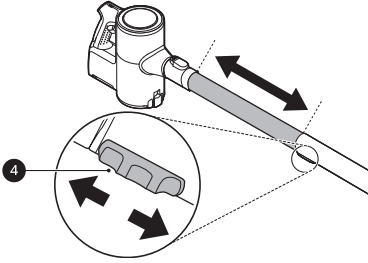

4 Press the **Power** button to activate the **Normal** mode.

- To turn off the appliance, press the **Power** button again.

Adjusting the Suction Power

Adjust the suction power using the suction power adjustment button on the handle.

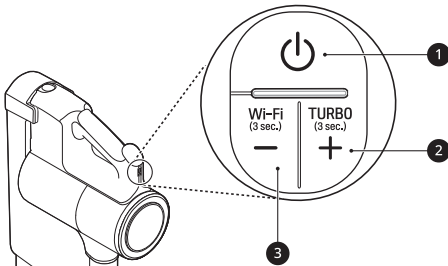

1 Power Button

- Press the **Power** button to turn the appliance on or off.
- Press the **Power** button to activate **Normal** mode.

2 Suction Power Up (+) Button / Turbo Mode

- Press the + button to increase the suction power. (**Normal**→**Power**)
- Press and hold the + button for more than 3 seconds to activate **Turbo** mode from **Normal** and **Power** mode.

3 Suction Power Down (-) Button / Wi-Fi Mode

- Press the - button to decrease the suction power. (**Turbo**→**Power**→**Normal**)

- Press and hold the - button for 3 seconds to activate Wi-Fi and connect the appliance in the **LG ThinQ** application.

Display

The handle of the appliance displays indicators for clogged objects, filter cleaning alerts, appliance connection status, and the remaining battery charge.

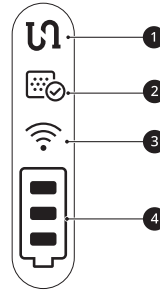

1 Clogged Objects Indicator

- This indicator lights up when the interior of the product body, extension pipe, inlets, nozzle, exhaust filter, pre-filter, or cyclonic mesh filter is clogged with foreign objects.
- If clogging persists, the motor will cycle and the appliance will shut off. Remove the foreign objects and clean the exhaust filter, pre-filter and cyclonic mesh filter following the steps in the Removing Foreign Objects section.

2 Filter Cleaning Cycle Alarm Indicator

- This indicator lights up when the appliance is used for a certain period of time. Clean the exhaust filter, pre-filter and cyclonic mesh filter if necessary.

3 Wi-Fi Indicator

- This indicator blinks when the appliance is connecting to the **LG ThinQ** application or home Wi-Fi network, and the indicator lights up when the connection is complete.

4 Battery Level Indicator

- The remaining battery level is displayed in 3 stages according to the remaining battery power.
- The battery level indicator blinks when the battery needs to be charged.

- As the product is charging, bars light up on the battery level indicator to indicate the level of charge.
- Once the battery is fully recharged, 3 bars will remain lighted on the battery level indicator.

Charging the Battery

Before Charging the Battery

- Make sure that the adapter is connected to both the charging station and the power outlet.
- Fully charging a single battery usually takes 4 hours. It will take twice as long to charge both the main and spare batteries.
- The battery will not be charged if the indoor temperature is below 5 °C. Only charge the battery when indoor temperatures are between 5 °C and 38 °C.
- The battery will eventually need to be replaced. Due to the battery characteristics, runtime is shortened after using the appliance repeatedly for an extended period.
- The last bar on the battery indicator begins to flash when the battery needs to be recharged. Use the appliance with a fully charged battery.
- To maintain battery life on dual-battery models, swap the positions of the two batteries periodically, between the main body and the spare charging station.

Charging the Vacuum Cleaner

Storing the appliance on the charging station automatically recharges the battery.

- 1 Press the **Power** button to turn the appliance off.
- 2 Put the product body on the charging station.
 - Make the extension pipe its shortest length before placing the vacuum onto the charger.
 - The appliance cannot be loaded onto the charging station if either the combination tool or the crevice tool is inserted. Use the charging station only after removing the

combination tool or the crevice tool, if either happens to be fitted

- If you don't hear a beep, reload the appliance on the charging station.
- Once the battery is fully recharged, 3 bars will remain lit on the battery level indicator.

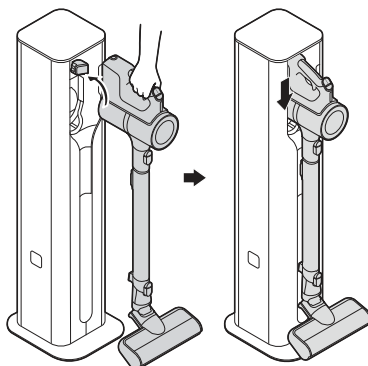

⚠ WARNING

- Make sure to securely fit the product body onto the charging station. If the appliance falls off the charging station, it could cause injuries, property damage or product damage.

Charging the Spare Battery

After the vacuum cleaner has finished charging, the spare battery will start charging.

One or two batteries are provided. The number of batteries varies depending on the model purchased.

- 1 Lift the front of the control panel located at the top of the charging station.

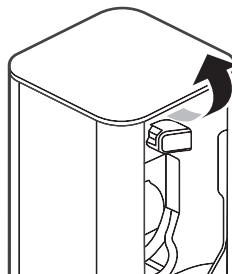

- 2** To insert, align the battery with the outline of the battery charger.

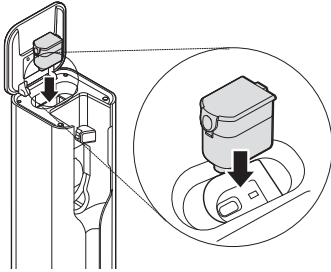

- 3** Press the battery down into the compartment.

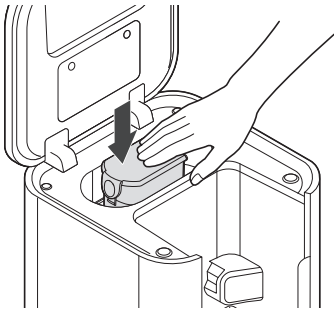

NOTE

- The spare battery icon (🔋) in the status display flashes during charging and remains on when charging is complete.
- Insert the spare battery completely. If the spare battery is inserted correctly, the spare battery icon (🔋) flashes.
- The battery pocket does not have a charging function. Separate the battery from the battery pocket and charge it using the charging station.

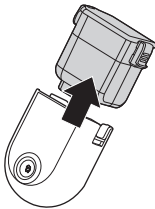

Using the Steam Mop Nozzle













Before Using the Steam Mop Nozzle





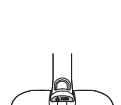









- The mop pads only rotate at one speed regardless of what suction power setting the product body is set to.
- To prevent product damage, the mop attachment plate will automatically stop if there are foreign objects stuck in the plate or if it is subjected to a strong impact. Turn the appliance off immediately and remove the foreign objects or obstructions before resuming use.
- If you use **only mop mode** for a long time with the suction off, the motor may overheat (recommended duration of use: 80 minutes). When the motor overheats, the overheating prevention function is activated and the appliance is automatically turned off. Use the appliance after cooling the heat for about one hour in a cool, well-ventilated place.
- When using the steam mode with a fully charged battery in the battery pocket, it is recommended to replace only two batteries if the batteries are discharged and need to be replaced. If you use the steam mode for a long time, the motor may overheat and the product may turn off.
- If you hear a noise while mopping, the mop pad may have dropped off the mop attachment plate. Turn off the product immediately and reattach the mop to the attachment plate before resuming use.
- If the suction function is used together with steam or wet mop cleaning, wet dust may be inhaled and the product may smell. In dusty areas, clean with the suction function before cleaning with the steam or mop function.
- Do not use a soiled mop pad to clean floors.
- Clean only with the mop pads for the steam mop nozzle provided when purchasing from LG Electronics. The mop pads from other products may reduce cleaning performance.
- When cleaning in the normal mop mode, if the water adjustment buttons of the steam mop nozzle touch the legs of a chair or table and are pressed, the amount of water may change or the water supply may be turned off.

- Empty the dust bin and clean the exhaust filter and the pre-filter after using the mop nozzle.
- When using the steam mode, the warmth of the floor may be felt differently depending on the surrounding environment (temperature, season, material of the floor). It's also normal for no steam to be emitted from the mop pads as it can be diffused by the floor or by the wet mop pads.

Alarm and LED by Steam Mop Nozzle Condition

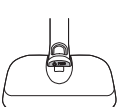
When using the steam mop nozzle, check the operation status through the alarm and LED for each condition.

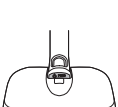
Nozzle Front LED	Battery Pocket LED	Condition	Alarm and LED by Condition
 Off	 Off	Vacuum cleaner power off	The nozzle front LED of the steam mop nozzle is on and the battery pocket LED turns off.
 On	 Off	Operating normal mop mode	The nozzle front LED of the steam mop nozzle is on and the battery pocket LED turns off.
 Blinking	 On	Preheating in the steam mode is in progress.	The nozzle front LED blinks with the preheating start alarm and the battery pocket LED is on.
 On	 On	Preheating is completed and steam operation is in progress.	With the preheating completion alarm, the nozzle front LED and the battery pocket LED are on.
 On	 Blinking	The steam mode is in use. There is no water in the water tank.	An alarm will briefly chime and the battery pocket red LED will flash continuously for one minute before the steam mop nozzle turns off. <ul style="list-style-type: none"> When using the normal mop mode, the battery pocket LED does not blink even if there is no water in the water tank.
 On	 Blinking	The steam mode is in use. Low battery in the battery pocket	An alarm will briefly chime and the red LED on the battery pocket will continue to flash until the battery is flat. The red LED on the battery pocket will then turn off and the steam mode will no longer be working but the normal mop mode will continue to operate.

Nozzle Front LED	Battery Pocket LED	Condition	Alarm and LED by Condition
 On	 Off	The steam mode is in use. Discharged battery in the battery pocket	The nozzle front LED is on and the battery pocket LED turns off. <ul style="list-style-type: none"> The steam mode will no longer operate but the mop pads will continue to rotate.
 On	 Off	The steam mode is activated without attaching the mop pads.	The nozzle front LED is on and the battery pocket LED turns on and off immediately.
 On	 Off	The steam mode is in use. The nozzle is tilted or lifted off.	The nozzle front LED is on and the battery pocket LED turns off.
 On	 Off	The steam mode is in use. The nozzle has not moved for approximately 20 seconds.	The nozzle front LED is on and the battery pocket LED turns off.
 Off	 Off	The steam mode is in use. The nozzle has not moved for approximately 1 minute.	The nozzle front LED and the battery pocket LED turn off.
 Off	 Off	The steam mode is in use. The mop attachment plate stops spinning.	The nozzle front LED and battery pocket LED turn off.
 On	 Blinking rapidly	It malfunctions.	With the alarm, the battery pocket LED blinks rapidly

Using the Steam Mop Nozzle

Press the **Power** button. You can use the only mop mode and not turn on the dust suction function.

By default, the dust suction function will be on in normal mop mode or steam mode.

- Press the **+** button to turn on the dust suction function.

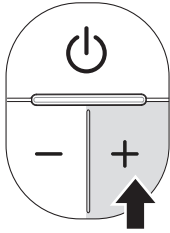

- Press the **-** button once while pressing the **+** button once to turn off the dust suction function.

Steam mode	<ul style="list-style-type: none"> • Insert the battery pocket and onto the battery into the steam mop nozzle and turn on the power to the main unit.
Normal mop mode	<ul style="list-style-type: none"> • Turn on the power to the main unit without inserting the battery pocket or the battery into the steam mop nozzle.
When switching from steam mode to normal mop mode	<ul style="list-style-type: none"> • While using in steam mode, press the steam button in the battery pocket to turn off steam mode. • The battery in the battery pocket will only be used when the steam mode operation is on.

extended period of time. Failure to do so may result in product failure.

- Do not use on PVC or PU mats for infants or children. Hot steam may damage the mat or cause the mop attachment plate to not rotate smoothly, resulting in overheating the motor.
- Do not force the steam mop nozzle onto the floor or apply any force to it. Doing so may damage the floor and/or the product.
- Do not step on the steam mop nozzle. Doing so may damage the product.

Filling the Water Tank

- 1 Press the **PUSH** button **1** to remove the water tank from the mop nozzle.

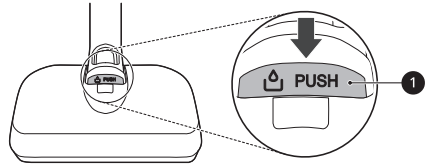

- 2 Open the water inlet cap **2** on the side of the water tank and fill the tank with water using the measuring cup **3**.

- Do not put any liquid other than purified water and hot water in the water tank.
- After filling the water tank with water, wipe any remaining water from the surface of the water tank to prevent any remaining from falling onto the floor.

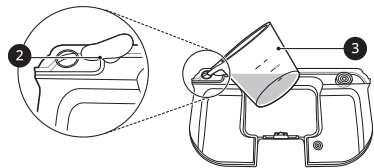

- 3 Close the water inlet cap tightly.

⚠ CAUTION

- Do not assemble or disassemble the nozzle while the appliance is turned on. Doing so may result in injury.
- Set the water adjustment button to the **STOP** position when not using the appliance for an

- If the water inlet cap is not closed properly, water may leak.

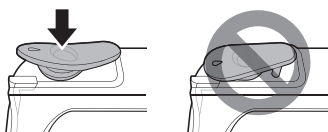

4 Attach the water tank to the mop nozzle again.

- Insert the 2 tabs **4** at the front of the water tank into the slots **5** on the top of the mop nozzle. Press down at the centre **6** to lock the tank in place.

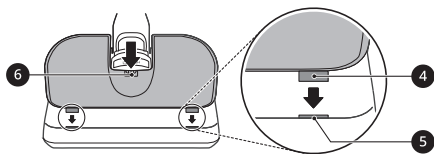

⚠ WARNING

- Be sure to attach the mop pads after turning off the power. Failure to do so may cause the mop attachment plate to rotate and may result in injury.

⚠ CAUTION

- Do not let the appliance stand on the floor while the wet mop pads are attached. Doing so may result in damage or swelling to wood flooring.

Attaching the Mop Pads

- 1 Wet both sides of the mop pads with water then squeeze out any excess water before attaching the pads.

- Do not attach pads while they are dripping wet.

- Use wet mop pads instead of dry mop pads when using steam mode

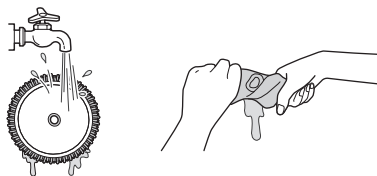

2 Place the mop nozzle upside down on the floor.

3 Align and attach the centre of the mop pad with the centre of the mop attachment plate.

- Attach the Velcro on the mop pad to the mop plate. Attaching the mop pad upside down or improperly may affect the cleaning results.

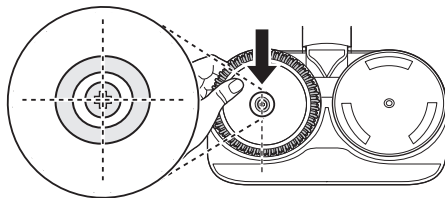

4 Attach the mop nozzle to the appliance.

⚠ WARNING

- To avoid injury, do not attach the mop pad while the mop attachment plate is rotating.

⚠ CAUTION

- Do not let the appliance stand on the floor while the wet mop pads are attached. Doing so may result in damage or swelling to wood flooring.

Using Normal Mop Mode

Press the water adjustment buttons to adjust the amount of water released onto the mop pad to either **High Mode** or **Low Mode**.

28 OPERATION

When using the steam mode, a constant amount of water is supplied regardless of the operation of the water adjustment buttons.

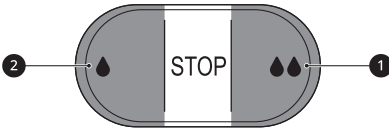

- **High Mode:** Press the **High Mode** button **1** all the way down to clean ingrained dirt or supply a large amount of water.
- **Low Mode:** Press the **Low Mode** button **2** all the way down to supply a small amount of water for cleaning wood or other flooring that can be damaged by too much water.
- **STOP:** Press the **Low Mode** or **High Mode** button halfway to toggle back to the **STOP** position. This stops the supply of water so you can go over areas that are already wet.

Using with the Steam Mop Nozzle

- When using the steam mode, a constant amount of water is supplied regardless of the operation of the water adjustment buttons.
- Insert the water tank filled with water into the steam mop nozzle, attach the mop pads soaked in water, and then insert the battery pocket.

- 1** Insert the battery pocket **2** into the steam mop nozzle **3**, and insert the fully charged spare battery **1** into the battery pocket **2**. Push the battery pocket and the battery all the way in until a click is heard.

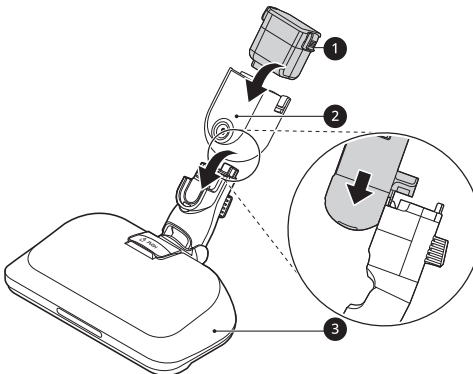

- 2** Insert the steam mop nozzle into the extension pipe and connect it to the product body. When you press the **Power** button **4** on the product body, the steam mode will be turned on and preheating will begin.

- During preheating, the nozzle front LED will blink.
- When you turn on steam mode, the steam generator will be preheated for about 40 seconds and then steam will be sprayed. Begin cleaning when the red battery pocket LED turns on. It's normal for steam to not be emitted from the mop pads as the steam can be dissipated by the floor or the pads.
- After steam is sprayed, it takes about 80 seconds for the mop pads to be heated to about 60 °C.

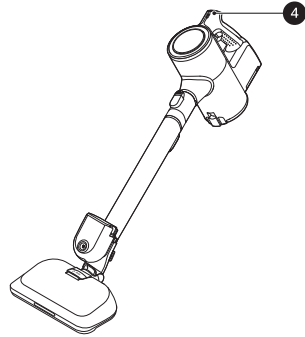

Charging the Battery and Storing the Steam Mop Nozzle

- 1** When cleaning is finished, press the **Power** button on the product body to turn the product off.
- 2** The battery pocket does not have a charging function. Separate the battery from the battery pocket.

pocket and charge it using the charging station.

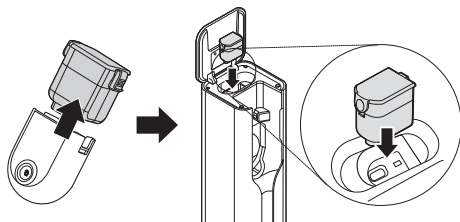

- 3** Press the release button and separate the extension pipe.

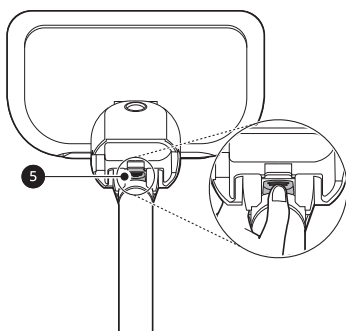

- 4** Hang the nozzle on the nozzle hook.

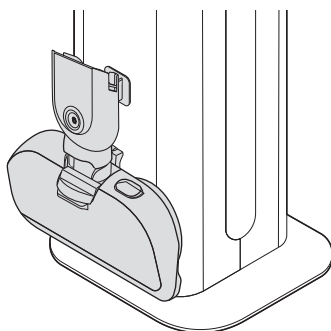

Separating the Battery Pocket

Separate the battery pocket by pressing the PUSH button on the bottom of the battery pocket and sliding it upward off the mop nozzle.

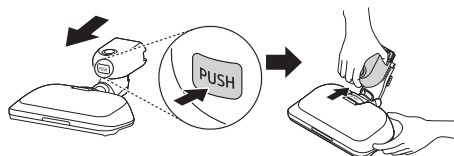

⚠ WARNING

- Do not separate the water tank from the steam mop nozzle or add water to the water tank while the power is on or cleaning in progress. Doing so may result in burns due to steam or hot water.
- Never turn the steam mop nozzle upside down, tilt or shake it while the power is on, while cleaning, or immediately after cleaning is finished. Steam or hot water may leak and cause burns.
- After cleaning, separate the mop pads from the steam mop nozzle after letting it cool sufficiently. Touching the steam mop nozzle or the mop pads before they are sufficiently cooled may result in burns.
- After steam cleaning, hot steam may become water droplets and hot water may flow from the inlet. After cooling the product sufficiently, clean the nozzle and store the product in the charging station.

NOTE

- If there is no water in the water tank, no steam will be produced. Fill the water tank with water and attach the pre wet mop pads before use.
- When the steam mop nozzle is turned on and left in place, no steam will come out in order to prevent damage to the floor.

NOTE

- When cleaning with steam, press the steam button ❶ to turn off the steam mode and use the product in normal mop mode.

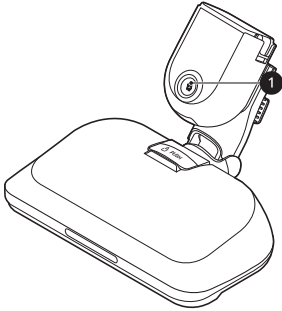

- The steam cools and can condense into water droplets, which can drip when the nozzle is turned upside down or stored. This is not a leak, so use it with confidence.

Drying the Water Tank and Mop Pads

Drying the Water Tank

When cleaning is completed, make sure to empty the water tank and allow it to dry before storing the steam mop nozzle.

⚠ WARNING

- After cleaning, separate the mop pads from the steam mop nozzle after letting it cool sufficiently. Touching the steam mop nozzle or the mop pads before they are sufficiently cooled may result in burns.

⚠ CAUTION

- Turn the water inlet caps to make sure they remain open when storing the water tank. If caps are closed and not properly dried, it may cause odour.
- Do not remove the water inlet caps from the water tank as the rubber caps may tear or break.

- Do not pull or stretch the rubber gasket on the water supply inlet. Doing so may tear or damage it.
- Do not add detergent, vinegar or baking soda to the water tank when washing it. Residues from these chemical agents are not easily removed in the water tank, which may soil the floor.
- After cleaning, gently wipe off any remaining water on the water supply inlet ❶ on the steam mop nozzle with a soft cloth. The water could drip onto the floor and damage it.

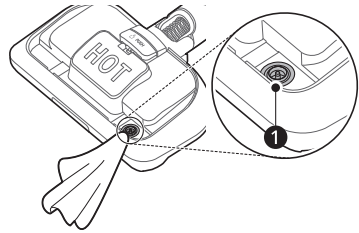

- 1 Open the 2 water inlet caps ❶ on the side of the water tank and empty the water tank. Shake the water tank to remove the remaining water. Do not tap the water tank against any surface.

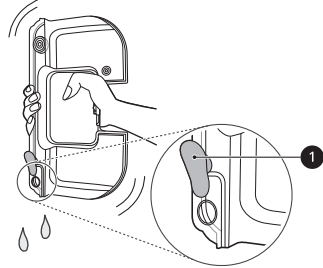

- 2 Leave the water inlet cap open and allow the water tank to dry in a well-ventilated area out of direct sunlight for at least 24 hours.

- Keep the water tank after water is completely empty and dry. Moisture or residual water in the tank may cause odour.

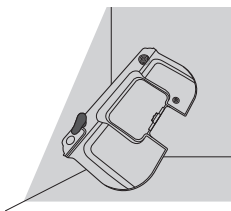

Drying the Mop Pads

After using the mop pads, hand wash them and allow them to dry before storing them.

⚠ CAUTION

- Do not use as follows, as it may become deformed.
 - Do not use bleach or fabric softener when washing the mop pads.
 - Do not dry the pads in a clothes dryer.
 - Do not boil the mop pad.

- 1 Separate the mop pads from the mop attachment plate.
- 2 Hand wash the pads with a neutral detergent.
 - Storing mop pads in a damp state can result in an unpleasant odour. Set the pads in a well-ventilated area out of direct sunlight for at least 24 hours or until completely dry.

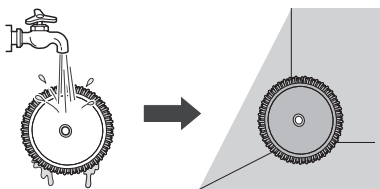

Using the Nozzles and Tools

Before Using the Nozzles and Tools

Some accessories are only available on some models.

Specialized attachments can help you clean more effectively. Tools and nozzles can be attached to the product body or the extension pipe.

- Adjust the suction power if the inlet gets stuck on the floor, carpet, or bedding.
- Each Nozzle is equipped with a motor and may make a sound when operating.

⚠ CAUTION

- Do not use the Multi-Surface Nozzle or Slim Hard Floor Nozzle on PVC or polyurethane mats for infants and children. The mat may stick to the nozzle, making it difficult to operate, causing damage to the mat or static electricity on the appliance. Clean mats using the crevice tool.

Multi-surface Nozzle

Use this nozzle to clean carpets or rugs.

- If used on hard flooring, this nozzle will be noisy.

Wide Hard Floor Nozzle

Use this nozzle to clean hard floor surfaces.

- While cleaning, accidentally pressing the **PUSH** button on the nozzle may remove the brush. Please re-attach the brush again.

Pet Nozzle

It is suitable for soft surfaces and pet hair removal.

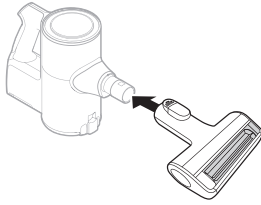

- Use it with the **Turbo** mode to clean pet hair out of furniture, mats, or tight areas like corners.

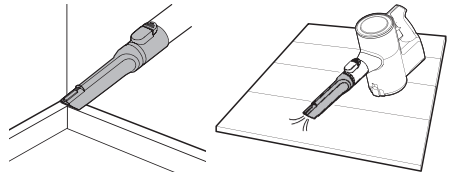

⚠ CAUTION

- Do not use the nozzle following surface. It may cause scratch or damage. Especially, do not clean a coated or lacquered floor. If used repeatedly, the coating may wear off.
 - Clothing, bedding
 - Leather cushioned sofas, cushions
 - Carpet
 - Vinyl flooring, tiles, marble, etc.

Combination Tool

Can be used in either crevice mode or brush mode for cleaning corners or small gaps where dust and dirt gather.

• Crevice Mode

Use the tool in the crevice mode to clean flat surfaces such as sofas or mattresses.

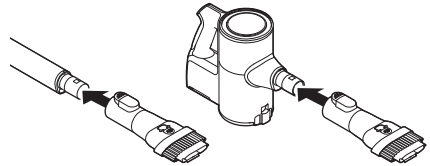

• Brush Mode

Use the tool in the brush mode to clean delicate surfaces such as frames or furniture.

- To convert modes, press the adjustment button **1** and push forward.

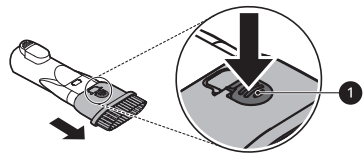

Bedding Nozzle

This nozzle lets you clean sheets and bedding more effectively. It removes dust in bedding using strong suction and a punching motion.

- Lower the suction level when vacuuming bedding such as duvet covers to avoid the thin fabric getting sucked into the nozzle.

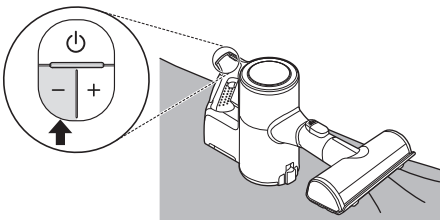

Crevice Tool

Use this tool to remove dust from corners or narrow spaces.

- Use it for areas with static electricity such as mats.

Hard Dirt Tool

Firm bristles remove solidified dirt from hard surfaces. Clean up hair or foreign objects that are entangled in carpets or rugs.

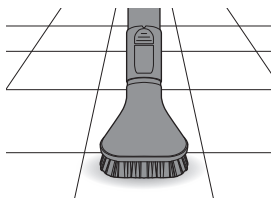

Mattress Tool

Use this tool to clean up dust and foreign objects from mattresses, delicate fabrics, and upholstery.

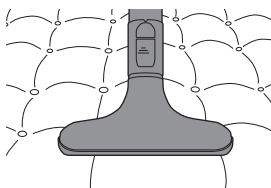

Flexible Crevice Tool

This tool is flexible and its length can be adjusted, making it especially useful for cleaning inside vehicles or in narrow spaces under and behind furniture where an angled tool is needed.

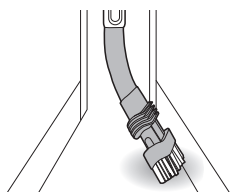

Using the Brush

To convert the tool from crevice to brush mode, press in on the sides of the brush head ① and pull the brush down.

- To convert back to the crevice mode, press in on the brush release button ② and slide the brush up.

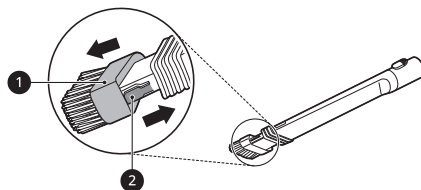

Adjusting the Length

To adjust the length of the tool, press and hold the release button ③ on the side of the tool. Pull or push on the brush head ④ to extend or retract the extension tube.

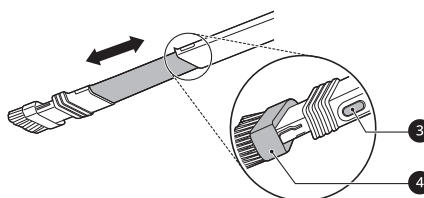

Multi-angle Tool

This tool has a soft brush that can be adjusted to a variety of angles, making it especially useful for cleaning vehicle consoles or the tops of furniture.

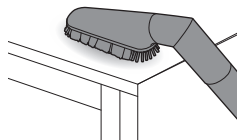

Flexible Hose Extension

Connect this flexible, extendable hose between the product body and the tools to clean hard to reach areas.

- The flexible hose extension cannot be used with the power drive Nozzle.

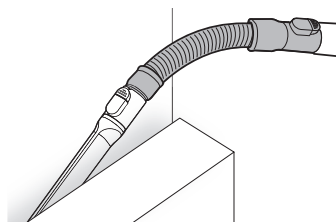

Using the Kompressor Lever

Use the Kompressor lever to compress hair and fibers inside the dust bin after vacuuming and before emptying the dust bin.

- The vacuum must be turned off before using the Kompressor lever.
- Compressing the dust clears it off the interior walls of the dust bin and allows you to vacuum for longer periods before emptying the dust bin. It also makes cleaning the dust bin easier and less messy.
- The dust bin must be at least half full for the compression plate to be effective.
- Press the Kompressor lever down several times to compress the dust and clean off the interior walls of the dust bin.

NOTE

- Do not force the Kompressor lever down if it does not travel down all the way or feels obstructed. Doing so can break the lever. If it cannot be pushed down, the cyclonic filter must then be removed and cleaned and dust tank checked for any obstructions.
-

SMART FUNCTIONS

Using LG ThinQ Application

The **LG ThinQ** application allows you to communicate with the appliance using a smartphone.

LG ThinQ Application Features

- **Setting the default mop operation**
 - This function allows the setting of the default operation mode of the Mop Nozzle.
- **Cleaning History**
 - Shows the cleaning history, such as monthly cleaning time, cleaning frequency, and cleaning mode, etc.

NOTE

- Assembled suction tool is displayed on the screen during cleaning.
- A notification is displayed on the screen if the pre-filter and the exhaust filter need cleaning.

Filter Cleaning Cycle Alarm

- After using the appliance for a certain period of time, a notification is displayed on the screen of your smartphone. Clean the exhaust filter or pre-filter, if necessary.

Cleaning Mode

- The cleaning mode you are using is displayed on the screen of your smartphone.

Filter Cleaning Guide

- Guide to cleaning the filters.

Smart Diagnosis™

- This function provides useful information for diagnosing and solving issues with the appliance based on the pattern of use.

NOTE

- If you change your wireless router, Internet service provider, or password, delete the connected appliance from the **LG ThinQ** application and connect it again.
- This information is current at the time of publication. The application is subject to change

for product improvement purposes without notice to users.

Installing LG ThinQ App and Connecting an LG Appliance

Models with QR Code

Scan the QR code attached to the product using the camera or a QR code reader app on your smartphone.

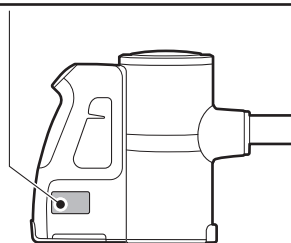

Models without QR Code

- 1 Search for and install the **LG ThinQ** app from the Google Play Store or Apple App Store on a smartphone.
- 2 Run the **LG ThinQ** app and sign in with your existing account or create an LG account to sign in.
- 3 Touch the add (+) button on the **LG ThinQ** app to connect your LG appliance. Follow the instructions in the app to complete the process.

NOTE

- You may be asked to provide a password to connect to the LG network (not your home network) during the Wi-Fi setup. The password is the last 4 characters of the network name, repeated twice, with no spaces. For example, if the network name appears as LG_XXXX_8b92, then you would enter 8b928b92 as your password. The password is case sensitive and the last 4 characters are unique to your appliance.
- To verify the Wi-Fi connection, check that the  icon on the control panel is lit.
- The appliance supports 2.4 GHz Wi-Fi networks only. To check your network frequency, contact your Internet service provider or refer to your wireless router manual.
- LG ThinQ** is not responsible for any network connection problems or any faults, malfunctions, or errors caused by network connection.
- If the appliance is having trouble connecting to the Wi-Fi network, it may be too far from the router. Purchase a Wi-Fi repeater (range extender) to improve the Wi-Fi signal strength.
- The Wi-Fi connection may not connect or may be interrupted because of the home network environment.
- The network connection may not work properly depending on the Internet service provider.
- The surrounding wireless environment can make the wireless network service run slowly.
- If the appliance cannot be registered due to problems with the wireless signal transmission, unplug the appliance and wait about a minute before trying again.
- If the firewall on your wireless router is enabled, disable the firewall or add an exception to it.
- The wireless network name (SSID) should be a combination of English letters and numbers. (Do not use special characters.)
- Smartphone user interface (UI) may vary depending on the mobile operating system (OS) and the manufacturer.
- If the security protocol of the router is set to **WEP**, network setup may fail. Change the

security protocol (**WPA2** is recommended) and connect the product again.

Connecting the Appliance to LG ThinQ

Wi-Fi Indicator Status

Indicator Status	Description
Blinking	The appliance is connecting.
ON	The appliance has finished connecting. The appliance is connected to Wi-Fi.
OFF	The appliance has been disconnected.

Connecting the Appliance Initially

Select your appliance on menu by pressing the **Add a Product (+)** button. Follow instructions in the **LG ThinQ** to connect your appliance.

Connecting Additional Users

Remove the appliance from the charging station. Follow the instructions under **Connecting the Appliance Initially**.

NOTE

- The usage history will be reset if you delete a connected appliance in **LG ThinQ**.
- If the Wi-Fi signal is weak, the appliance may be temporarily disconnected to the application. When the Wi-Fi signal moves to the normal position, the appliance is connected to the application again.

Turning Wi-Fi On/Off on the Appliance

Disconnecting from Wi-Fi

To save energy, turn off the Wi-Fi function by pressing the **Wi-Fi** button for 3 seconds while the appliance is charging on the charging station.

Reconnecting to Wi-Fi

Follow the steps below on the appliance.

- 1 Press and hold the **Wi-Fi** button for 3 seconds until the  icon blinks in the display.
- 2 Press the **Wi-Fi** button for 3 seconds again.
 - After the icon turns off, wait for a while and turn it on again.
 - The time before the icon turns on may vary depending on the network environment.

RF Radiation Exposure Statement

RF Radiation Exposure Statement This equipment complies with radiation exposure limit (<4.0 W/kg for extremity (hand) exposure condition) set forth for an uncontrolled environment.

Open Source Software Notice Information

To obtain the source code that is contained in this product, under GPL, LGPL, MPL, and other open source licenses that have the obligation to disclose source code, and to access all referred license terms, copyright notices and other relevant documents, please visit <https://opensource.lge.com>.

LG Electronics will also provide open source code to you on CD-ROM for a charge covering the cost of performing such distribution (such as the cost of media, shipping, and handling) upon email request to opensource@lge.com.

This offer is valid to anyone in receipt of this information for a period of three years after our last shipment of this product.

Smart Diagnosis Function

Use this feature to help you diagnose and solve problems with your appliance.

NOTE

- For reasons not attributable to LGE's negligence, the service may not operate due to external factors such as, but not limited to, Wi-Fi unavailability, Wi-Fi disconnection, local app store policy, or app unavailability.
- The feature may be subject to change without prior notice and may have a different form depending on where you are located.

Using LG ThinQ to Diagnose Issues

If you experience a problem with your Wi-Fi equipped appliance, it can transmit troubleshooting data to a smartphone using the **LG ThinQ** application.

- Launch the **LG ThinQ** application and select the **Smart Diagnosis** feature in the menu. Follow the instructions provided in the **LG ThinQ** application.

MAINTENANCE

Cleaning the Appliance

Before Cleaning the Appliance

To maintain the optimum suction power, the cyclonic mesh filter, the exhaust filter and the pre-filter should be cleaned regularly and washed under running water at least once a month.

- Turn off the power before cleaning the appliance.
- The frequency of cleaning varies depending on the usage environment and usage time. In a dusty environment, clean frequently.

⚠ WARNING

- Never wash the Nozzle, rotating brush or product body with water. Water could reach the motor and cause electric shock or fire.
- Do not allow foreign objects to enter the motor. Doing so may cause electric shock, fire or product damage.
- Do not insert fingers or sharp objects into the motor. Doing so could cause product damage, personal injury or electric shock.

⚠ CAUTION

- Do not apply force or allow impacts to the cyclonic mesh filter. Doing so could deform the filter, compromise product performance, or cause the product to malfunction.
- If the Kompressor lever does not return to the top, remove the cyclonic mesh filter from the dust bin and clean it. A clogged or dirty filter may cause poor cleaning results.

Removing Foreign Objects

If the appliance is clogged with foreign objects, the suction power changes, the motor cycles between low and high speed repeatedly, and the foreign objects clogging alarm icon blinks.

If clogging persists, the appliance will turn off automatically to prevent damage. Separate the

battery from the product body and remove the foreign objects before resuming use of the appliance.

- Check the inside of the product body, above the Kompressor working plate, the extension pipe, inlets, exhaust filter, pre-filter and cyclonic mesh filter for foreign objects.
- If the inlets are not completely blocked, the foreign objects clogging alarm indicator may not light up but the suction ability will be affected.
- If the sound of the appliance becomes loud or the cleaning results is poor, check for foreign objects.

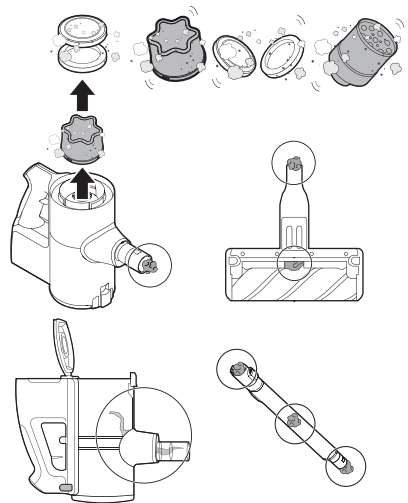

Cleaning the Dust Bin

Empty and clean the dust bin after every use.

- If the dust bin is completely full of dust or the filter is clogged, the suction power will be reduced.

⚠ CAUTION

- Do not use the appliance without the cyclonic mesh filter installed. Doing so could damage the appliance.

- 1 Remove the battery from the product body before cleaning the dust bin.
- 2 Push down the Kompressor lever **1** several times to collect and compact the dust from the outside of the cyclonic mesh filter and the interior walls of the dust bin.
 - Foreign objects which become lodged in the cyclonic mesh filter may be difficult to dislodge with the Kompressor lever. Remove the cyclonic mesh filter and use the provided cleaning brush to clean it.

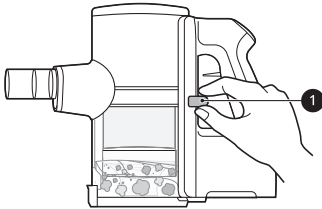

- Do not force the Kompressor lever down if foreign objects are caught around the working plate of the Kompressor system. Doing so may cause product damage.

- 4 Insert the crevice tool **4** into the cyclonic mesh filter **3** and turn it counterclockwise to remove the filter.

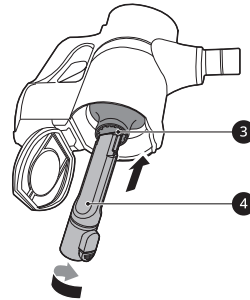

- 3 Press the dust bin cover release button **2** to open the dust bin cover. Shake the dust bin to empty it.
 - Be careful as dust or foreign objects may spill out when opening the dust bin. Empty the dust bin into a wastebasket or where dust and foreign objects can be easily removed.
 - The dust bin can be wrapped in a plastic bag to contain the dust when emptying the dust bin.

- 5 Wash the cyclonic mesh filter under running water.
 - To avoid odour and the malfunction of the motor, allow the cyclonic mesh filter to dry completely in a well-ventilated area out of direct sunlight for at least 24 hours before reassembling.

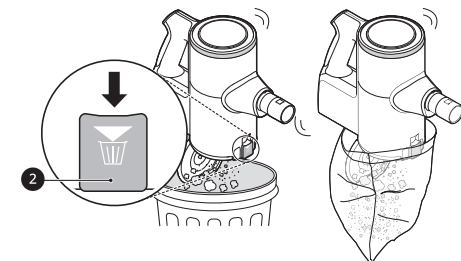
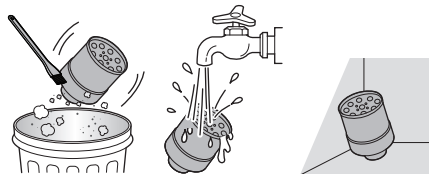

- 6 Use the combination tool **5** to clean out dust or foreign objects inside the dust bin.
 - Do not wash the product body or motor with water.

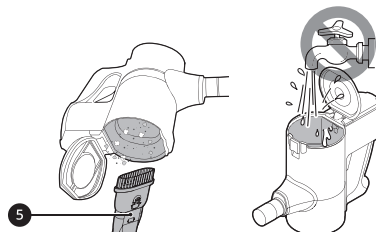

⚠ WARNING

- If the Kompressor lever does not slide down smoothly, foreign objects may be trapped between the dust bin and the cyclonic mesh filter. Clean the dust bin and cyclonic mesh filter to avoid product damage.

7 Turn the product body over and lift the Kompressor lever **6** up to clean the inside of the working plate with the provided cleaning brush.

- Do not push the Kompressor lever down hard. The working plate may be damaged.

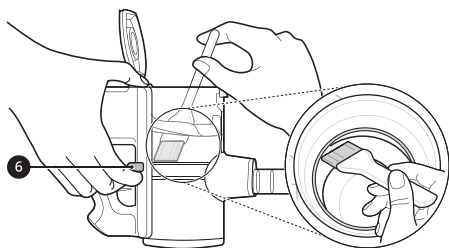

8 Turn the product body over again and shake it while pressing down the lever to remove the dust.

9 Wrap the provided cleaning brush with a wet paper towel, tucked into the slots **7** on the handle.

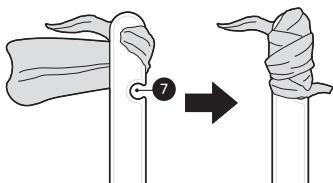

10 Turn the product body over, lift the Kompressor lever **8** up, and clean the inside of the working plate with the towel-wrapped brush handle.

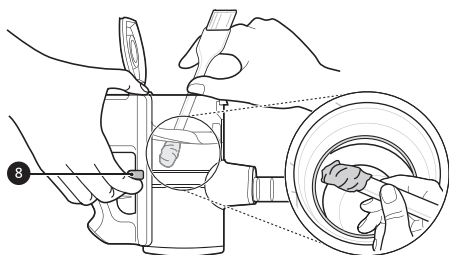

Cleaning the Filters

Clean the exhaust filter and the pre-filter when the filter cleaning icon  lights up.

- Clean the filters more frequently if the appliance is used regularly or in areas with a lot of dust.

⚠ CAUTION

- Do not use the appliance without the exhaust filter and pre-filter installed. Doing so could result in product damage.

1 Remove the battery from the product body.

2 Rotate the exhaust filter **1** to the unlocked position **2** to separate it from the product body.

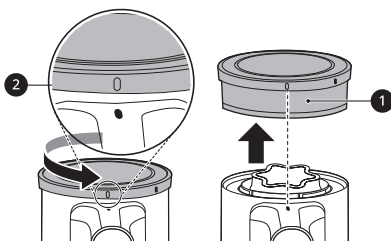

3 Grip the exhaust filter cover **3** and the exhaust filter **1** using both hands and rotate the exhaust filter cover while pressing the **PUSH** button in order to separate it from the exhaust filter.

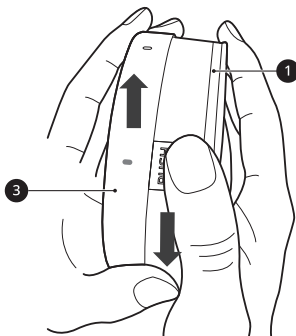

- 4 Lift out the pre-filter 4 from the product body.

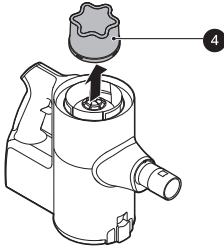

- 5 Use the combination tool 5 to clean any dust off the motor.

- Do not wash the motor with water.

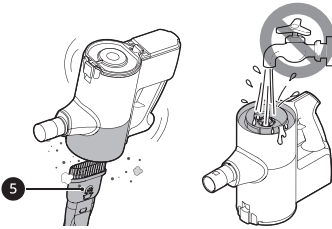

- 6 Clean filters by regularly brushing the dust off and wash them in running water at least once a month.

- To avoid odour and the malfunction of the motor, allow the exhaust filter to dry completely in a well-ventilated area out of direct sunlight for at least 24 hours before reassembling.

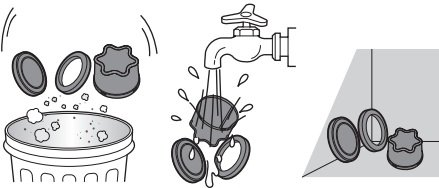

- 7 Align the lock position 6 of the exhaust filter cover with the letter "H" 7 of the PUSH button on the exhaust filter.

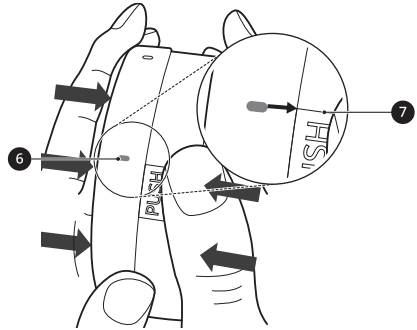

- 8 Push and insert the exhaust filter cover 3 into the exhaust filter 1 and rotate it to reassemble it and prevent it from falling out.

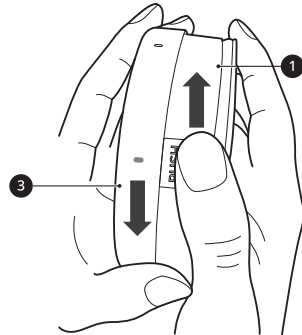

- 9 Insert the dried pre-filter and rotate the exhaust filter to the locked position 6 to reassemble it on the product body.

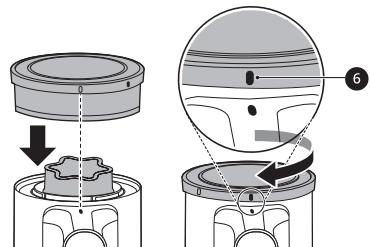

Cleaning the Nozzles

Clean the nozzle and rotating brush regularly.

⚠ CAUTION

- Always separate the nozzle from the product body or remove the battery before cleaning. If the nozzle starts to operate during cleaning, it could cause an injury.
- Keep fingers away from pinch points when assembling the nozzle on the appliance or the rotating brush on the nozzle.
- Do not use the rotating brush as a wet mop. It may cause product damage.
- Do not rinse or submerge the rotating brush or nozzle in water. It may cause product damage.

Cleaning the Multi-Surface Nozzle

Clean the brush and roller heads before each use.

- If the brush contains foreign objects, the brush may not spin or a noise may occur during operation.

- 1 Press the nozzle release button **1** to remove the nozzle from the extension pipe or product body.

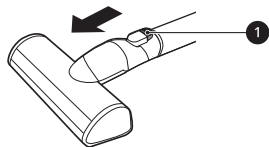

- 2 Turn the nozzle upside down and rotate the cover lock slot **2** counterclockwise.

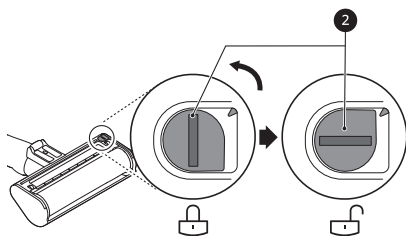

- 3 Pull the brush cover forward and pull the brush out.

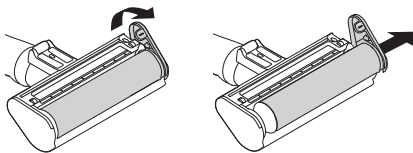

- 4 Attach the crevice tool to the product body and use the vacuum to remove foreign objects and dust from the brush and the bottom of the nozzle.

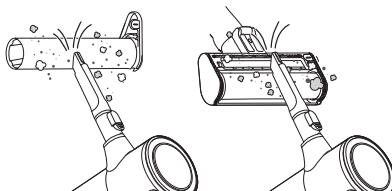

- 5 Use a damp towel or cloth to remove any remaining foreign objects and dust from the brush and the bottom of the nozzle. Remove foreign objects, debris and hair from all Rollers of the nozzles using tweezers.

- Wrap the handle of the cleaning brush with a wet towel or cloth and use it to clean the rotating brush and nozzle.

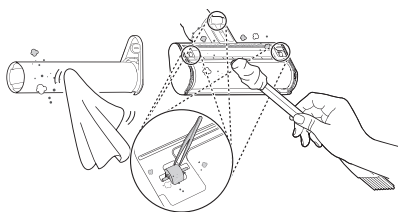

- 6 Slide the brush back into the nozzle and rotate the cover back into place. Turn the cover lock clockwise to lock the cover.

Cleaning the Wide Slim Hard Floor Nozzle

⚠ CAUTION

- Be careful not to injure your fingers when using a screwdriver.

- 1 Press the nozzle release button ❶ to remove the nozzle from the extension pipe or product body.

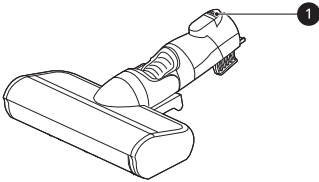

- 2 Turn the nozzle upside down and remove the rotating brush while holding down the **PUSH** button on the nozzle.

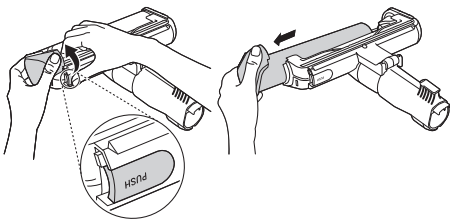

NOTE

- When removing the rotating brush from the nozzle, part of the edge of the rotating brush may detach. Reassemble the rotating brush by holding the rotating brush and the detached part of the edge and pushing them in until a click is heard.

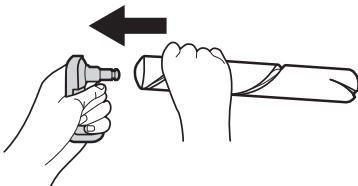

- 3 Attach the crevice tool to the product body and use the vacuum to remove foreign objects and dust from the brush and the bottom of the nozzle.

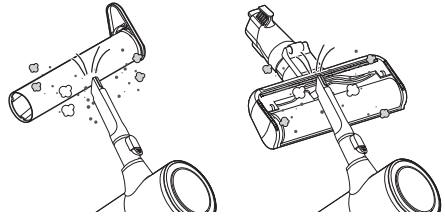

- 4 Use a damp towel or cloth to remove any remaining foreign objects and dust from the brush and the bottom of the nozzle.
 - Do not wash the rotating brush and the nozzle with water or immerse them in water.
 - Wrap the handle of the cleaning brush with a wet towel or cloth and use it to clean the rotating brush and nozzle.

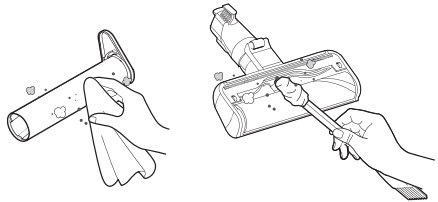

- 5 Remove foreign objects, debris and hair from all Rollers of the nozzles using tweezers.

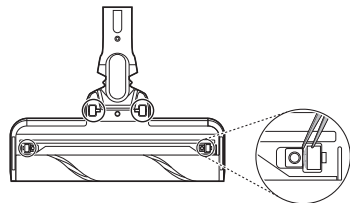

- 6** You can clean the inside of the small roller by inserting a flat-head screwdriver into the groove and removing the fixing part.

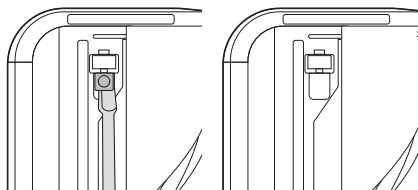

- 7** Reassemble the small roller and the fixing part and make sure that they are properly attached.

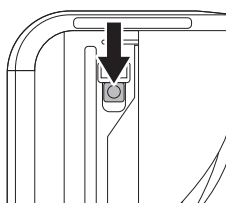

- 8** When holding both ends of the rotating brush and pulling it out, the rotating brush and part of the edge will separate. If hair is wrapped around the edge of the rotating brush, remove the rotating brush and clean it.

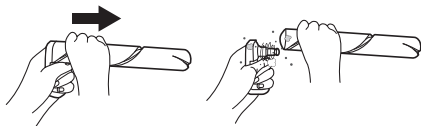

- 9** Reassemble the rotating brush and the part of the edge and insert the end of the rotating brush into the groove at the end of the nozzle.

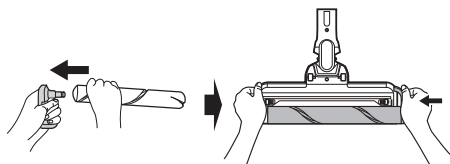

- 10** Slide the brush back into the nozzle until it clicks into place.

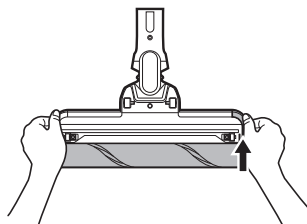

Cleaning the Pet Nozzle

- 1** Press the nozzle release button **1** to remove the nozzle from the extension pipe or product body.

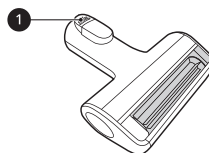

- 2** Remove the rotating brush while holding down the **PUSH** button on the nozzle.

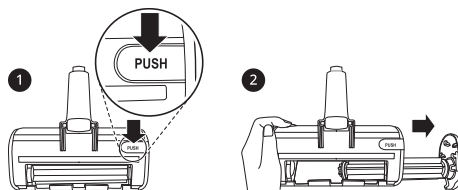

- 3** Attach the crevice tool to the product body and use the vacuum to remove foreign objects and dust from the brush and the bottom of the nozzle.

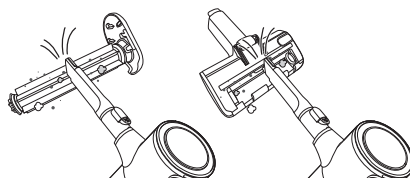

- 4** Use a damp towel or cloth to remove any remaining foreign objects and dust from the brush and the bottom of the nozzle. Remove

foreign objects, debris and hair from all Rollers of the nozzles using tweezers.

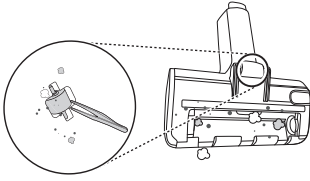

hair from all Rollers of the nozzles using tweezers.

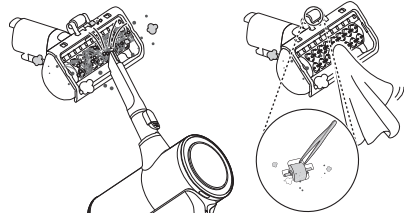

- 5** Insert the left side of the brush **2** into the groove **3** inside the nozzle.

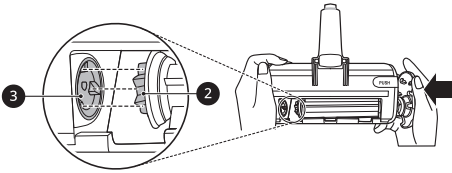

- 6** Press the cover of the brush to lock the brush until a clicking sound is heard.

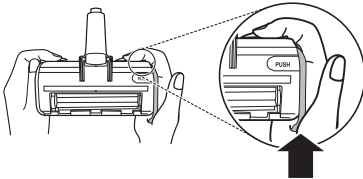

Cleaning the Steam Mop Nozzle

⚠ WARNING

- After steam cleaning, hot steam may become water droplets and hot water may flow from the inlet. After cooling the product sufficiently, clean the nozzle and store the product in the charging station.

- 1** Press the nozzle release button to remove the steam mop nozzle from the extension pipe and turn the nozzle upside down.

- 2** After steam cleaning, steam may become water droplets and said water droplets may remain under the nozzle along with dirt. Use a lightly dampened towel or cloth to remove any dirt or debris that remains under the steam nozzle and in the dust suction part.

- Remove foreign objects, debris and hair from all Rollers of the nozzle using tweezers.

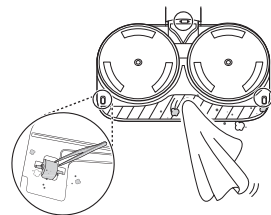

Cleaning the Bedding Nozzle

- 1** Press the nozzle release button to remove the nozzle from the extension pipe or product body and turn the nozzle upside down.

- 2** Attach the crevice tool to the product body and use the vacuum to remove foreign objects and dust from the bottom of the nozzle. Use a damp towel or cloth to remove any remaining foreign objects and dust from the bottom of the nozzle. Remove foreign objects, debris and

TROUBLESHOOTING

Before Calling for Service

Operation

Symptoms	Possible Cause & Solution
The appliance does not operate.	Battery is fully discharged. <ul style="list-style-type: none"> Charge the battery.
	Appliance is turned off. <ul style="list-style-type: none"> Press the Power button to turn on the appliance.
Suction power is too weak.	Dust bin is full of dust. <ul style="list-style-type: none"> Empty the dust bin.
	Filters are clogged. <ul style="list-style-type: none"> Clean the pre-filter and the exhaust filter.
	Inlet is clogged. <ul style="list-style-type: none"> Remove any foreign objects from inside the product body or the extension pipe.
	Foreign object is on rotating brush, or in inlet port. <ul style="list-style-type: none"> Remove any foreign objects (thread, hair) from the rotating brush or the inlet port.
The product body does not appear to be charging.	Power cord is unplugged. <ul style="list-style-type: none"> Plug the power cord securely into the outlet.
	Foreign object is on the charging terminals. <ul style="list-style-type: none"> Remove dirt or foreign objects from the charging terminals with a dry cloth.
Hot air is coming from the product body.	Motor is cooling. <ul style="list-style-type: none"> If the appliance is running normally, the hot air is a result of the motor cooling and is not a sign of malfunction.
The Kompressor lever does not return.	Foreign objects which become lodged in the cyclonic mesh filter may be difficult to dislodge with the Kompressor lever. <ul style="list-style-type: none"> Remove the cyclonic mesh filter and use the provided cleaning brush to clean it.
A strange odour is coming from the appliance.	Appliance was purchased within the last 3 months. <ul style="list-style-type: none"> The cleaner may emit a smell of rubber for about 3 months after purchase.
	Dust bin is full of dust. <ul style="list-style-type: none"> The dust in the bin may cause some odour. Empty the bin and clean it.

Symptoms	Possible Cause & Solution
A strange odour is coming from the appliance.	Foreign object is on the filter. <ul style="list-style-type: none"> The filter may emit an odour if it has not been cleaned for some time. Clean the pre-filter and exhaust filter regularly.
	Pre-filter, Exhaust Filter or the Cyclonic Mesh Filter were installed while damp or wet. <ul style="list-style-type: none"> Wash the filters with running water. To avoid odour, allow the pre-filter to dry completely in a well-ventilated area out of direct sunlight for at least 24 hours before reassembling.
	Exhaust filter was installed while damp or wet. <ul style="list-style-type: none"> Wash the exhaust filter with running water. To avoid odour, allow the exhaust filter to dry completely in a well-ventilated area out of direct sunlight for at least 24 hours before reassembling.
The appliance makes too much noise.	Vacuum cleaner is running in Turbo mode. <ul style="list-style-type: none"> The motor may be louder at the higher suction power settings. This is normal.
The appliance turns off unexpectedly or by itself after the motor speed fluctuates repeatedly.	Battery is not fully charged. <ul style="list-style-type: none"> The battery must be fully charged before cleaning. If the problem persists when the battery is fully charged and the pipes and attachments are clear from obstructions, contact an LG customer information centre for service.
	Foreign object is in the product body, extension pipe, inlet port or nozzle. <ul style="list-style-type: none"> Remove any foreign objects from the product body, extension pipe, inlet port or nozzle.
	Filters are clogged. <ul style="list-style-type: none"> Clean the pre-filter and the exhaust filter.
The rotating brush does not rotate.	Brush is improperly installed. <ul style="list-style-type: none"> Remove the brush, clean it if necessary and attach it again.
	Foreign object is on rotating brush. <ul style="list-style-type: none"> Remove any foreign objects from the rotating brush.

Steam Mop Nozzle

Symptoms	Possible Cause & Solution
One or both mop attachment plate does not rotate.	Mop pads are improperly installed. <ul style="list-style-type: none"> Remove the mop pads, clean them if necessary and attach them again.

Symptoms	Possible Cause & Solution
<p>One or both mop attachment plate does not rotate.</p>	<p>The motor protection function has been activated from overload and the mop attachment plate stopped rotating.</p> <ul style="list-style-type: none"> • There is a lot of friction and a load is applied to the steam mop nozzle when the steam mop is used as shown below conditions. The motor protection function has stopped one or both mop pad attachment plate rotating to prevent the motor from overheating. Use the steam mop nozzle after cooling the heat for about one hour in a cool, well-ventilated place. <ul style="list-style-type: none"> - The mop pads are overlapped. - There's a foreign object stuck in the mop attachment plate. - The steam mop nozzle is used on PVC or PU mat for infants or children. - The steam mop nozzle is used while standing vertically and applied excessive force or stepped on. - The steam mop nozzle is used for a long time.
	<p>Foreign object is between mop attachment plate and mop pads.</p> <ul style="list-style-type: none"> • Remove foreign objects from the steam mop nozzle and the mop attachment plate and press the power button to resume use.
<p>There is no water coming out of the steam mop nozzle.</p>	<p>Water tank is empty.</p> <ul style="list-style-type: none"> • Fill the water tank. Remove the battery or detach the nozzle before filling the water tank.
	<p>Water tank is improperly attached to the steam mop nozzle.</p> <ul style="list-style-type: none"> • Properly attach the water tank to the steam mop nozzle. Remove the battery or detach the nozzle before properly securing the water tank to the nozzle.
	<p>Water supply adjustment button is set to STOP when using normal mop mode.</p> <ul style="list-style-type: none"> • Press the High or Low water adjustment button all the way down. The water will not come out if the button is set to STOP when using normal mop mode.
	<p>The water outlet was clogged by hard water scale or other foreign substances.</p> <ul style="list-style-type: none"> • Use a sharp pin to remove the blockage.
<p>There is moisture in the water tank.</p>	<p>Water tank is not allowed to dry completely after use.</p> <ul style="list-style-type: none"> • Empty the water tank, set it out of direct sunlight, and allow it to dry completely after use.
<p>A strange odour is coming from the appliance.</p>	<p>Foreign object is on the dust inlet of the steam mop nozzle.</p> <ul style="list-style-type: none"> • Wet dust in the steam mop nozzle may result in odour. Make sure to wipe the dust inlet of the steam mop nozzle with a wet wipe after each use.
<p>Mop pads make the floor dirty.</p>	<p>Mop pads are not cleaned properly after use.</p> <ul style="list-style-type: none"> • Clean the mop pads thoroughly after each use. Using soiled mop pads may make the floor dirtier.

Symptoms	Possible Cause & Solution
<p>Mop pads make the floor dirty.</p>	<p>There is a lot of dust or liquid spilled on the floor.</p> <ul style="list-style-type: none"> • Before cleaning in steam mode or normal mop mode, clean a place with a lot of dust using the suction function and wipe off any liquid. Otherwise, the dust may clump or the liquid may spread, causing the floor to become dirty.
<p>Steam does not come out of the steam mop nozzle. (When the battery pocket LED grows red)</p>	<p>The steam outlet is in contact with the mop pads to fully deliver steam to the mop pads, so steam is invisible.</p> <ul style="list-style-type: none"> • While the steam mode is being activated, the battery pocket LED glows red.
<p>Steam does not come out of the steam mop nozzle. (When the battery pocket LED is off or blinks)</p>	<p>The battery is not installed in the battery pocket or the battery in the battery pocket is discharged.</p> <ul style="list-style-type: none"> • Assemble the battery pocket to the steam mop nozzle and install the fully charged battery. When you press the Power button on the main body, the battery pocket LED will turn on and the steam mode will be activated. <p>The water tank is empty.</p> <ul style="list-style-type: none"> • If there is no water in the water tank, the battery pocket LED will blink and steam won't come out. Separate the steam mop nozzle from the vacuum cleaner and the extension pipe, remove the battery pocket and fill the water tank with water. <p>The mop pads are not attached to the mop attachment plate.</p> <ul style="list-style-type: none"> • If you activate the steam mode without attaching the mop pads, steam will not come out and the battery pocket LED will turn on and off immediately. Power off the main unit and align and attach the centre of the mop pad with the centre of the mop attachment plate. <p>The steam mop nozzle was left in place while the steam mode was being activated.</p> <ul style="list-style-type: none"> • If the steam mop nozzle is left in one place and not moved, steam will not be sprayed to prevent damage to the floor. When you start moving the product, steam will be sprayed again. • If the steam mop nozzle is left in one place for more than 1 minute and not moved, the rotation of the mop attachment plate also stops. To use the steam mode, power the main unit off and on. <p>The nozzle is lifted away from the floor or is tilted.</p> <ul style="list-style-type: none"> • Steam will not come out if the nozzle is lifted away from the floor or is tilted. Place it on a flat surface to use it.
<p>The battery pocket LED of the steam mop nozzle blinks.</p>	<p>The battery in the battery pocket is low.</p> <ul style="list-style-type: none"> • If the battery is low while using the steam mode, the battery pocket LED will blink. When the battery is discharged, it will switch to the normal mop mode.

Symptoms	Possible Cause & Solution
The battery pocket LED of the steam mop nozzle blinks.	<p>There is no water in the water tank while using the steam mode.</p> <ul style="list-style-type: none"> If there is no water in the water tank, the battery pocket LED will blink and steam won't come out. Separate the steam mop nozzle from the vacuum cleaner and the extension pipe, remove the battery pocket and fill the water tank with water.
	<p>It malfunctions.</p> <ul style="list-style-type: none"> If the steam mop nozzle malfunctions, the battery pocket LED will blink rapidly and the alarm will repeat. If occurs again even after powering the main unit off and on, stop using it and contact an LG customer information centre for service.
The appliance makes too much noise.	<p>This is the sound generated when the pump at the inlet of the mop is operating.</p> <ul style="list-style-type: none"> This is normal.
	<p>The mop pads were improperly attached on the plates.</p> <ul style="list-style-type: none"> Align and attach the centre of the mop pad with the centre of the mop attachment plate.

Wi-Fi

Symptoms	Possible Cause & Solution
Your home appliance and smartphone are not connected to the Wi-Fi network.	<p>Battery is fully discharged.</p> <ul style="list-style-type: none"> Charge the battery, then register your appliance on LG ThinQ.
	<p>The password for the Wi-Fi that you are trying to connect to is incorrect.</p> <ul style="list-style-type: none"> Find the Wi-Fi network connected to your smartphone and remove it, then register your appliance on LG ThinQ.
	<p>Mobile data for your smartphone is turned on.</p> <ul style="list-style-type: none"> Turn off the Mobile data of your smartphone and register the appliance using the Wi-Fi network.
	<p>The wireless network name (SSID) is set incorrectly.</p> <ul style="list-style-type: none"> The wireless network name (SSID) should be a combination of English letters and numbers. (Do not use special characters.)
	<p>The router frequency is not 2.4 GHz.</p> <ul style="list-style-type: none"> Only a 2.4 GHz router frequency is supported. Set the wireless router to 2.4 GHz and connect the appliance to the wireless router. To check the router frequency, check with your Internet service provider or the router manufacturer.

Symptoms	Possible Cause & Solution
Your home appliance and smartphone are not connected to the Wi-Fi network.	The distance between the appliance and the router is too far. <ul style="list-style-type: none">• If the distance between the appliance and the router is too far, the signal may be weak and the connection may not be configured correctly. Move the location of the router so that it is closer to the appliance.

