

Miele

Operating instructions



Cordless vacuum cleaner

AU, NZ

HS19

M.-Nr. 11 843 120

Contents

Warning and Safety instructions	4
Safety instructions and warnings for AP01 battery, LG01/LG02 charger, LS03 charger cradle (depending on the model)	9
Guide to the appliance	14
Caring for the environment	16
Installation and connection	18
Assembling the vacuum cleaner	18
Using the PowerUnit solo	18
Connecting the Comfort handle	19
Connecting the PowerUnit and the suction tube	20
Inserting the battery	21
Connecting the Electrobrush	21
General battery information	22
Charging the battery (without wall mounting)	23
Charging the battery (with wall mounting)	23
Wall mounting	24
Battery charging state indicator (while charging)	27
Battery charging state indicator (while in use)	27
Using the supplied accessories	28
Accessories holder for the suction tube	28
Multi Floor XXL Electrobrush	29
Carpet Care roller brush	29
Hardfloor Care soft roller (HX HC)	30
Electro Compact handheld brush (HX SEB)	31
Additional battery (HX LA)	31
Battery charger cradle (HX LS)	32
Use	33
Switching on and off	33
Selecting the suction power level	33
Carpet protective function	33
Illuminating the work area	34
Self-standing function for short pauses in vacuuming	34
Maintenance	35
Purchasing accessories	35
Filter system	36
Activating the ComfortClean function	36
Emptying the dust container	37
Cleaning the pre-filter and fine dust filter	38



Contents

Cleaning the dust container	40
Cleaning the Electrobrush/handheld brush.....	40
Replacing the rechargeable battery	41
Error messages	42
Problem solving guide	43
Service	46
Contact in case of malfunction	46
Warranty	46
Cleaning and care	47
Optional accessories	48
Purchasing accessories	48
Electrical connection	50

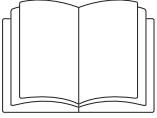
Warning and Safety instructions



► It is essential to read these instructions.

  **WARNING AU/NZ!** Keep batteries out of reach of children.

Coin or button batteries containing lithium can cause severe or fatal injuries within 2 hours of being swallowed or placed inside any part of the body. Non-lithium batteries can also cause serious injuries if swallowed or placed inside any part of the body. Even flat batteries can still be dangerous. If you suspect a child has swallowed a battery or placed a battery inside any part of their body, seek medical advice immediately (Australia: Poisons Information Centre, Tel. 13 11 26; NZ: National Poisons Centre, Tel. 0800 764 766). Examine devices and make sure the battery compartment is correctly secured, e.g. that the screw or other mechanical fastener is tightened. Do not use if compartment is not secure. Used batteries must be kept away from children while awaiting disposal and must be disposed of in a safe manner.

Warning and Safety instructions

This vacuum cleaner conforms to current safety requirements. Inappropriate use can lead to personal injury and damage to property.

Please read the operating instructions before using the vacuum cleaner and charging the battery for the first time. They contain important information on the safety, use and maintenance of the vacuum cleaner. This will prevent both personal injury and damage to the appliance.

In accordance with standard IEC 60335-1, Miele expressly and strongly advises that you read and follow the instructions in the “Installation and connection” section as well as the safety instructions and warnings.

Miele cannot be held liable for injury or damage caused by non-compliance with these instructions.

Keep these operating instructions in a safe place and pass them on to any future owner/operator.

Always switch the vacuum cleaner off when you have finished using it, before changing any accessories, as well as for maintenance work, cleaning and troubleshooting. Use the On/Off switch on the Comfort handle to do this.

Correct application

- ▶ This vacuum cleaner is intended for cleaning flooring in domestic households and similar residential environments. This vacuum cleaner is not suitable for use on construction sites.
- ▶ This vacuum cleaner is not intended for outdoor use.
- ▶ This vacuum cleaner can be used for all normal cleaning of carpets, rugs and robust hard flooring.
- ▶ This vacuum cleaner is intended for use at altitudes of up to 4000 m above sea level.

Warning and Safety instructions

- ▶ The vacuum cleaner must only be used to vacuum dry floor surfaces. Do not vacuum people or animals. Any other types of use, modifications or alterations are not permitted.
- ▶ The vacuum cleaner can only be used by people (including children) with reduced physical, sensory, or mental capabilities, or lack of experience or knowledge, if they are supervised whilst using it or have been shown how to use it in a safe way and understand and recognise the consequences of incorrect operation.

Safety with children

- ▶ Older children may only use the vacuum cleaner without supervision if they have been shown how to use it in a safe manner. Children must be able to understand and recognise the possible dangers caused by incorrect operation.
- ▶ Young children must be kept away from the vacuum cleaner unless they are constantly supervised.
- ▶ Children must not be allowed to clean or maintain the vacuum cleaner unsupervised.
- ▶ Please supervise children in the vicinity of the vacuum cleaner and do not let them play with it.
- ▶ Danger of suffocation. Packaging, e.g. plastic wrappings, must be kept out of the reach of babies and children. Whilst playing, children could become entangled in packaging or pull it over their head and suffocate.

Technical safety

- ▶ The vacuum cleaner operates at 25.2 V.



It is classified as a class III appliance.

This appliance is supplied by a safety extra-low voltage (SELV) power source where the voltage is low enough to protect users from the risk of electrical shock. A Class II charger is used for supplying power to charge the vacuum cleaner.

- ▶ Compare the connection data on the data plate of the charger (voltage and frequency) with that of the mains electricity supply. This data must match exactly. Without modifications, the charger is suitable for 50 Hz and 60 Hz.

- ▶ The mains electrical outlet must be fitted with an appropriate circuit breaker.

- ▶ Before using the vacuum cleaner and its accessories, check for any visible signs of damage. Do not use a damaged appliance.

- ▶ The Miele Multi Floor XXL Electrobrush and the Miele Electro Compact handheld brush (varies according to the model) are additional motor-driven devices designed specially for this Miele vacuum cleaner. For safety reasons, the vacuum cleaner must not be used with a different Miele Electrobrush/handheld brush or an Electrobrush/handheld brush produced by another manufacturer.

- ▶ Before and during use, make sure that no coarse dirt or debris is/gets trapped in the bottom of the Multi Floor XXL Electrobrush or in the bottom of the Electro Compact handheld brush* (*depending on model).

- ▶ Store the vacuum cleaner and all accessories at an ambient temperature between 0 °C and 45 °C.

- ▶ Repairs should only be undertaken by a Miele authorised service technician. Otherwise the warranty will be invalidated.

Warning and Safety instructions

- ▶ Repairs and other work by unqualified persons can cause considerable danger to users.
- ▶ If the vacuum cleaner is to be stored unused for a long period, the battery should be removed.
- ▶ The supply terminals must not be short-circuited.

Correct use

- ▶ Do not use the vacuum cleaner without the dust container, pre-filter and fine dust filter fitted.
- ▶ Do not vacuum up anything which has been burning or is still glowing e.g. cigarettes, ashes or coal, whether glowing or apparently extinguished.
- ▶ Do not use the vacuum cleaner to vacuum up any water, liquid or damp dirt. Wait until any freshly cleaned or shampooed rugs or carpets are completely dry before attempting to vacuum.
- ▶ Do not use the vacuum cleaner to vacuum toner dust. Toner, such as that used in printers and photocopiers, can conduct electricity.
- ▶ Do not vacuum up any inflammable or combustible liquids or gases and do not vacuum in areas where such substances are stored.
- ▶ Never touch the roller brush of the Multi Floor XXL Electrobrush or the Electro Compact handheld brush (varies according to the model) while it is rotating.
- ▶ Do not use the Multi Floor XXL Electrobrush or the Electro Compact handheld brush (varies according to the model) at head height.
- ▶ Do not vacuum at head height and do not let the suction get anywhere near a person's head.

Safety instructions and warnings for AP01 battery, LG01/LG02 charger, LS03 charger cradle (depending on the model)

Safety with children

- ▶ People (including children) with reduced physical, sensory or mental capabilities, or lack of experience or knowledge, who are unable to use the LG01/LG02 charger or LS03 charger cradle safely may only use this vacuum cleaner if they are supervised whilst using it or have been shown how to use it in a safe way and understand and recognise the consequences of incorrect operation.
- ▶ Keep the AP01 battery out of the reach of children.
- ▶ Children must be kept away from the LG01/LG02 charger and LS03 charger cradle unless they are constantly supervised.
- ▶ Do not let children play with the chargers.

Technical safety

- ▶ The AP01 battery, the LG01/LG02 charger and the LS03 charger cradle are designed for use with the Miele HS19 vacuum cleaner. For safety reasons, the vacuum cleaner must not be used with a battery, charger or charger cradle produced by another manufacturer.
- ▶ Only the LG01/**xx** or LG02/**xx** charger supplied or the LS03/**xx** charger cradle supplied or purchased as an optional accessory should be used to charge the AP01 battery.
xx stands for 01, 02, 03, 04, 05, 06, 07 or 08; these numbers identify the version of your LG01/LG02 charger and your LS03 charger cradle:

Warning and Safety instructions

XX	LG01/LS03	LG02
01	AT, BE, BG, CH, CL, CZ, DE, DK, EE, ES, FI, FR, GR, HR, HU, IT, KZ, LT, LU, LV, NL, NO, PL, PT, RO, RS, RU, SE, SI, SK, TR, UA, ZA	AT, BE, BG, CH, CL, CZ, DE, DK, EE, ES, FI, FR, GR, HR, HU, IT, KZ, LT, LU, LV, NL, NO, PL, PT, RO, RS, RU, SE, SI, SK, TR, UA, ZA
02	AE, HK, IE, MY, SG, UK	AE, HK, IE, MY, SG
03	CA, MX, US	CA, JP, MX, US
04	AU, NZ	AU, NZ
05	CN	CN
06	KR	KR
07	JP	UK
08	IN	

► If you are using a mains plug adapter, make sure that it is approved for continuous operation.

► Temporary or permanent operation with a self-sufficient or non-mains synchronous energy supply system (e.g. isolated networks, back-up systems) is possible. A requirement for the operation is that the energy supply system complies with all current local and national requirements that apply to stand-alone, solar and/or battery systems.

The protective measures provided in the domestic installation and in this Miele product must also be assured in their function and operation in isolated operation or in non-mains synchronous operation, or replaced with equivalent measures in the installation.

► Charge and use the battery at an ambient temperature between 0 °C and 45 °C.

Using the battery outside of this ambient temperature range will limit its performance.

Warning and Safety instructions

- ▶ Stop using the AP01 battery immediately if you notice an unusual smell from it, if liquid is leaking from it, if it is significantly overheating or if it is discoloured or deformed. Dispose of the AP01 battery immediately (see safety notice “Disposing of the AP01 battery” at the end of this chapter as well as “Caring for the environment – Disposing of old batteries”).
- ▶ Batteries will deplete over time. They can then leak corrosive fluids. Avoid contact with the eyes and skin. In the event of contact, rinse thoroughly with water and seek medical advice.
- ▶ To deal with leaking batteries, refer to the Safety Data Sheet (contact Miele to request a copy).
- ▶ The AP01 lithium-ion battery is subject to the dangerous goods legislation. The user is permitted to transport the AP01 battery by road, but may be subject to further requirements. Only send AP01 batteries that are undamaged and have been fully run down. Insulate the metal contacts with adhesive tape to prevent short circuits. Pack the AP01 battery in such a way that it is not able to move around inside the packaging.

Correct use

- ▶ Do not drop or throw the AP01 battery. For safety reasons, do not continue to use an AP01 battery which has been damaged.
- ▶ Keep the AP01 battery away from naked flames or other heat sources. Do not heat the AP01 battery. Do not expose the rechargeable battery to direct sunlight.
- ▶ Do not dismantle the AP01 battery.
- ▶ Do not cause a short circuit by bridging the contacts of the AP01 battery, either unintentionally or deliberately.
- ▶ Do not allow the AP01 battery to come into contact with liquids.

Warning and Safety instructions

- ▶ Disposing of the AP01 battery: remove the AP01 battery from the vacuum cleaner. Insulate the metal contacts with adhesive tape to prevent short circuits. Dispose of the AP01 battery in a municipal recycling facility. Do not dispose of the AP01 battery with your household waste.
- ▶ The rechargeable battery must be removed before the appliance is scrapped.

Cleaning

- ▶ Do not immerse the vacuum cleaner or any accessories supplied with it in water.
- ▶ The Multi Floor XXL Electrobrush, the Electro Compact handheld brush (depending on the model), the PowerUnit, the suction tube and the Comfort handle all contain electrical wires. The plug connectors must not come into contact with water. Danger of electric shock. They should only be cleaned with a dry cloth.
- ▶ Clean the vacuum cleaner and accessories only with a dry or slightly damp cloth when disconnected from the power supply. Exception:
 - Dust container: empty the dust container and remove the pre-filter. Clean the dust container using water and mild washing-up liquid only. Then dry the dust container carefully. Replace the pre-filter in the dust container.

Accessories and spare parts

- ▶ Only use genuine accessories with the “ORIGINAL Miele” logo on the packaging. The manufacturer cannot otherwise guarantee the safety of the product.
- ▶ Miele can only guarantee the safety of the appliance when genuine Miele replacement parts are used. Faulty components must only be replaced with genuine Miele replacement parts.

Transport

- ▶ The packaging material protects the vacuum cleaner from transport damage. We recommend you keep the packaging for transport purposes.

Guide to the appliance

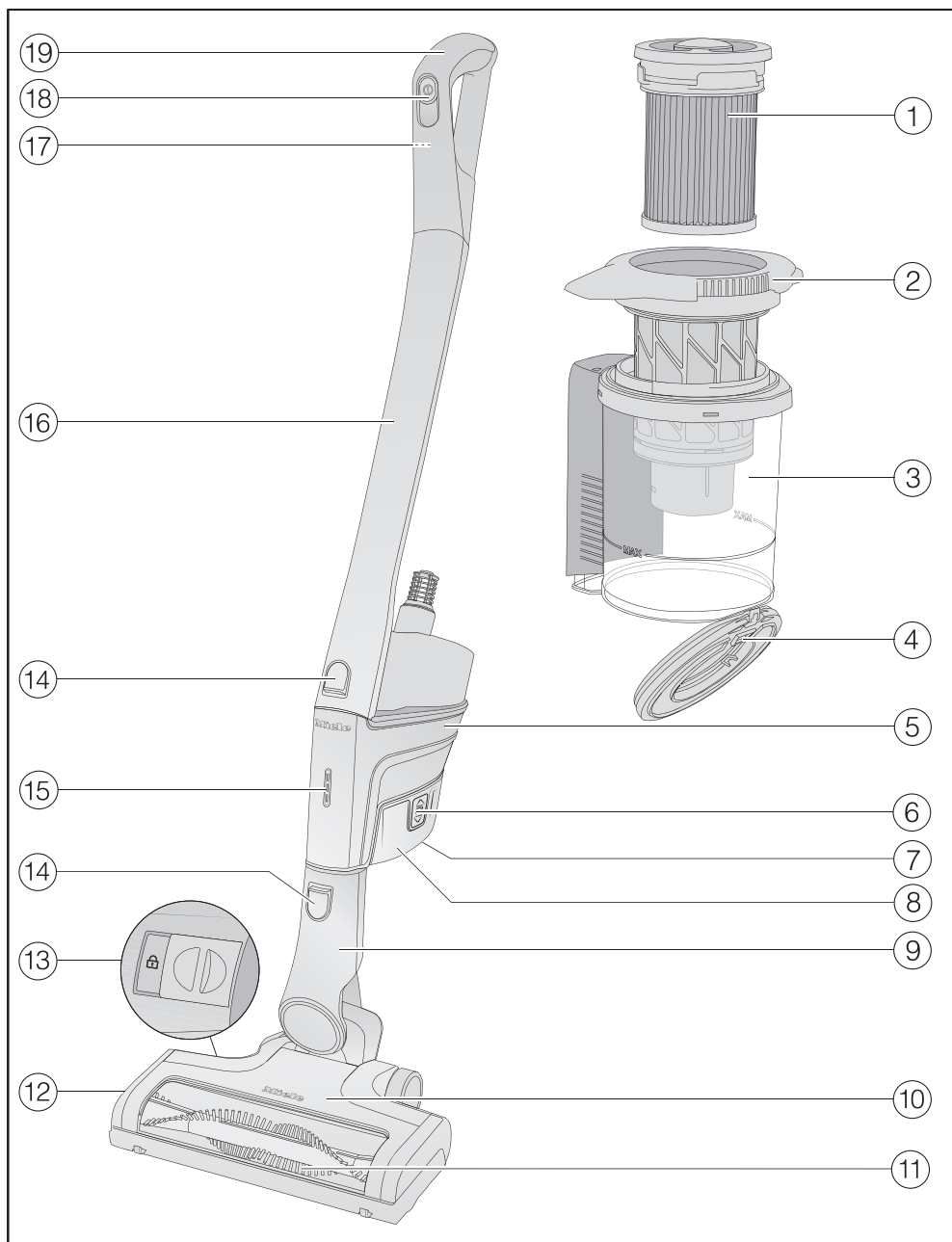

- ① Fine dust filter (HX FSF-2)
- ② Pre-filter
- ③ Dust container
- ④ Dust container flap
- ⑤ PowerUnit with a connection at the bottom for the battery, a connector at the bottom for the suction tube and Electrobrush, and a connector at the top for the suction tube and Comfort handle
- ⑥ Release catches for battery (on both sides of the battery)
- ⑦ Charging socket (at the bottom of the battery)
- ⑧ AP01 lithium-ion battery (HX LA)
- ⑨ Electrobrush connector
- ⑩ Multi Floor XXL Electrobrush (some models feature BrilliantLight lighting)
- ⑪ Removable roller brush
- ⑫ Flap
- ⑬ Release catch for opening the Electrobrush
- ⑭ Release catches
- ⑮ Battery charging state indicator
- ⑯ Suction tube
- ⑰ Release catch for Comfort handle (on the back)
- ⑱ On/Off switch with suction power selector
- ⑲ Comfort handle

Caring for the environment

Disposing of the packaging material

The packaging material is used for handling and protects the appliance from transport damage. The packaging material used is selected from materials which are environmentally friendly for disposal and can generally be recycled.

Recycling the packaging material reduces the use of raw materials. Use material-specific collection points for valuable materials and take advantage of return options.

We recommend you keep the packaging material for transport purposes.

Disposing of your old appliance

Before disposing of your old appliance, remove the fine dust filter and dispose of it with your household waste.

Electrical and electronic appliances contain many valuable materials. They also contain certain materials, compounds and components which were essential for their correct functioning and safety. These could be hazardous to human health and to the environment if disposed of with household waste or if handled incorrectly. Please do not, therefore, dispose of your old appliance with household waste.



Instead, please make use of officially designated collection and disposal points to dispose of and recycle electrical and electronic appliances in your local community, with your dealer or with Miele, free of charge. By law, you are solely responsible for deleting any personal data from the old appliance prior to disposal. You are legally obliged to remove any old batteries which are not securely enclosed by the appliance and to remove any lamps without destroying them, where this is possible. These must be taken to a suitable collection point where they can be handed in free of charge. Please ensure that your old appliance poses no risk to children while being stored for disposal.

Disposing of old batteries

In many cases, electrical and electronic appliances contain batteries which must not be disposed of with household waste after use. You are legally obliged to remove any old batteries which are not securely enclosed by the appliance and take them to a suitable collection point (e.g. retailer) where they can be handed in free of charge. Insulate the metal contacts with adhesive tape to prevent short circuits. Batteries may contain substances which can be hazardous to human health and the environment.

The labelling on the battery will provide further information. For example, batteries containing lithium are marked “Li-ion”. The bin symbol with a cross through it means that the batteries must not be disposed of in household waste. We are also required to inform you that a bin with a cross through it which also has one or more chemical symbols on it indicates that the battery contains lead (Pb), cadmium (Cd) and/or mercury (Hg).



Old batteries contain valuable raw materials which can be recycled. Disposing of batteries separately makes them easier to handle and recycle.

Installation and connection

Assembling the vacuum cleaner

You can assemble the vacuum cleaner in 2 different ways.

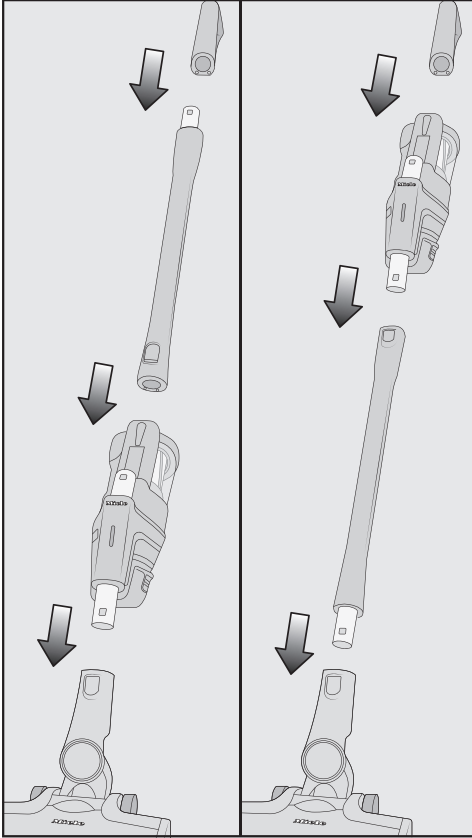

- You can place the suction tube either above or below the PowerUnit.

Take care to assemble the vacuum cleaner exactly as shown in the diagram.

The advantages of placing the **PowerUnit at the bottom** of the vacuum cleaner are as follows:

- Secure self-standing function possible

(see “Use – Self-standing function for short pauses in vacuuming”)

- Ergonomic (reduced strain on the wrist)
- Convenient cleaning of large surfaces

The advantages of placing the **PowerUnit at the top** of the vacuum cleaner are as follows:

- Convenient cleaning underneath furniture
- PowerUnit can be removed quickly

Using the PowerUnit solo

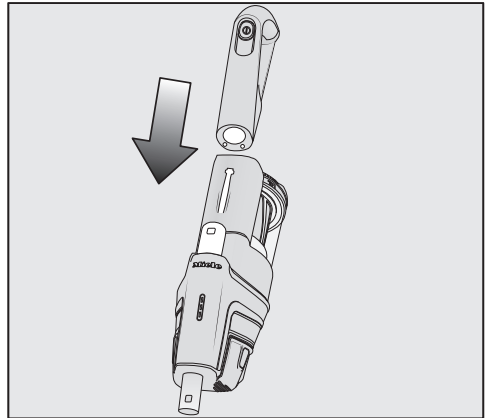

The PowerUnit can be used on its own (PowerUnit solo) without the suction tube and Electrobrush as a quick way of vacuuming up crumbs and fluff in specific areas.

Tip: This configuration is particularly suitable when using the 3-piece accessory set (see “Using the accessories supplied”).

Connecting the Comfort handle

Depending on how you decide to configure your vacuum cleaner, you can connect the Comfort handle to either the suction tube or the PowerUnit.

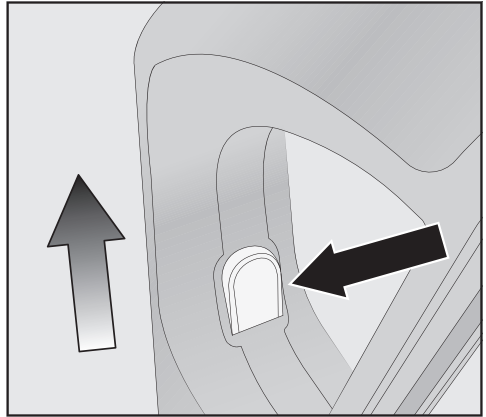
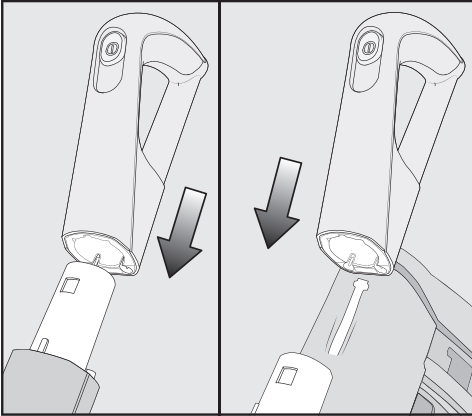

- Push the Comfort handle down onto the suction tube connector from above until it audibly clicks into place (left image detail).
 - Slide the Comfort handle along the guide line on the dust container handle and down onto the PowerUnit connector from above until it audibly clicks into place (right image detail).
 - Ensure the vacuum cleaner is switched off using the On/Off switch on the front of the Comfort handle if you want to separate the sections.
- Press the release catch and remove the Comfort handle by pulling it upwards.

Installation and connection

Connecting the PowerUnit and the suction tube

Depending on how you decide to configure your vacuum cleaner, the suction tube is located either above or below the PowerUnit.

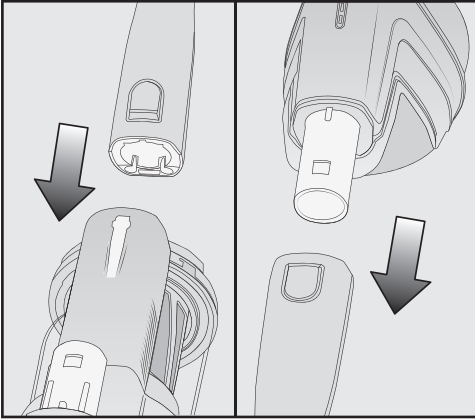

- Slide the suction tube along the guide line on the dust container handle and down onto the PowerUnit connector from above until it audibly clicks into place (left image detail).
- Push the PowerUnit connector into the suction tube from above until it audibly clicks into place (right image detail).

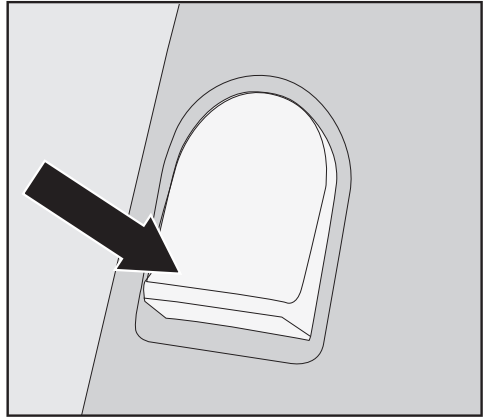

- Press the release catch to separate the individual sections from each other.

Installation and connection

Inserting the battery

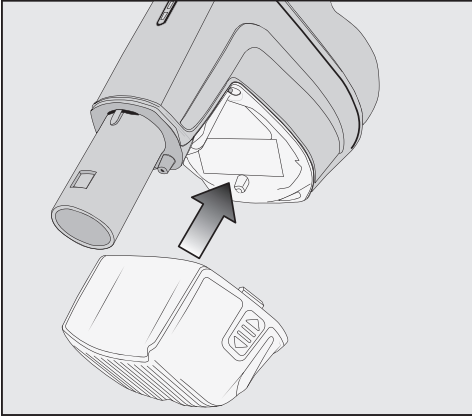

- Push the battery along the guide lines until it audibly clicks into place in the PowerUnit.

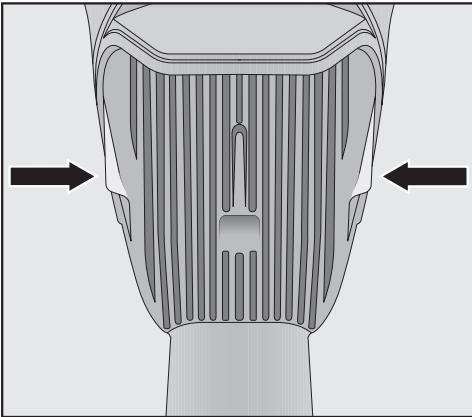

- If you want to separate the sections again, press both release catches at the side of the battery to remove the battery.

Connecting the Electrobrush

Depending on how you decide to configure your vacuum cleaner, you can connect either the PowerUnit connector or the suction tube connector to the Electrobrush.

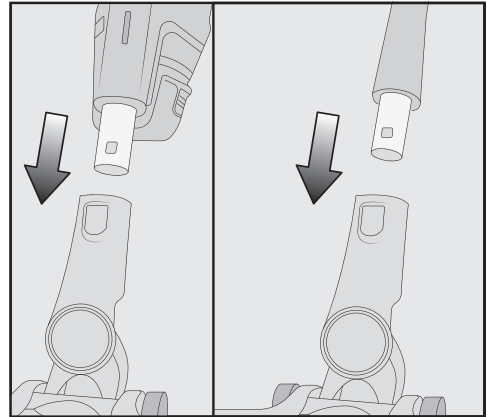

- Push the connector into the Electrobrush from above until it audibly clicks into place.

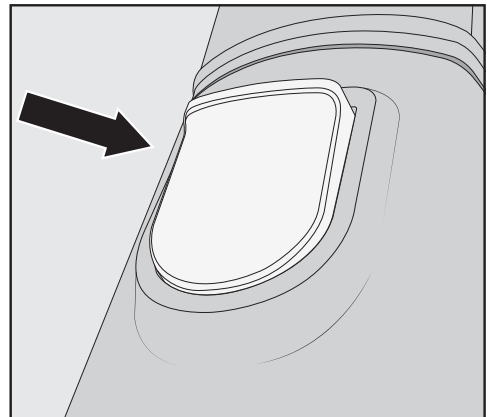

- To separate the individual sections from each other, press the release catch on the Electrobrush and pull the connector out of the Electrobrush.

Installation and connection

General battery information

The rechargeable battery is supplied not fully charged.

Charge the battery completely before using it for the first time. Allow approximately 4 hours for this.

To activate the battery, it is essential to place it in the PowerUnit when charging it for the first time.

Once the battery is fully charged, the battery charging state indicator on the PowerUnit switches off to conserve energy.

The maximum charging capacity is only achieved once the battery has been charged and run down five times.

A full charge provides enough power for 14 minutes if the vacuum cleaner is used at the maximum power level in its fully assembled state.

However, if you use the PowerUnit solo and select the minimum power level, you can vacuum for up to 60 minutes at a time.



WARNING! Keep batteries out of reach of children. Coin or button batteries containing lithium can cause severe or fatal injuries within 2 hours of being swallowed or placed inside any part of the body. Non-lithium batteries can also cause serious injuries if swallowed or placed inside any part of the body. Even flat batteries can still be dangerous. If you suspect a child has swallowed a battery or placed a battery inside any part of their body, seek medical advice immediately (Australia: Poisons Information Centre, Tel. 13 11 26; NZ: National Poisons Centre, Tel. 0800 764 766). Examine devices and make sure the battery compartment is correctly secured, e.g. that the screw or other mechanical fastener is tightened. Do not use if compartment is not secure. Used batteries must be kept away from children while awaiting disposal and must be disposed of in a safe manner.

Charging the battery (without wall mounting)

You can store the vacuum cleaner upright and charge the battery directly.

Before charging the battery for the first time, you must read the information in “Installation and connection – General battery information”.

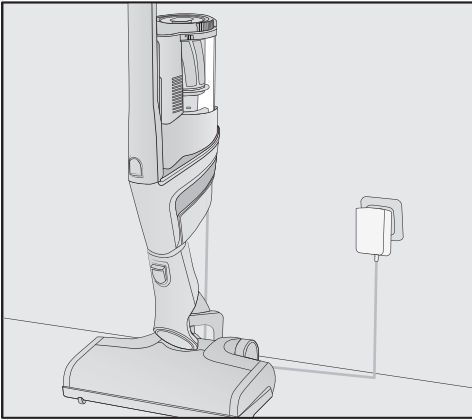

- Connect the PowerUnit to the Electrobrush to provide a secure base for the vacuum cleaner.
- Swing the vacuum cleaner forwards until the Electrobrush connector audibly clicks into place.
- Plug the supplied charging cable into the charging socket on the bottom of the battery.
- Plug the charger into a power socket.

The charging process will start.

You can read more about this in “Battery charging state indicator (while charging)”.

Charging the battery (with wall mounting)

There are 2 ways to store and charge the vacuum cleaner in the supplied wall bracket.

Before charging the battery for the first time, you must read the information in “Installation and connection – General battery information”.

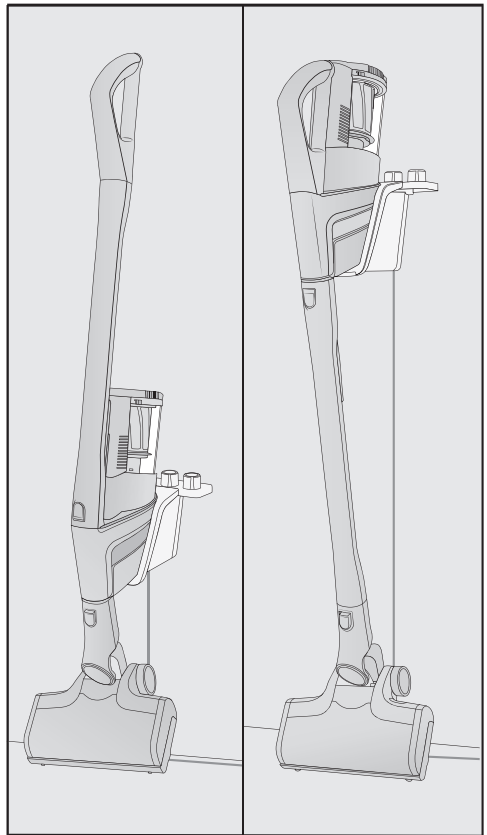

You will need a suitable location near a free power socket for mounting the appliance on the wall.

Installation and connection

Wall mounting

The supplied wall bracket has a mounting plate with a bag of screws attached to the back.

Attach the mounting plate to the point on the wall where you want the wall mounting to be.

- Remove the bag of screws.

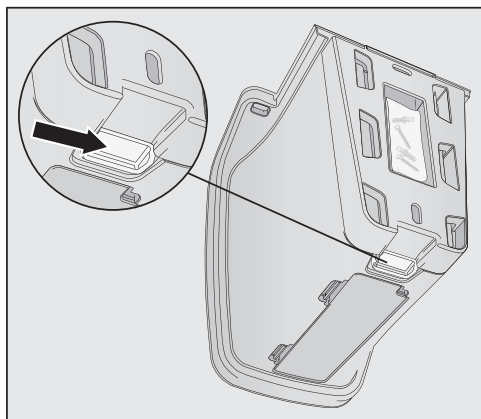

- Press the release catch at the bottom of the wall bracket.

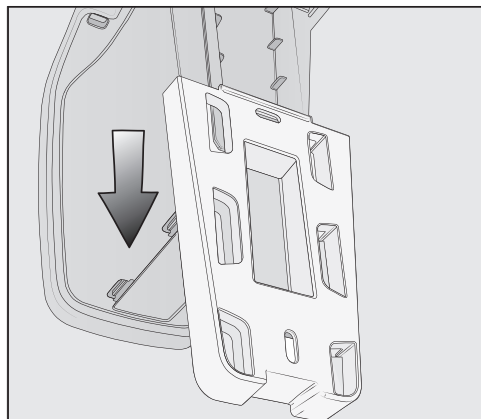

- Remove the mounting plate from the wall bracket by sliding it downwards.

Attaching the mounting plate

2 plugs and 2 T20 TORX screws are supplied for attaching the mounting plate to the wall.

You will also need a battery-operated screwdriver or a drill (with a drilling diameter of 6 mm).

Depending on how you decide to configure your vacuum cleaner, select a distance of 45 cm or 98 cm between the bottom edge of the mounting plate and the floor.

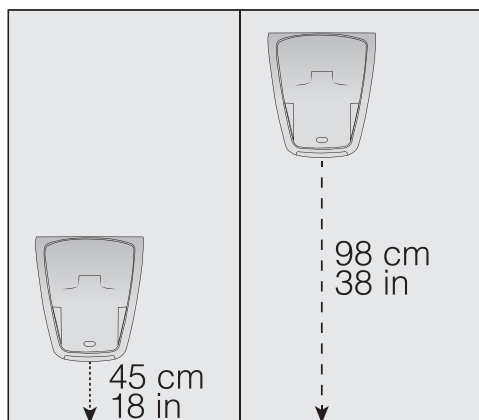

Be careful not to damage any cables laid in the wall.

Installation and connection

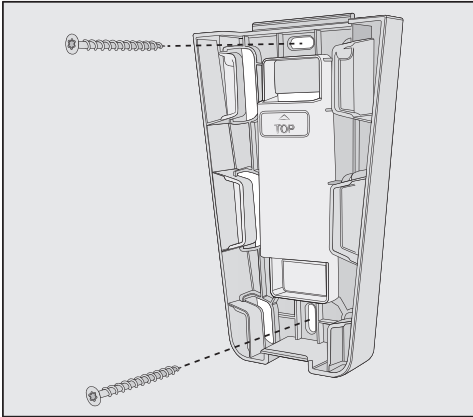

- Attach the mounting plate to the wall.

Attaching the charging cable to the wall bracket

A cable compartment is located on the underside of the wall bracket.

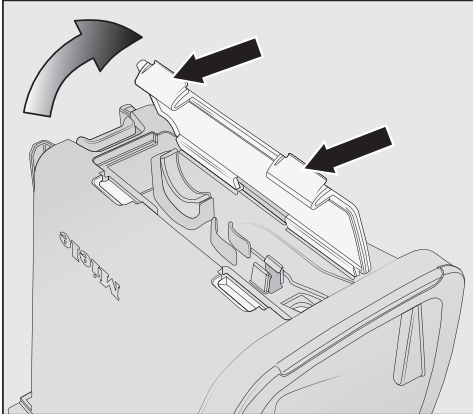

- Press both release catches on the underside of the wall bracket and remove the cable compartment cover.

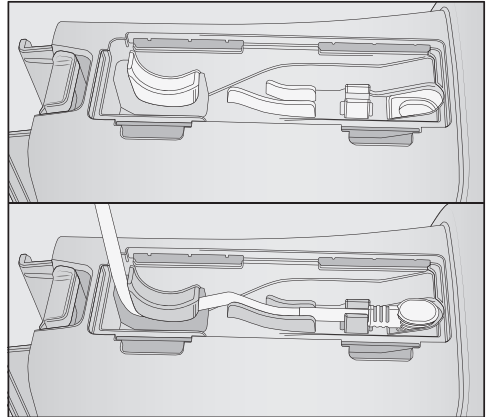

- Plug the supplied charging cable into the opening from above.
- Lay the charging cable in its guide.

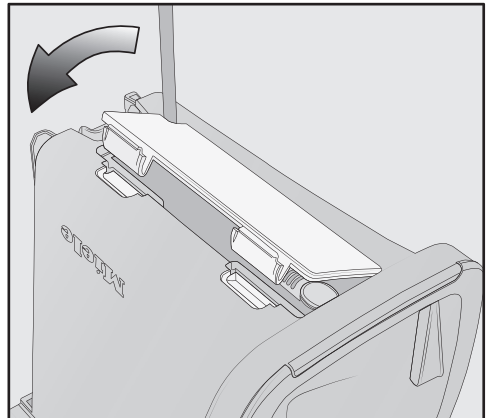

- Refit the cover and lock the cable compartment.
- Then turn over the wall bracket.

Installation and connection

Connecting the accessories holder (if required)

An accessories holder is supplied for storing the 3-piece accessory set on the wall bracket (see “Using the accessories supplied”).

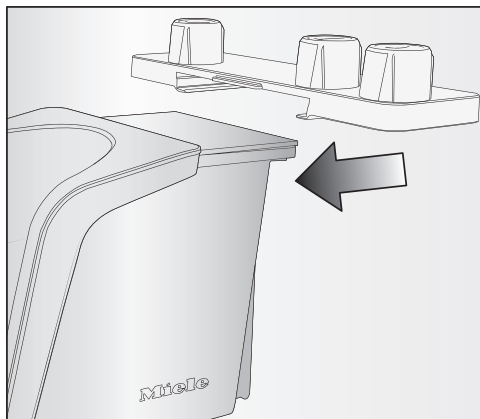

- Push the accessories holder onto the wall bracket as far as it will go.

Connecting the wall bracket

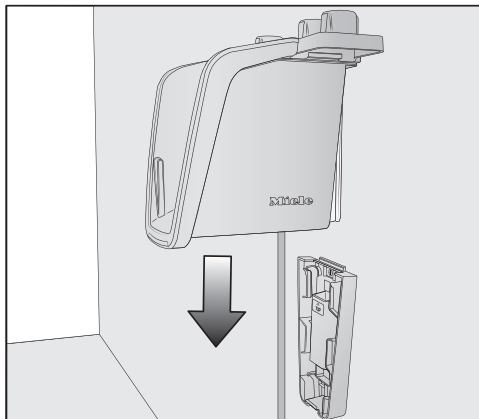

- Slide the wall bracket down into the mounting plate from above until it audibly clicks into place.

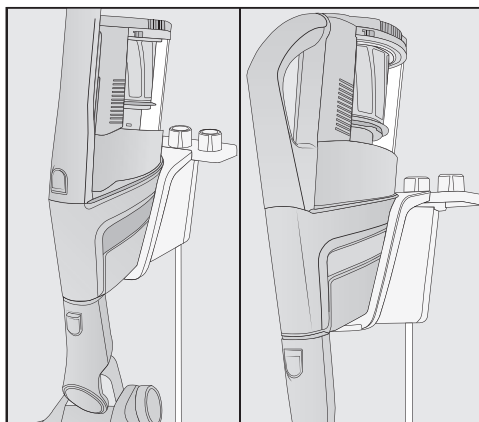

- Slide the PowerUnit of the fully assembled vacuum cleaner, with the battery inserted, down into the wall bracket from above.
- Plug the charger into the power socket.

The charging process will start.

Battery charging state indicator (while charging)

The battery charging state is displayed on the PowerUnit.

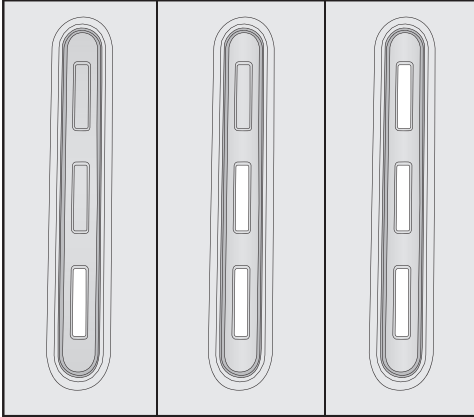

Charging capacity	Display
Approx. 0–34 %	Bottom light flashes slowly
Approx. 35–69 %	Bottom light is lit up; middle light flashes slowly
Approx. 70–90 %	Bottom and middle lights are lit up; top light flashes slowly
Approx. 91–99 %	Bottom, middle and top lights are lit up
100 %	Display switches off

Once the battery is fully charged, the battery charging state indicator switches off to conserve energy.

If the battery has not been used for a long time and has run down, it will go into safe mode. As a result, the battery charging state indicator will only respond after approximately 30–60 minutes when charging in the PowerUnit.

Battery charging state indicator (while in use)

The battery charging state is displayed on the PowerUnit.

Charging capacity	Display
Approx. 100–70 %	Top, middle and bottom lights are lit up
Approx. 69–35 %	Middle and bottom lights are lit up
Approx. 34–15 %	Bottom light is lit up
Approx. 14–0 %	Bottom light flashes slowly

We recommend allowing the battery to run down completely before recharging it. In this way, you will benefit from the battery's full capacity.

Using the supplied accessories

Miele offers a range of suitable accessories for many special applications (see “Optional accessories”).

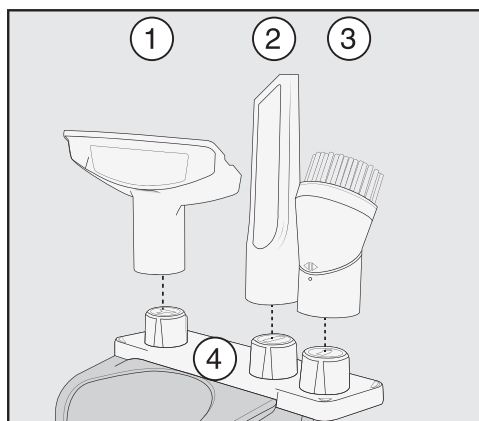

- ① **Upholstery nozzle XL**
Accessory for cleaning upholstery, mattresses and cushions
- ② **Crevice nozzle**
Accessory for cleaning in folds, crevices or corners
- ③ **Dusting brush**
Accessory for vacuuming skirting boards, carved furniture or ornaments.
The head can be swivelled to adjust the angle.
- ④ **Accessories holder for wall bracket**
For storing the 3-piece accessory set

Symbols on the holder show where to attach the different accessories. You can fit the accessories holder to the wall bracket (see “Installation and connection – Connecting the accessories holder”).

Accessories holder for the suction tube

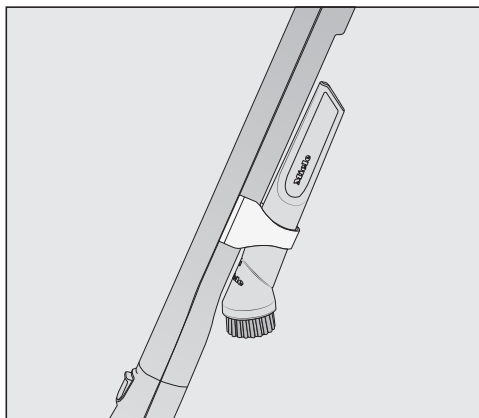

This accessories holder allows you to carry around 2 accessories from the 3-piece accessory set while you vacuum.

Using the supplied accessories

Multi Floor XXL Electrobrush

Follow the flooring manufacturer's cleaning and care instructions.

 Damage caused by trapped material.

Risk of the flooring getting scratched.

Make sure that there is no coarse dirt or debris trapped in the bottom of the Electrobrush, e.g. shards or stones.

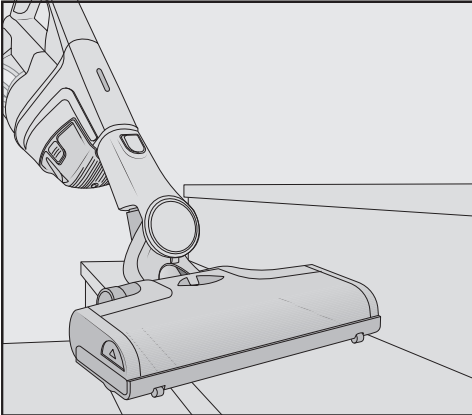

When fitted with the red roller brush (fitted as standard), the Electrobrush can be used for daily cleaning of carpets, rugs and hard floors.

For optimum cleaning results on ordinary carpets and rugs, use this red roller brush.

When cleaning delicate carpets and rugs, we recommend using the grey Carpet Care roller brush supplied.

Tip: The suction tube is not a convenient option for cleaning carpeted stairs.

Tip: If you ever need to vacuum up substantial amounts of coarse dirt or debris, use the PowerUnit solo (see “Installation and connection – Using the PowerUnit solo”).

Carpet Care roller brush

Follow the flooring manufacturer's cleaning and care instructions.

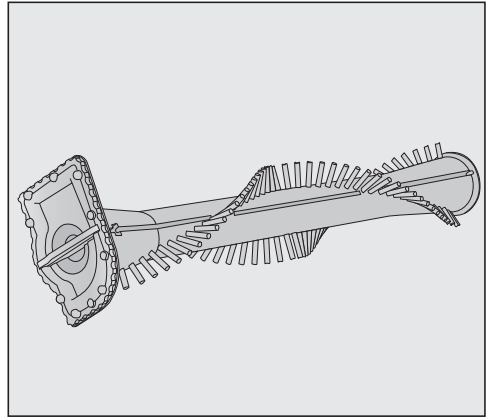

When fitted with this grey roller brush, the Electrobrush can be used to clean delicate carpets and rugs.

Insert the Carpet Care roller brush into the Electrobrush instead of the roller brush fitted as standard.

Using the supplied accessories

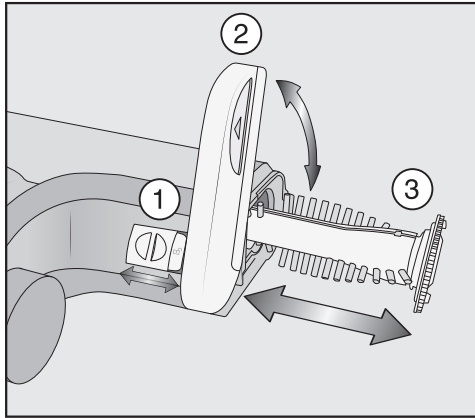

- Unlock the cover on the side of the Electrobrush so that the  symbol becomes visible ①.
- Lift the cover up as far as it will go ②.
- Remove the roller brush that has been fitted as standard ③.
- Insert the Carpet Care roller brush.
- Close and lock the cover.

Hardfloor Care soft roller (HX HC)

(depending on model)

Follow the flooring manufacturer's cleaning and care instructions.

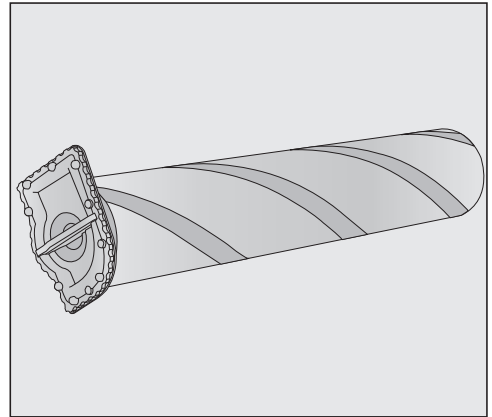

When fitted with the Hardfloor Care soft brush, the Electrobrush can be used to clean delicate hard floors.

Insert the Hardfloor Care soft brush into the Electrobrush instead of the roller brush fitted as standard (see “Carpet Care roller brush” above).

When you use the Hardfloor Care soft roller, the Electrobrush power consumption is automatically set to the optimum level – this can lead to a change in the operating noise.

Using the supplied accessories

Electro Compact handheld brush (HX SEB)

(depending on model)

Follow the flooring manufacturer's cleaning and care instructions.

 Damage caused by trapped material.

Risk of the flooring getting scratched.

Make sure that there is no coarse dirt or debris trapped in the bottom of the handheld brush, e.g. shards or stones.

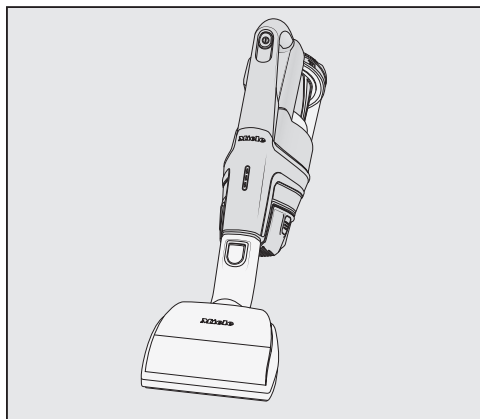

The handheld brush is particularly suitable for intensive cleaning of car seats and carpeted stairs.

For optimum cleaning results on upholstery, use the upholstery nozzle XL.

Tip: The suction tube is not a convenient option for cleaning car seats or stairs.

Tip: If you ever need to vacuum up substantial amounts of coarse dirt or debris, use the PowerUnit solo (see "Installation and connection – Using the PowerUnit solo").

Additional battery (HX LA)

(depending on model)

Using the additional battery doubles the amount of time the vacuum cleaner can be used for.

Before charging for the first time, you must read the information in "Installation and connection – General battery information".

Using the supplied accessories

Battery charger cradle (HX LS)

(depending on model)

Before charging for the first time, you must read the information in “Installation and connection – General battery information”.

When charging the battery for the first time, you must use the PowerUnit. As of the second charging operation, you can use the battery charger cradle instead.

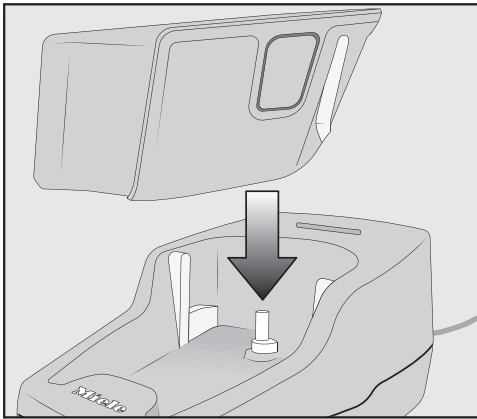

- Push the battery into the charger cradle until it audibly clicks into place.
- Insert the plug into a power socket.

The charging process will start. The battery charging state indicator flashes on the left.

You can find out more about the battery charging state indicator in “Installation and connection – Battery charging state indicator”.

If you place the run-down battery in the charger cradle straight after use, it will only start charging once the battery has cooled down.

The cooling process can take up to 60 minutes. The battery charging state indicator on the charger cradle will not respond during this time.

Switching on and off

- If you have charged the battery in the wall bracket, take the vacuum cleaner out of the wall bracket.
- If you have charged the battery directly, unplug the charger from the charging socket on the bottom of the battery.

For the best possible cleaning results, always activate the ComfortClean function before switching on the vacuum cleaner (see “Maintenance – Activating the ComfortClean function”).

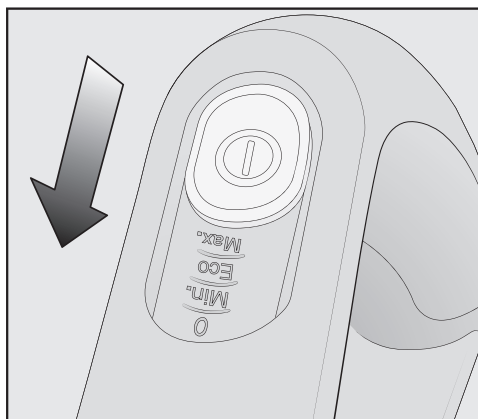

- Press the On/Off switch on the Comfort handle ①.

Selecting the suction power level

The suction power level can be adjusted for the specific situation. Reducing the suction power reduces the amount of effort required to manoeuvre the Electrobrush.

There are 3 power levels to choose from on the Comfort handle:

Min.	Lowest power level for light soiling
Eco	Medium power level for normal soiling
Max.	Highest power level for heavy soiling

The floor covering detection function is activated at every power level. The Electrobrush power consumption is automatically set to the optimum level based on the type of flooring and roller brush used – this can lead to a change in the operating noise.

Carpet protective function

When the vacuum is at a standstill, the power of the Electrobrush is reduced automatically after a few seconds, to protect the floor surface.

Use

Illuminating the work area

(depending on model)

The Electrobrush on your vacuum cleaner is equipped with BrilliantLight to illuminate the work area.

Self-standing function for short pauses in vacuuming

(For safety reasons, this function can only be used when the PowerUnit is fitted at the bottom of the vacuum cleaner)

If you are vacuuming with the PowerUnit fitted at the bottom of the vacuum cleaner, you can easily interrupt operation while the appliance is switched on.

- Swing the vacuum cleaner forwards until the Electrobrush connector audibly clicks into place.

The vacuum cleaner stays securely upright, the Electrobrush switches itself off and the battery is conserved.

If you then unlock the connector on the Electrobrush, the Electrobrush will switch on again.

 Risk of injury caused by rotating roller brush.

You can injure yourself on the rotating roller brush.

Switch the vacuum cleaner off before doing any maintenance work. Use the On/Off switch on the Comfort handle to do this.

We recommend using only genuine Miele accessories bearing the “ORIGINAL Miele” logo on the packaging. Only these will guarantee the optimum performance of your vacuum cleaner and the best possible cleaning results.

Please note that faults and damage caused by use of accessories which do not bear the “ORIGINAL Miele” logo on the packaging are not covered by the vacuum cleaner warranty.

Purchasing accessories

Original Miele accessories are available from the Miele webshop, the Miele Customer Service Department and from your Miele dealer.

Original Miele accessories are identified by the “ORIGINAL Miele” logo on the packaging.



With 3D4U, Miele also offers free accessories to download for your 3D printer (www.miele.com, Service, 3D4U).

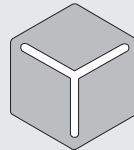

3 D 4 U

Maintenance

Filter system

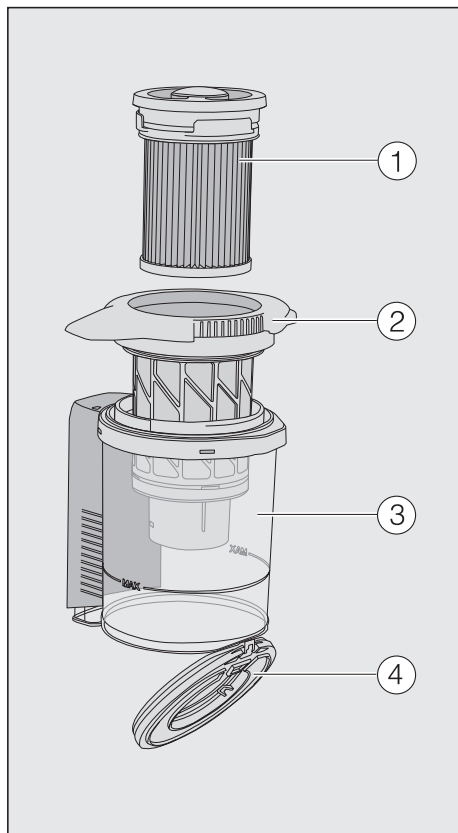

- ① Fine dust filter (HX FSF-2)
- ② Pre-filter
- ③ Dust container
- ④ Dust container flap

Activating the ComfortClean function

Always run the interim cleaning function for the fine dust filter before emptying the dust container. You should also run it whenever the suction power begins to drop.

This enables the vacuum cleaner to achieve the very best cleaning performance again straight away.

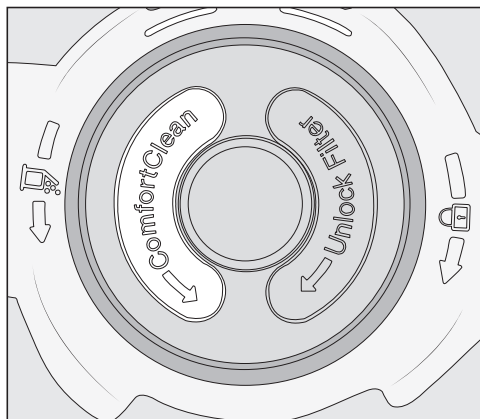

- The fine dust filter is located in the lid of the dust container. Twist it anti-clockwise by 3 180° turns. Use the recesses to help you.

You will hear an operating noise, which is a normal part of how the ComfortClean function works.

Emptying the dust container

Empty the dust container at the latest when the dust has reached the **MAX** marking on the dust container.

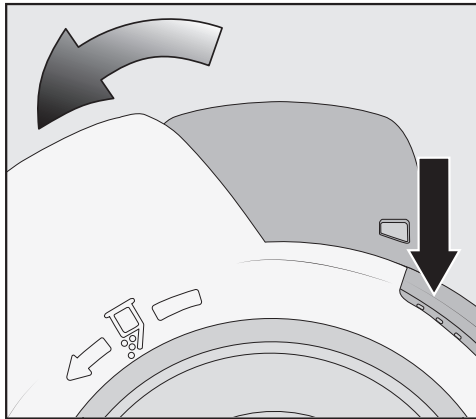

- Turn the lid of the dust container in the direction of the arrow as far as the first stop. Use the grey gripping surfaces to help you do this.

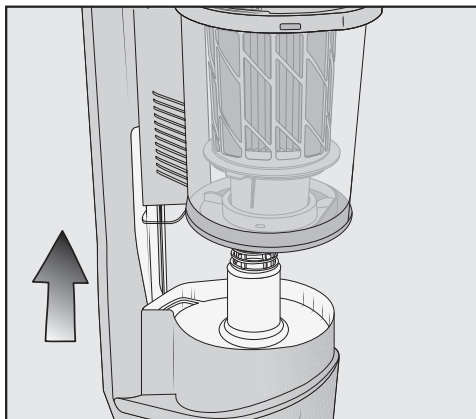

- Lift the dust container upwards to remove it.

Provided that no prohibited substances are present, the contents of the dust container can be disposed of with normal household waste.

- Hold the dust container close to the bin to prevent dust from billowing out.

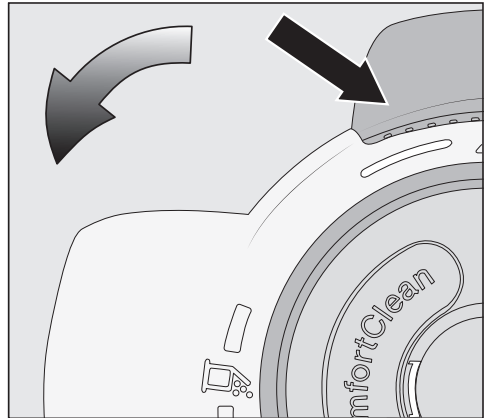

- Turn the lid of the dust container in the direction of the arrow as far as the next stop. Use the grey gripping surfaces to help you do this.

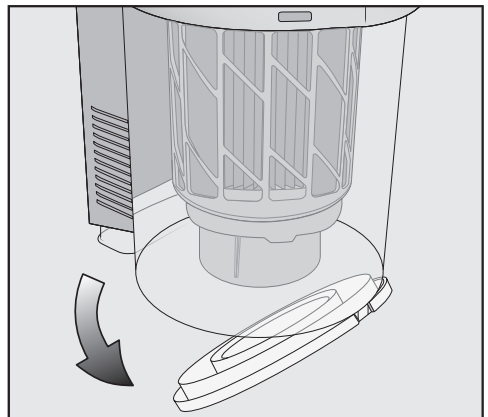

The dust container flap will open and the dust will fall out.

Maintenance

If chunks of dust, hair or coarse debris do not fall out, remove the pre-filter by pulling it upwards (see “Cleaning the pre-filter and fine dust filter” below).

- Turn the lid of the dust container back to its original position.
- Close the dust container flap, making sure it clicks into place.

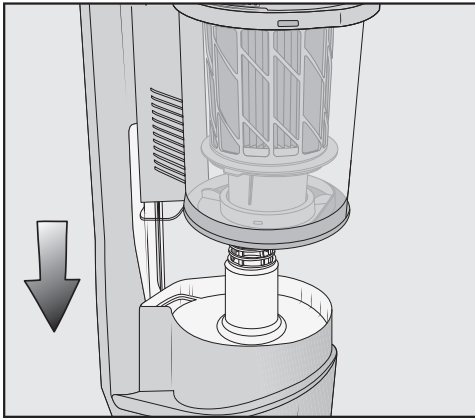

- Slide the dust container handle along the guide line and down onto the PowerUnit connector from above until the dust container audibly clicks into place.

Cleaning the pre-filter and fine dust filter

Clean both filters thoroughly at least once every 3 months.

When cleaning them, it is essential to follow the steps in the order described.

- Remove the dust container.
- Empty the dust container over a bin.

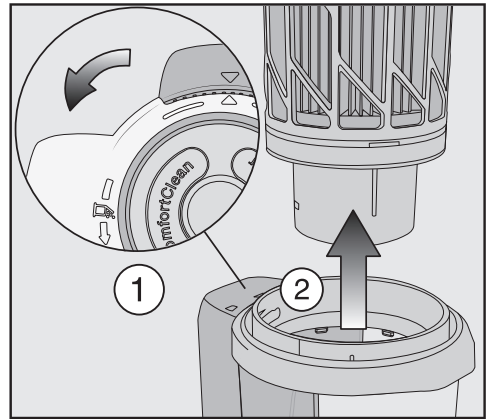

- Turn the lid of the dust container beyond the stop until the arrow tips are aligned at the top ①.
- Remove the pre-filter by pulling it upwards ②.

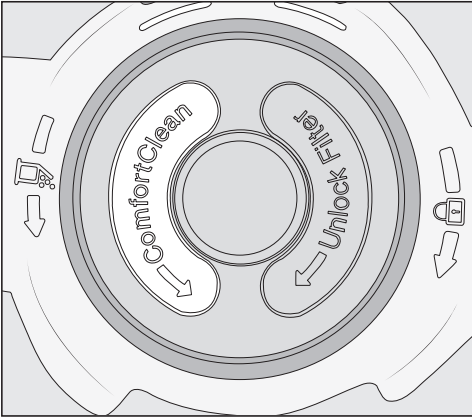

- Twist the fine dust filter anti-clockwise by 10 180° turns. Use the recesses to help you.

You will hear an operating noise, which is a normal part of how the Comfort-Clean function works.

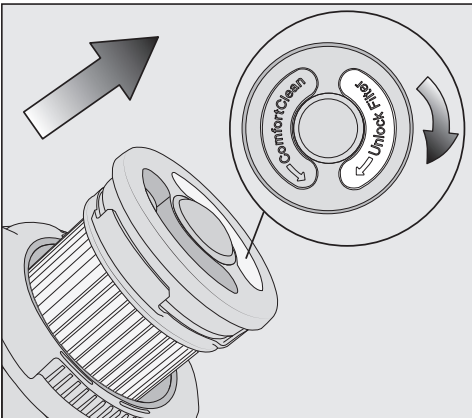

- Twist the fine dust filter clockwise. Use the recesses to help you.
- Remove the fine dust filter.

⚠ Risk of damage caused by incorrect cleaning.

The fine dust filter can become damaged and be less effective as a result.

Do not clean the fine dust filter with water and avoid cleaning the inside. Do not use pointed or sharp-edged objects to clean the filter. Do not brush the fine dust filter.

- Hold the fine dust filter over a bin.
- Empty the fine dust filter by carefully tapping the rubberised lower edge.
- Turn the fine dust filter slightly while you do this to free the dirt from all of the crevices.

⚠ Risk of damage caused by incorrect cleaning.

The pre-filter can become damaged and be less effective as a result.

Do not clean the pre-filter with water. Do not use pointed or sharp-edged objects to clean the filter.

- Clean the pre-filter with the dusting brush supplied or with a dry cloth.
- After cleaning the fine dust filter and pre-filter, reinsert the former into the latter by pressing the round cap on top of the fine dust filter down as far as it will go.

To continue achieving the best possible cleaning results, replace the fine dust filter (HX FSF-2) with a new one after approx. 3 years.

Maintenance

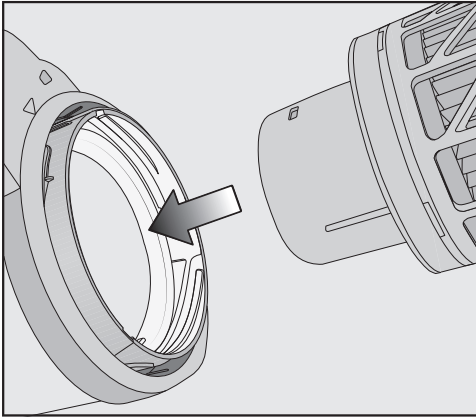

- Reinsert the pre-filter in the dust container.

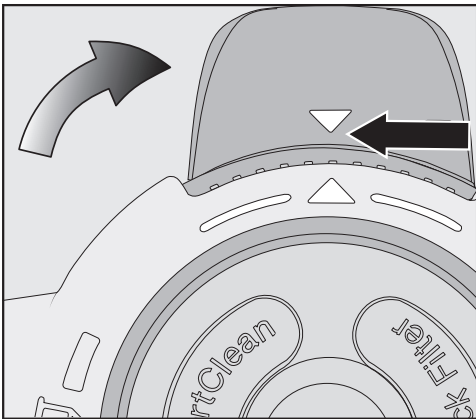

- To do this, line up the guides (arrows) and turn the pre-filter back to its original position.
- Close the dust container flap, making sure it clicks into place.
- Reattach the dust container to the PowerUnit connector.

Cleaning the dust container

Clean the dust container as required.

- Remove the dust container.
- Empty the dust container over a bin and lift the pre-filter upwards to remove it.
- Clean the dust container using water and mild washing-up liquid.
- Dry the dust container thoroughly.
- Reinsert the pre-filter in the dust container and turn the pre-filter back to its original position.
- Reattach the dust container to the PowerUnit connector.

Cleaning the Electrobrush/ handheld brush

(The availability of the handheld brush depends on the model)

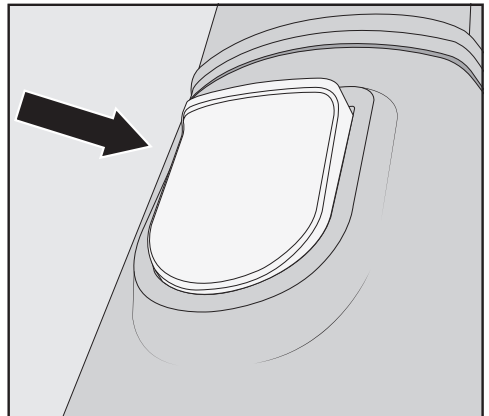

- Disconnect the Electrobrush/handheld brush from the vacuum cleaner.
- Place the Electrobrush/handheld brush upside down on a level, clean surface.

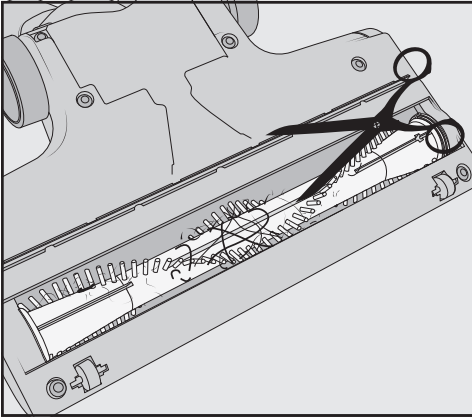

- Cut any threads or hairs that have wound themselves around the roller brush with a pair of scissors. To guide the scissors, move along the guide track on the roller brush.

Then run the vacuum cleaner to vacuum up the cut threads and hairs.

If the small running wheels are very heavily soiled or blocked, you can remove them for easier cleaning (not necessary in the case of the handheld brush). To remove them, use a flat-head screwdriver.

Removing the roller brush from the Electrobrush

(Not possible with the handheld brush)

You can take the roller brush out of the Electrobrush in order to remove stubborn soiling and clean the inside of the Electrobrush.

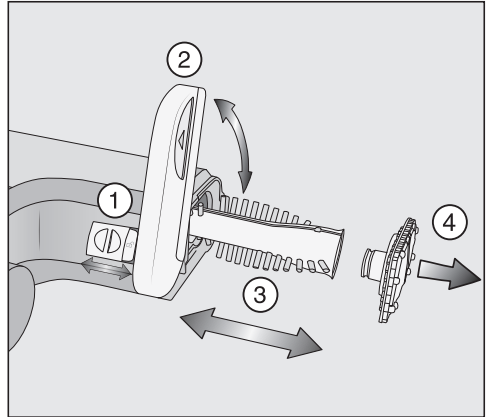

- Unlock the cover on the side of the Electrobrush so that the  symbol becomes visible ①.
- Lift the cover up as far as it will go ②.
- Remove the roller brush ③.
- Remove the roller brush handle if you identify heavy soiling there ④.
- Clean the roller brush and the roller brush handle, and remove any stubborn soiling inside the Electrobrush.
- Reassemble the Electrobrush in reverse order.

Replacing the rechargeable battery

An original Miele AP01 lithium-ion rechargeable battery (HX LA) is required.

Follow the instructions regarding the handling and disposal of rechargeable batteries found in the following sections: “Warning and safety”, “Caring for the environment” and “Installation and connection - General battery information”).

Error messages



Risk of injury caused by rotating roller brush.

You can injure yourself on the rotating roller brush.

Switch the vacuum cleaner off before dealing with any problems. Use the On/Off switch on the Comfort handle to do this.

Error messages are displayed with a quick flashing light on the battery charging state indicator on the PowerUnit.

Problem	Cause and remedy
Top indicator is flashing quickly	<p>“Comfort handle not recognised” error</p> <ul style="list-style-type: none"> ■ Remove the Comfort handle and reconnect it (see “Installation and connection – Connecting the Comfort handle”). ■ Remove the battery, wait for 10 seconds and reinsert it.
Middle indicator is flashing quickly	<p>“Motor overheating” error</p> <ul style="list-style-type: none"> ■ Empty and clean the dust container, pre-filter and fine dust filter (see “Maintenance”). ■ Remove the battery, wait for 10 seconds and reinsert it. ■ Wait for approximately 30 minutes before switching the vacuum cleaner back on again.
Middle and top indicators are flashing quickly	<p>“Jammed roller brush” error</p> <ul style="list-style-type: none"> ■ Insert the grey Carpet Care roller brush instead of the red roller brush fitted as standard (see “Using the accessories supplied – Carpet Care roller brush”). ■ Select a lower power level (see “Use – Selecting the suction power level”).
Bottom and top indicators are flashing quickly	<p>Internal system error</p> <ul style="list-style-type: none"> ■ Remove the battery, wait for 10 seconds, reinsert it and charge it.
Bottom and middle indicators are flashing quickly	<p>“Battery overheating” or “Battery not recognised” error</p> <ul style="list-style-type: none"> ■ Wait for approximately 30 minutes before switching the vacuum cleaner back on again. ■ Insert an original Miele AP01 lithium-ion rechargeable battery (HX LA).

Problem solving guide

With the help of the following guide, minor faults in the performance of the appliance, some of which may result from incorrect operation, can be remedied without contacting Miele. This will save you time and money because you won't need a service call.

Please note that a call-out charge will be applied to unnecessary service visits where the problem could have been rectified as described in these operating instructions.



Risk of injury caused by rotating roller brush.

You can injure yourself on the rotating roller brush.

Switch the vacuum cleaner off before dealing with any problems. Use the On/Off switch on the Comfort handle to do this.

Problem	Cause and remedy
The vacuum cleaner does not start when it is switched on.	There is no battery inserted or the battery has been inserted incorrectly. <ul style="list-style-type: none"> ■ Insert the battery or check how the battery is positioned (see “Installation and connection – Inserting the battery”).
	The rechargeable battery is not sufficiently charged. <ul style="list-style-type: none"> ■ Charge the battery exactly as described in these operating instructions (see “Installation and connection – General battery information” and “Charging the battery”).
	An original Miele battery has not been inserted. <ul style="list-style-type: none"> ■ Insert an original Miele AP01 lithium-ion rechargeable battery (HX LA).
	The battery was not placed in the PowerUnit when charging it for the first time. <ul style="list-style-type: none"> ■ To activate the battery, it must be placed in the PowerUnit the first time it is charged (see “Installation and connection – General battery information” and “Charging the battery”).
	The charger is still plugged in. <ul style="list-style-type: none"> ■ Pull the plug out of the charging socket on the bottom of the battery.

Problem solving guide

Problem	Cause and remedy
<p>The operating noise is changing during vacuuming.</p>	<p>The Electrobrush power consumption is automatically set to the optimum level based on the type of flooring and roller brush used.</p> <ul style="list-style-type: none"> ■ The noise is not unusual – the vacuum cleaner is functioning normally.
<p>The Electrobrush switches itself off.</p>	<p>The Electrobrush is overloaded – this can happen on surfaces like deep-pile carpet.</p> <ul style="list-style-type: none"> ■ Switch the vacuum cleaner off and switch it on again at a reduced suction power level. Use the On/Off switch on the Comfort handle to do this.
<p>The roller brush is not rotating.</p>	<p>The roller brush that has been fitted is not the ideal choice for the type of flooring.</p> <ul style="list-style-type: none"> ■ Select a lower power level (see “Use – Selecting the suction power level”). ■ Insert the grey Carpet Care roller brush (see “Using the accessories supplied – Carpet Care roller brush”). <p>The roller brush is dirty.</p> <ul style="list-style-type: none"> ■ Clean the roller brush (see “Maintenance – Cleaning the Electrobrush” and “Removing the roller brush from the Electrobrush”).
<p>Cleaning performance is reduced.</p>	<p>The fine dust filter/pre-filter is soiled.</p> <ul style="list-style-type: none"> ■ Run the interim cleaning function for the fine dust filter (see “Maintenance – Activating the Comfort-Clean function”). ■ Clean both filters thoroughly (see “Maintenance – Cleaning the pre-filter and fine dust filter”). <p>The fine dust filter is worn.</p> <ul style="list-style-type: none"> ■ Insert a new fine dust filter (HX FSF-2).
<p>The cleaning performance is poor.</p>	<p>The dust container is full.</p> <ul style="list-style-type: none"> ■ Empty and clean the dust container (see “Maintenance”). <p>The Electrobrush is dirty/blocked.</p> <ul style="list-style-type: none"> ■ Clean the Electrobrush (see “Maintenance – Cleaning the Electrobrush” and “Removing the roller brush from the Electrobrush”).

Problem solving guide

Problem	Cause and remedy
The vacuum cleaner keeps falling over.	<p>You have configured the vacuum cleaner with the PowerUnit at the top.</p> <ul style="list-style-type: none">■ Reassemble the vacuum cleaner so that it is configured with the PowerUnit at the bottom (see “Installation and connection – Assembling the vacuum cleaner”).

Service

Contact in case of malfunction

In the event of any faults which you cannot remedy yourself, please contact Miele.

Contact information for Miele can be found at the end of this document.

Please note that telephone calls may be monitored and recorded for training purposes and that a call-out charge will be applied to service visits where the problem could have been resolved as described in this booklet.

Warranty

The manufacturer's warranty for this appliance is 2 years.

For more information about country specific warranty terms and conditions, please contact Miele.

 Risk of injury caused by rotating roller brush.

You can injure yourself on the rotating roller brush.

Always switch the vacuum cleaner off before cleaning it. Use the On/Off switch on the Comfort handle to do this.

Vacuum cleaner and accessories

 Risk of electric shock from mains voltage.

If moisture gets into the charger, there is a risk of electric shock.

Do not let the charger get wet.

Follow the special cleaning instructions for the dust container in the “Maintenance” section.

The exterior plastic surfaces of the vacuum cleaner and all plastic accessories should be cleaned with a commercially available cleaner suitable for plastic. Ensure the water or cleaner does not reach the internal parts of the vacuum cleaner.

 Damage due to unsuitable cleaning agents.

All surfaces are susceptible to scratching. Contact with unsuitable cleaning agents can alter or discolour all surfaces.

Do not use abrasive cleaning agents, glass cleaning agents, all-purpose cleaners or oil-based care products.

Optional accessories

Follow the flooring manufacturer's cleaning and care instructions.

We recommend using only genuine Miele accessories bearing the "ORIGINAL Miele" logo on the packaging. Only these will guarantee the optimum performance of your vacuum cleaner and the best possible cleaning results.

Please note that faults and damage caused by use of accessories which do not bear the "ORIGINAL Miele" logo on the packaging are not covered by the vacuum cleaner warranty.

Purchasing accessories

Original Miele accessories are available from the Miele webshop, the Miele Customer Service Department and from your Miele dealer.

Original Miele accessories are identified by the "ORIGINAL Miele" logo on the packaging.



With 3D4U, Miele also offers free accessories to download for your 3D printer (www.miele.com, Service, 3D4U).

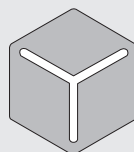

3 D 4 U

Certain models are supplied with one or more of the following accessories as standard.

Electro Compact handheld brush (HX SEB)

For intensive cleaning of car seats and carpeted stairs.

Hardfloor Care soft roller (HX HC)

For cleaning delicate hard floors.

Radiator brush (SHB 30)

For dusting radiators, narrow shelves and crevices.

Mattress nozzle (SMD 10)

For vacuuming upholstery, mattresses, cushions, curtains, covers etc.

Crevice nozzle, 300 mm (SFD 10)

Extra long crevice nozzle for cleaning in folds, crevices and corners.

Crevice nozzle, 560 mm (SFD 20)

Flexible crevice nozzle for vacuuming hard to reach places.

AP01 additional battery (HX LA)

For doubling the amount of time the vacuum cleaner can be used for.

Before charging for the first time, you must read the information in “Installation and connection – General battery information”.

LS03 charger cradle (HX LS)

For charging the additional battery independently of the appliance, i.e. while the appliance is in use.

Before charging for the first time, you must read the information in “Installation and connection – General battery information”.

Fine dust filter (HX FSF-2)

To continue achieving the best possible cleaning results, replace the fine dust filter that is fitted as standard with a new one after approx. 3 years (see “Maintenance – Cleaning the pre-filter and fine dust filter”).

Electrical connection

All work should be carried out by a suitably qualified and competent person in strict accordance with national and local safety regulations. The voltage and rated load are given on the data plate located underneath the vacuum cleaner. Please ensure that these match the household mains supply. The charger is supplied with a cable and moulded plug ready for connection to a 230V/50Hz AC single phase supply.

Test Marks	Electrical safety RCM Mark
------------	-------------------------------

Electrically suppressed according to	CISPR 14.1
-----------------------------------------	------------

Miele

Miele Australia Pty. Ltd.

ACN 005 635 398
ABN 96 005 635 398

Miele Head Office Melbourne:

Level 4, 141 Camberwell Road
Hawthorn East, VIC 3123

Miele Experience Centre Doncaster:

1136/7 Doncaster Shopping Centre
619 Doncaster Rd, Doncaster, VIC 3108

Miele Experience Centre South Melbourne:

206-210 Coventry Street
South Melbourne, VIC 3205

Miele Experience Centre and Office Sydney:

3 Skyline Place
Frenchs Forest, NSW 2086

Miele Experience Centre and Office Brisbane:

Tenancy 4C, 63 Skyring Terrace
Newstead, QLD 4006

Miele Experience Centre Gold Coast:

131 Ferry Road
Southport, QLD 4215

Miele Experience Centre and Office Adelaide:

83-85 Sir Donald Bradman Drive
Hilton, SA 5033

Miele Experience Centre and Office Perth:

205-207 Stirling Highway
Claremont, WA 6010

1300 464 353 (1300 4 MIELE)

www.miele.com.au

Miele New Zealand Limited

IRD 98 463 631

Miele Experience Centre and Head Office Auckland:

8 College Hill
Freemans Bay, Auckland 1011

Miele Experience Centre Wellington:

183 Featherston Street
Wellington 6011

0800 464 353 (0800 4 MIELE)

www.miele.co.nz

Miele Global Headquarters Germany

Miele & Cie. KG

Carl-Miele-Straße 29
33332 Gütersloh
Federal Republic of Germany