

HGM3000DF

*Sunbeam*

**DIAMONDFORCE™  
REVERSAGRILL™  
BBQ GRILL**

User Guide



\*Matrix shown on product is for illustrative purposes only

# Contents

Sunbeam's Safety Precautions	1
Features of your Sunbeam DiamondForce™ ReversaGrill BBQ Grill	2
Usage Instructions	4
Care & Cleaning	5
Temperature Setting Guide	6
Cooking Guide	7
Recipes	10
Troubleshooting	18

## Important instructions – retain for future use.

تأكد من تفهم احتياطات السلامة المذكورة اعلاه

請務必理解上述的安全預防措施。

Assurez-vous que les précautions ci-dessus relatives à la sécurité sont bien comprises

Versichern Sie sich, dass die obenstehenden Sicherheitsmaßnahmen Verstanden werden

Βεβαιώνετε πως οι παραπάνω προφυλάξεις ασφαλείας γίνονται κατανοητές

Pastikan bahwa tindakan-tindakan keselamatan seperti di atas dimengerti anda

Accertatevi che le suddette norme di sicurezza siano comprese a dovere

上記の注意事項をよくお読みになり、安全を御確認ください

Уверете се дека погоре споменатите мерки на претпазливост се добро разбрани

Asegúrese de que las precauciones de seguridad precedentes sean bien comprendidas

کاری بکنید کہ احتیاطهای بالا حتماً درک بشوند

ต้องแน่ใจว่า ข้อควรระวังเรื่องความปลอดภัยข้างต้น เป็นที่เข้าใจกันดี

Yukarda belirtilen güvenlik önlemlerinin anlaşıldığından emin olunuz

Xin kiểm chắc rằng những biện pháp làm an toàn kể trên được hiểu rõ

# Sunbeam's Safety Precautions

SUNBEAM DIAMONDFORCE™ REVERSAGRILL BBQ GRILL.

- Use well away from walls and curtains.
- Avoid using on metal surfaces e.g. sink.
- Do not use in confined spaces.
- For indoor use, adequate ventilation or an exhaust fan is recommended.
- Always use the appliance under a sheltered roof when cooking outdoors.
- Do not immerse the control probe in water or any other liquid.
- Ensure that the cord is kept well away from the cooking plate during use.
- Ensure the drip tray is in position before grilling.
- Do not touch the grill plate when in use. Avoid touching hot surfaces.
- Take care when removing food from the grill.
- The temperature of accessible surfaces may be high when the appliance is operating.
- Do not leave plastic utensils in contact with appliance while cooking.
- Use only the supplied temperature control probe Type 948, Model TC055 with this grill.
- Remove the control probe before cleaning the grill.
- After cleaning the grill ensure that the control probe inlet area is completely dry before using the grill again.

**Sunbeam is very safety conscious when designing and manufacturing consumer products, but it is essential that the product user also exercise care when using an electrical appliance. Listed below are precautions which are essential for the safe use of an electrical appliance:**

- Read carefully and save all the instructions provided with an appliance.
- Always turn the power off at the power outlet before you insert or remove a plug. Remove by grasping the plug - do not pull on the cord.
- Turn the power off and remove the plug when the appliance is not in use and before cleaning.
- Do not use your appliance with an extension cord unless this cord has been checked and tested by a qualified technician or service person.
- Always use your appliance from a power outlet of the voltage (A.C. only) marked on the appliance.
- Children should be supervised to ensure that they do not play with the appliance.
- The temperature of accessible surfaces may be high when the appliance is operating.
- Never leave an appliance unattended while in use.
- Do not use an appliance for any purpose other than its intended use.
- Do not place an appliance on or near a hot gas flame, electric element or on a heated oven.
- Do not place on top of any other appliance.
- Do not let the power cord of an appliance hang over the edge of a table or bench top or touch any hot surface.
- Do not operate any electrical appliance with a damaged cord or after the appliance has been damaged in any manner. If damage is suspected, return the appliance to the nearest Sunbeam Appointed Service Centre for examination, repair or adjustment.
- For additional protection, Sunbeam recommend the use of a residual current device (RCD) with a tripping current not exceeding 30mA in the electrical circuit supplying power to your appliances.
- Do not immerse the appliance in water or any other liquid unless recommended.
- Appliances are not intended to be operated by means of an external timer or separate remote control system.
- This appliance is intended to be used in household and similar applications such as: staff kitchen areas in shops, offices and other working environments; farm houses; by clients in hotels, motels and other residential type environments; bed and breakfast type environments.
- This appliance is not intended for use by persons (including children) with reduced physical, sensory or mental capabilities, or lack of experience and knowledge, unless they have been given supervision or instruction concerning use of the appliance by a person responsible for their safety.

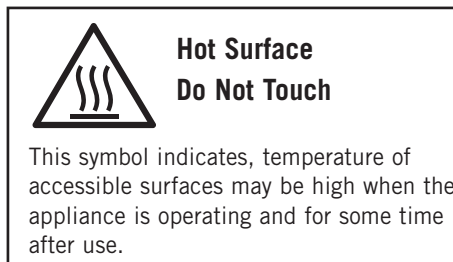

If you have any concerns regarding the performance and use of your appliance, please visit [www.sunbeam.com.au](http://www.sunbeam.com.au) or contact the Sunbeam Consumer Service Line.

Ensure the above safety precautions are understood.

# Features of your Sunbeam DiamondForce™ ReversaGrill BBQ

## Reversible grill plate

Cook on either side of the grill plate – ribbed grill plate for searing meats, seafood and vegetables, or flat hotplate for cooking eggs, crepes or pikelets.

## DiamondForce™ non-stick cooking surface

The DiamondForce™ coating advantage with advanced non-stick performance provides superior food release, requiring little to no oil when cooking food and easy wipe clean up.

## Large cooking area

Large cooking surface 45cm (18") x 27cm (11") enables you to cook an entire meal on the one grill surface.

## 2200 watts

High powered electric indoor grill with 2200 watts of grilling power, allows you to cook with high temperatures to sear meats and grill vegetables.

## Variable temperature control

The variable temperature probe is detachable from the grill and has a power indicator light. Turn the dial to adjust the thermostatically controlled temperatures for total cooking control.

**Note:** Although both sides are represented in this image, please note that the ReversaGrill comes with one grill plate that has two sides - one is ribbed, the other is flat.

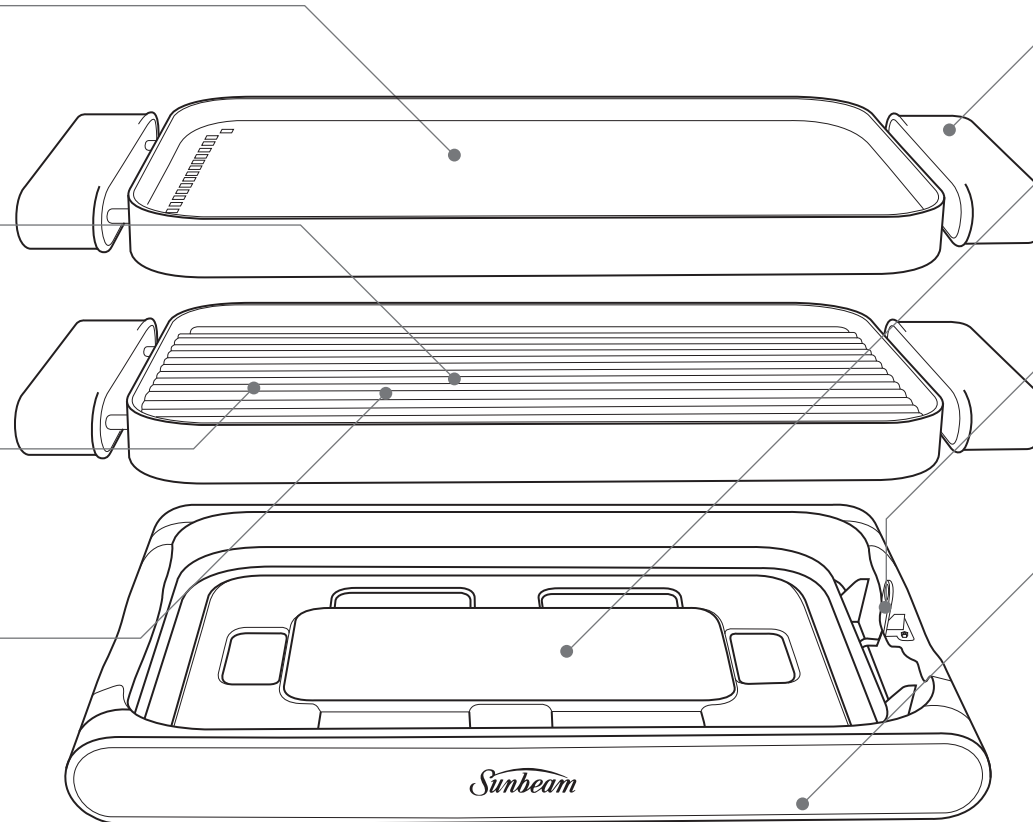

## Cool touch handles

Remains cool to the touch for safer cooking.

## Removable metal drip tray

Excess food crumbs, juices, grease or fat are channelled through the drip holes in the grill plate to collect in the metal drip tray.

## Safety interlock

The safety locking mechanism stops the grill from operating when the drip tray or grill have not been positioned correctly. This prevents heat damage to your table surface or the moulded base.

## Moulded base

The cool touch moulded base is finished with brushed stainless steel side panels and supports the grill plate and drip tray.

## Dishwasher safe

The grill plate and moulded base are fully immersible and dishwasher safe for easy cleaning.

## Cleaning spatula

Two sided spatula can be used to safely scrape food residue off the flat plate or the ribbed plate.

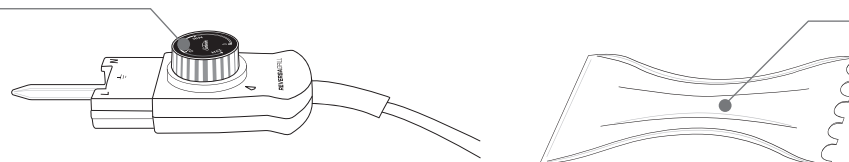

# Usage Instructions

## Before First Use

Before using your ReversaGrill for the first time, remove all packaging and promotional materials from the cooking plate, drip tray, base, control probe and cleaning spatula.

With the control probe detached, wash the cooking plate, drip tray and base with warm soapy water using a mild household detergent.

Rinse and dry thoroughly. Make sure the interior of the probe inlet is fully dry.

**Note:** Do not immerse the heat control probe in water or any other liquid.

Condition the cooking plates to protect the non-stick surface by applying a light coating of vegetable oil or use a non-stick cooking spray. Wipe off excess oil.

For easy cleaning line the drip tray with aluminium foil to collect the fats and juices. Place drip tray into base.

Ensure the drip tray and grill plate are correctly positioned over the base to deactivate the safety locking mechanism.

**Note:** When using the ReversaGrill for the first time you may notice a fine smoke haze being emitted from the unit. This is normal. It is due to the initial heating of internal components.

## Using your ReversaGrill

1. Place on a flat, level, heat-resistant surface.
2. Insert the control probe fully into the probe inlet of the grill plate.
3. Plug the cord into a 230-240 volt AC power outlet and turn the power ON.
4. Set the control probe dial to the desired heat setting or the recommended temperature setting for your required recipe.
5. Preheat until the thermostat light switches off, indicating the ReversaGrill is ready to use.

**Note:** The thermostat light on the control probe indicates the ReversaGrill is heating. This light will remain on until the set temperature has been reached and then will cycle on and off during cooking to ensure the selected temperature is maintained. The preheat time will depend on the heat setting selected.

**Note:** When grilling on high heat settings, the ReversaGrill will generate smoke. Selecting a lower heat setting will reduce smoke. For indoor use, adequate ventilation or an exhaust fan is recommended.

6. After you have completed grilling turn the power OFF and unplug from the power outlet.

**Note:** Ensure the cord is kept well away from the cooking plates when in use.

**Caution:** Do not touch the grill plate when in use. Avoid touching hot surfaces. Take care when removing food from the grill. Do not transport the grill when it is hot.

# Care & Cleaning

Use heat-resistant plastic or wooden utensils when cooking on the grill. Always use these utensils only to remove food from the grill.

Do not use sharp or metal objects as these will scratch the non-stick surface.

Do not cut food on top of the cooking plates.

Do not leave plastic utensils in contact with the cooking plate while in use.

## To clean after use

Always turn the power off and remove the plug from the power outlet and the control probe from the probe inlet before cleaning. Allow the ReversaGrill to cool before cleaning.

## DiamondForce™ non-stick grill plate

The element in the grill plate is cast in, so it is safe to fully immerse in water.

Wash the grill plate in warm soapy water using a mild household detergent and a soft washing sponge.

When cleaning DiamondForce™ non-stick coating, do not use abrasives or metal scourers as they will scratch the non-stick surface.

A bottle brush may be used to clean the drip holes in the grill plate.

Be sure to clean the handles after each use. The grill plate is also dishwasher safe. When the plate has cooled down, you may wipe using a paper towel to remove residue on the grill. With the control probe detached, wash with warm soapy water using a mild household detergent. Rinse thoroughly and dry the plate with a soft cloth, also make sure the interior of the probe inlet is fully dry before storage.

To remove stubborn food residues, use the plastic cleaning spatula provided, only when the grill plate has completely cooled.

## Moulded base

The base can be wiped over with a damp cloth or washed in warm soapy water using a mild household detergent and a soft washing sponge.

Do not use abrasives or metal scourers as they may scratch the exterior surface.

The moulded base is also dishwasher safe.

Dry the base thoroughly before storing.

## Drip tray

Lift the metal drip tray out from the base and pour any excess grease or liquid into a container and dispose of appropriately. Do not pour oil or fats down the sink.

Wash the metal drip tray in warm soapy water using a mild household detergent and a soft washing sponge.

Dry the drip tray thoroughly before storing.

Do not place the metal drip tray in the dishwasher.

## Control probe

If cleaning is necessary, wipe over with a damp cloth.

**Important:** Do not immerse the control probe in water or any other liquid. Do not place the control probe in the dishwasher.

Do not knock or drop the probe as this can damage the probe. If damage is suspected, return the control probe to your nearest Sunbeam Service Centre for inspection.

**Note:** Before inserting the control probe into the probe inlet, ensure the interior of the inlet is completely dry. To do this wipe interior of probe inlet with a dry cloth or shake out excess water vigorously.

## Storage

Allow the grill to cool completely and clean it after each use and dry thoroughly before storing it away.

# Temperature Setting Guide

The settings on the dial represent the following temperatures approximately. Pre-heat your grill on MAX setting then change to your desired setting.

DIAL SETTING	CELCIUS (approx)	USES	TEMPERATURE
MIN	50°C - 100°C	Keeping food warm	LOW
MIN/MED	85°C - 140°C		
MED	120°C - 180°C	Perfect for vegetables	MEDIUM
MED/MAX	160°C - 210°C		
MAX	195°C - 250°C	Perfect for thicker cuts of meat	HIGH

**Note:** The temperature settings are a guide only and may require adjustment to suit various foods and individual tastes. When the dial is set to a MIN setting, it is quite normal for food to stop and start bubbling, as the thermostat maintains the selected temperature.

# Cooking Guide

Meat/cut Variety	Preparation	Cooking Temperatures	Cooking Times	
			Medium	Well Done
<b>CHICKEN</b> Single breast fillet, skinless (160g)	Trim excess fat. Using a sharp knife cut each chicken breast in half horizontally. Brush or spray with oil. Season with salt and pepper.	Turn dial to MED/MAX	Chicken should be cooked to well done only.	2-3 minutes each side. Rest for 3-5 minutes before slicing.
Tenderloins (45 - 50g)	Trim excess fat. Brush or spray with oil. Season with salt and pepper.	Turn dial to MED/MAX		2 ½ - 3 minutes each side.
Thigh fillet (100 - 120g)	Trim excess fat. Brush or spray with oil. Season with salt and pepper.	Turn dial to MED/MAX		5-6 minutes each side. Rest for 3-5 minutes before slicing.
<b>SAUSAGE</b> Thin (8 x 80-85g each)	Do not pierce. Brush or spray with oil.	Turn dial to MAX	Sausages should be cooked to well done only.	12-15 minutes (8 sausages).
Thick (8 x 120-125g each)	Do not pierce. Brush or spray with oil.	Turn dial to MAX		20-25 minutes (8 sausages).
<b>LAMB</b> Loin chops (90-100g each 2 ½ cm thick)	Trim excess fat. Brush or spray with oil. Season with salt and pepper.	Turn dial to MAX		4 minutes each side.
Lamb leg, or rump steak (100-120g, 2 ½cm thick)	Trim excess fat. Brush or spray with oil. Season with salt and pepper.	Turn dial to MAX		4 minutes each side.
Cutlets, frenched (6 x 60g each)	Trim excess fat. Brush or spray with oil. Season with salt and pepper.	Turn dial to MAX	2 - 2 ½ minutes each side.	2 ½ - 3 minutes each side.
Lamb sirloin or backstrap (eye of loin) (200 - 220g)	Brush or spray with oil. Season with salt and pepper.	Turn dial to MAX	2 - 4 ½ minutes. Rest for 3 - 5 minutes before slicing.	3 - 3 ½ minutes each side. Rest for 3-5 minutes before slicing.

# Cooking Guide

# Cooking Guide

Meat/cut Variety	Preparation	Cooking Temperatures	Cooking Times	
			Medium	Well Done
<b>PORK</b> Pork loin chops (160-170g each)	Trim excess fat. Brush or spray with oil. Season with salt and pepper.	Turn dial to MAX		3 ½ - 4 minutes each side.
<b>BEEF</b> Beef Porterhouse steak (boneless) (175-190g, 2cm thick)	Trim excess fat. Brush or spray with oil. Season with salt and pepper.	Turn dial to MAX	Medium/Rare 2 minutes each side. Medium 2 ½ minutes each side.	Medium/Well 3 minutes each sided. Cover and rest for 3-5 minutes.
Beef Scotch fillet (200g, 2cm thick)	Trim excess fat. Brush or spray with oil. Season with salt and pepper.	Turn dial to MAX	Medium/Rare 2 ½ minutes each side. Medium 3 minutes each side.	Medium/Well 3 ½ minutes each side. Cover and rest for 3-5 minutes.
Hamburger patties (120g 12cm in diameter)	Brush or spray with oil.	Turn dial to MED		2 ½ - 3 minutes each side.
<b>FISH</b> Salmon (250g)	Brush or spray with oil. Season with salt and pepper.	Turn dial to MED	6 minutes each side.	
White fish (120g - 140g)	Brush or spray with oil. Season with salt and pepper.	Turn dial to MED	3 - 3 ½ minutes each side.	

1. Tender cuts of meat such as scotch fillet and sirloin are ideal for grilling. Tougher cuts of meat such as topside or blade steak will tenderise if marinated for a few hours or overnight.
2. Avoid overcooking meat as the texture will toughen.
3. Recommended cuts;  
Beef = Sirloin, Rump, Scotch, Fillet or T-Bone  
Lamb = Backstrap or Fillet, Chops and Cutlets  
Pork = Leg or Butterfly Steaks, Fillets and Chops.
4. You can also grill diced meat on skewers for kebabs.
5. The ReversaGrill can grill meats over 2.5cm (1 inch) thick with ease. If cooking meats with a bone it is recommended that it is no larger than 1.5cm thick to ensure even cooking.
6. The ribbed grill plate is ideal for cooking a variety of meats, including beef, lamb,

pork, poultry and fish. Take care when grilling fish, use a plastic spatula. The ribbed plate is also ideal for grilling vegetables.

7. The grill bars and drip holes allow the fats and juices to drain into the drip tray for healthy, fat free cooking.
8. The flat hotplate is ideal for cooking a variety of foods such as eggs, bacon, tomatoes, crepes and pikelets.
9. When cutting meats, chicken, vegetables or seafood for kebabs, cut evenly and uniform in size to ensure even cooking.

**Note:** Never cross-contaminate foods. Do not cut raw vegetables and raw meats with the same knife or on the same chopping board. Try to use separate chopping boards for meats, vegetables and seafood.

**Note:** Do not cut cooked meats on the same chopping board that you used to prepare the raw meat unless the board and knife have been thoroughly sanitised and cleaned in hot soapy water.

# Recipes

All recipes have been specifically created and tested by the Sunbeam Test Kitchen for the ReversaGrill™ BBQ. We hope you enjoy using your Sunbeam ReversaGrill™.

## Beef Burgers

**Serves: 4**

**Preparation: 15 minutes**

**Cooking: 6 minutes**

400g beef mince

1 small red onion, grated

½ cup fresh breadcrumbs

1 egg, lightly beaten

1 tablespoon Worcestershire sauce

2 tablespoons finely chopped fresh parsley

salt and freshly ground black pepper

cooking oil spray

4 hamburger buns, toasted

Tomato, beetroot and lettuce, to serve

1. Combine mince, onion, breadcrumbs, egg, Worcestershire sauce, parsley, salt and pepper in a bowl. Mix together. Shape into four 12cm patties. Place on a plate lined with baking paper. Cover and place in the fridge for 30 minutes.

2. Preheat flat plate on setting MED. Spray plates with cooking oil. Cook patties for 2 ½ minutes each side or until cooked through. Serve patties on toasted hamburger buns with sliced tomato, beetroot and lettuce.

## BLTs

**Serves: 4**

**Preparation: 10 minutes**

**Cooking: 6 minutes**

4 thick rashers bacon, rind and fat removed

2 large tomatoes, sliced

8 slices bread, toasted

mayonnaise

salt and freshly ground black pepper

8 lettuce leaves, torn

1. Preheat flat plate on setting MED. Cook bacon for 2-3 minutes each side or until golden.

2. Layer bacon and tomato evenly between toast that has been spread with mayonnaise. Season with salt and pepper. Top with lettuce. Sandwich together. Cut in half to serve.

# Recipes

## Steak Sandwich

**Serves: 4**

**Preparation: 10 minutes**

**Cooking: 10 minutes**

1 tablespoon olive oil

2 teaspoons balsamic vinegar

2 teaspoons brown sugar

2 medium red onions, sliced

4 (100g each) thin steaks, flattened

Turkish bread and barbecue sauce, to serve

1. Combine oil, vinegar and sugar in a bowl. Add onion and toss to coat.

2. Preheat flat plate or grill plate on setting MED/MAX. Cook onions, turning from time to time for 5-6 minutes or until golden. Remove onions; cover and keep warm.

3. Cook steaks for 1-2 minutes each side or until cooked as desired. Serve steaks on Turkish bread with onions and barbecue sauce.

## Sweet Chilli Chicken Burger with Lemon Mayonnaise

**Serves: 4**

**Preparation: 15 minutes (+ 2-4 hours marinating time)**

**Cooking: 6 minutes**

2 large single chicken breast fillets, trimmed

⅓ cup sweet chilli sauce

⅓ cup good-quality whole-egg mayonnaise

1 teaspoon finely grated lemon rind

1 tablespoon freshly squeezed lemon juice

4 hamburger buns, split, toasted to serve

1 baby cos lettuce, leaves separated, washed, dried, shredded

2 vine-ripened tomatoes, sliced

1 large dill gherkin, sliced

1. Use a sharp knife to cut each chicken breast horizontally in half to make four pieces of chicken. Place in a large glass bowl. Add sauce and turn to coat. Cover with plastic wrap and place in the fridge for 2-4 hours to marinate.

2. Preheat flat plate or grill plate on setting MED/MAX. Cook chicken for 2-3 minutes each side or until browned and cooked. Transfer to a plate.

3. Meanwhile, combine the mayonnaise, rind and juice in a small glass bowl.

4. Place half the toasted buns on serving plates. Spread with a little of the mayonnaise; top with lettuce, tomato, gherkin and chicken. Dollop with a little extra mayonnaise and then with remaining bread. Serve.

# Recipes

## Club Sandwich with Pancetta

**Serves: 4**

**Preparation: 10 minutes**

**Cooking: 12 minutes**

- 1/3 cup good-quality whole egg mayonnaise
- 1 tablespoon seeded mustard
- 1 tablespoon finely chopped fresh basil leaves
- 2 single chicken breast fillets, trimmed
- 1 tablespoon olive oil
- 8 slices mild pancetta
- 4 eggs
- 12 slices wholemeal bread, toasted
- 2 small tomatoes, sliced
- 8 thin slices Jarlsberg cheese
- 1. Combine the mayonnaise, mustard and basil in a small glass bowl. Cover with plastic wrap and set aside until required.
- 2. Use a sharp knife to cut each chicken breast in half horizontally to make 4 pieces. Place in a bowl. Drizzle with oil. Season with salt.
- 3. Preheat flat plate or grill plate on setting MED/MAX. Cook chicken for 2-3 minutes each side or until browned and cooked. Transfer to a plate. Cover with foil.
- 4. Cook pancetta for 1-2 minutes each side or until crispy. Transfer to a plate lined with paper towel.
- 5. Cook eggs for 1 minute each side or until cooked to your liking. Transfer to a plate.
- 6. Spread one-third of the toasted bread with mayonnaise. Top with tomato, cheese and egg. Top with another slice of bread and spread with remaining mayonnaise.
- 7. Top with chicken and pancetta and remaining bread. Secure with toothpicks. Cut each sandwich into triangles. Serve.

## Corn Fritters

**Makes: 12**

**Preparation: 15 minutes**

**Cooking: 12 minutes**

- 4 corn cobs
- 1/3 cup parsley leaves
- 1 cup self-raising flour
- 3 eggs
- 4 green onions, thinly sliced
- salt and freshly ground black pepper
- cream cheese, rocket and smoked salmon, to serve
- 1. Remove corn kernels from cobs. Place half the corn in a food processor. Add parsley, flour and eggs. Pulse until combined.
- 2. Transfer to a bowl. Add remaining corn and green onions. Season with salt and pepper.
- 3. Preheat flat plate on setting MED. Add heaped tablespoons mixture. Cook for 2-3 minutes each side or until golden.
- 4. Serve fritters topped with cream cheese, smoked salmon and rocket.

# Recipes

## Prawns with Chilli and Coriander

**Makes: 24**

**Preparation: 15 minutes**

**Cooking: 3 minutes**

- 2 tablespoons peanut oil
- 2 tablespoons finely chopped fresh coriander
- 2 tablespoons sweet chilli sauce
- 2 tablespoons lime juice
- 24 large green prawns, heads removed, peeled, leaving tails intact
- Lime wedges, to serve
- 1. Combine oil, coriander, sweet chilli sauce and lime juice in a bowl.
- 2. Add prawns and toss to coat in mixture. Cover and place in the fridge to marinate for 30 minutes.
- 3. Preheat flat plate or grill plate on setting MED/MAX. Cook prawns for 2-3 minutes or until golden. Serve with lime wedges.

## Balsamic and Rosemary Lamb

**Serves: 4**

**Preparation: 12 minutes**

**Cooking: 8 minutes**

- 1/4 cup olive oil
- 1 1/2 tablespoons balsamic vinegar
- 1 tablespoon chopped rosemary leaves
- 2 cloves garlic, crushed
- salt and freshly ground black pepper
- 2 (230g each) lamb loin eye (backstrap)
- Potatoes and green salad, to serve
- 1. Combine oil, vinegar, rosemary, garlic, salt and pepper in a shallow dish.
- 2. Add lamb and toss to coat in mixture. Cover and place in the fridge to marinate for 1-2 hours.
- 3. Preheat grill plate on the MAX setting. Cook lamb for about 3-4 minutes each side or until cooked as desired. Stand for 5 minutes before slicing. Serve lamb with potatoes and green salad.



# Recipes

## Beef Fajitas

Serves: 4

Preparation: 20 minutes

Cooking: 14 minutes

600g skirt steak

½ cup orange juice

½ cup pineapple juice

½ cup soy sauce

1 red capsicum, sliced

1 yellow capsicum, sliced

1 red onion, sliced

½ iceberg lettuce, shredded

1 cup grated cheese

½ cup sour cream

½ cup salsa

1 avocado, chopped

8-12 flour tortillas, warmed

1. Trim any fat from beef. Place beef in a deep dish and pour over the combined juices and soy sauce. Marinate in refrigerator for at least 2 hours.
2. Preheat flat plate on the MAX setting. Remove beef from marinade; reserve liquid. Cook beef on grill for about 4-5 minutes each side or until cooked as desired. Remove, cover with foil while the vegetables cook.
3. Cook for vegetables for 2-3 minutes. Pour over some of the reserved liquid over the vegetables and cook for a further 1 minute. Remove from heat.
4. Slice beef across the grain into thick slices.
5. To serve fajitas, place a little of each of the beef, vegetables and remaining ingredients in the flour tortilla and roll up.

## Pepper Steak with Mushrooms

Serves: 4

Preparation: 12 minutes

Cooking: 10 minutes

¼ cup olive oil

4 (160g-180g each) beef scotch fillets

2 teaspoons cracked pepper

350g portobello mushrooms, thickly sliced

2 teaspoons Worcestershire sauce

1 tablespoon finely chopped fresh parsley

potato mash, to serve

1. Brush steaks with 1 tablespoon olive oil and sprinkle with cracked pepper. Lightly press pepper onto steaks.
2. Preheat flat plate or grill plate on setting MED/MAX. Toss mushrooms in remaining oil. Cook for 3-4 minutes or until soft. Transfer mushrooms to a bowl, add Worcestershire sauce and parsley. Cover to keep warm.
3. Preheat flat or grill plate on the MAX setting. Cook steaks for 2-3 minutes each side or until cooked as desired. Serve steaks with mushrooms and potato mash.

# Recipes

## Oregano and Lemon Chicken

Serves: 4

Preparation: 10 minutes

Cooking: 8 minutes

2 tablespoons olive oil

½ cup lemon juice

1 tablespoon finely chopped fresh oregano

salt and freshly ground black pepper

12 chicken tenderloins, trimmed

tzatziki and salad leaves to serve

1. Combine oil, lemon juice, oregano, salt and pepper in a shallow dish. Add chicken and toss to coat in mixture. Cover and place in the fridge to marinate for 1-2 hours.
2. Preheat flat plate or grill plate on the MAX setting. Cook chicken for about 2-3 minutes each side or until cooked. Serve chicken with tzatziki.

## Pesto Chicken Skewers

Makes: 8

Preparation: 15 minutes (+ 15 minutes marinating time)

Cooking: 10 minutes

800g chicken breast fillets, trimmed, cut into 2cm pieces

½ cup bought basil pesto

Cooking oil spray

1. Thread chicken onto skewers. Place in a shallow dish. Brush with pesto and turn to evenly coat. Cover and place in the fridge for 15 minutes to marinate.
2. Preheat flat plate or grill plate on the MAX setting. Spray chicken with cooking oil. Season with freshly ground black pepper. Cook, turning occasionally, for about 10 minutes or until brown and cooked through. Serve.

# Recipes

## Souvlaki Lamb Cutlets

**Serves: 4**

**Preparation: 10 minutes (+marinating time)**

**Cooking: 5-7 minutes**

- 18 small lamb cutlets, trimmed
- 2 cloves garlic, crushed
- 1 tablespoon finely chopped fresh oregano
- 2 tablespoons lemon juice
- ¼ cup olive oil

1. Combine lamb, garlic, oregano, lemon juice and olive oil in a shallow dish. Place lamb and toss to coat in mixture. Cover and place in fridge to marinate for 1-2 hours.
2. Preheat flat plate or grill plate on the MAX setting.
3. Cook lamb for 2-3 minutes each side or until cooked as desired.

## Grilled Salmon with Lime Aioli

**Serves: 4**

**Preparation: 7 minutes**

**Cooking: 12 minutes**

- 2 tablespoons olive oil
- ¼ cup lime juice
- salt and freshly ground black pepper
- 4 (200g each) salmon fillets
- lime aioli, to serve

1. Combine oil, lime juice, salt and pepper in a shallow dish. Add salmon and toss to coat in mixture.
2. Preheat flat plate or grill plate on setting MED. Cook salmon for 5-6 minutes each side or until cooked as desired. Serve salmon with lime aioli.

# Recipes

## Buttermilk Pikelets

**Makes: 18**

**Preparation: 15 minutes**

**Cooking: 12-18 minutes**

- 1 egg
  - ¼ cup caster sugar
  - 1 cup self-raising flour, sifted
  - pinch salt
  - ½ teaspoon bi-carb soda
  - ⅔-¾ cup buttermilk
  - 30g butter, melted
1. Beat egg and sugar with an electric mixer until light and creamy.
  2. Add sifted flour, bi-carb soda, salt and buttermilk and beat until smooth.
  3. Preheat flat plate on setting MED. Spray with cooking oil spray. Add tablespoons of mixture and cook for 2-3 minutes each side or until golden.

## Ricotta Pancakes

**Makes: 6**

**Preparation: 15 minutes**

**Cooking: 18 minutes**

- 1 cup self-raising flour
  - 1 teaspoon baking powder
  - pinch salt
  - ¼ cup caster sugar
  - 125g fresh ricotta cheese
  - 1 egg, lightly beaten
  - 1 cup milk
  - 40g butter, melted
1. Sift flour, baking powder and salt into a bowl. Stir in sugar.
  2. Place ricotta in a separate bowl. Add egg and beat together. Gradually add milk and beat until combined.
  3. Add ricotta mixture and butter to dry ingredients. Whisk until smooth.
  4. Preheat flat plate on setting MIN/MED. Add ⅓ cup mixture. Cook for 2-3 minutes each side or until puffed and golden.
  5. Serve with raspberries, banana, honey or yoghurt.

# Troubleshooting

Problem	Potential Cause	Solution
<b>Overcooked / Undercooked Foods</b>	<ul style="list-style-type: none"> <li>Incorrect temperature</li> </ul>	<ul style="list-style-type: none"> <li>You may have to adjust the time and temperature to desired taste. Refer to "Temperature Setting Guide" section.</li> </ul>
<b>Burning Smell</b>	<ul style="list-style-type: none"> <li>The temperature on your control probe is too high. Adjust temperature accordingly.</li> </ul>	<ul style="list-style-type: none"> <li>Refer to "Temperature Setting Guide" section.</li> </ul>
<b>Heating elements do not stay ON</b>	<ul style="list-style-type: none"> <li>Heating elements will cycle ON and OFF to maintain proper heat</li> </ul>	<ul style="list-style-type: none"> <li>The thermostat light on the control probe indicates the temperature at which the dial is set. The light will remain on until the set temperature has been reached and then will cycle on and off throughout the cooking. This will ensure that the ReversaGrill maintains the correct temperature. On the initial heating of the ReversaGrill, it is recommended that the temperature be allowed to cycle (the light cycling on and off) several times. This will help the cooking surface to adjust to a more accurate cooking temperature.</li> </ul>



This Sunbeam product is covered by a 12 month replacement or repair warranty, which is in addition to your rights under the Australian Consumer Law (if your product was purchased in Australia) or New Zealand Consumer Guarantees Act (if your product was purchased in New Zealand).

Upon receipt of your claim, Sunbeam will seek to resolve your difficulties or, if the product is defective, advise you on how to obtain a replacement or refund.

To assist us in managing warranty claims, we recommend you register your product as soon as practicable after purchase by creating a MySunbeam account on our website and uploading a copy of your original receipt.

In order to make a claim under our warranty, you must have the original proof of purchase documentation for the product and present it when requested (if not already uploaded to our website).

Should your product develop any defect within 12 months of purchase because of faulty materials or workmanship, we will replace or repair it, at our discretion, free of charge. A product presented for repair may be replaced by a refurbished product of the same type rather than being repaired. Refurbished parts may be used to repair the product.

Our replacement or repair warranty only applies where a defect arises as a result of faulty material or workmanship during the warranty period. Your warranty does not cover misuse or negligent handling (including damage caused by failing to use the product in accordance with this instruction booklet), accidental damage, or normal wear and tear.

Your warranty does not:

- cover freight or any other costs incurred in making a claim, consumable items, accessories that by their nature and limited lifespan require periodic renewal (such as filters and seals) or any consequential loss or damage; or
- cover damage caused by:
  - power surges, power dips, voltage supply problems, or use of the product on incorrect voltage;

- servicing or modification of the product other than by Sunbeam or an authorised Sunbeam service centre;
- use of the product with other accessories, attachments, product supplies, parts or devices that do not conform to Sunbeam specifications; or
- exposure of the product to abnormally corrosive conditions; or

- extend beyond 3 months if the product is used in commercial, industrial, educational or rental applications.

**The benefits given to you by our warranty are in addition to other rights and remedies under law in relation to the product.**

**In Australia our goods come with guarantees that cannot be excluded under the Australian Consumer Law. You are entitled to a replacement or refund for a major failure and for compensation for any other foreseeable loss or damage. You are also entitled to have the goods repaired or replaced if the goods fail to be of acceptable quality and the failure does not amount to a major failure.**

**Our goods also come with guarantees that cannot be excluded under the New Zealand Consumer Guarantees Act.**

If your warranty claim is not accepted, we will inform you and if requested to do so by you, repair the product provided you pay the usual charges for such repair. You will also be responsible for all freight and other costs.

Should your product require repair or service after the warranty period, contact your nearest Sunbeam service centre. For a complete list of Sunbeam's service centres, visit our website or call our customer service line for advice on 1300 881 861 in Australia, or 0800 786 232 in New Zealand.

Should you experience any difficulties with your product during the warranty period, please contact our customer service line for advice on 1300 881 861 in Australia, or 0800 786 232 in New Zealand.

## Australia

www.sunbeam.com.au  
1300 881 861  
Suite 1, Level 1,  
13 Lord Street,  
Botany NSW 2019  
Australia

## New Zealand

www.sunbeam.co.nz  
0800 786 232  
Level 6, Building 5,  
Central Park, 660-670  
Great South Road,  
Greenlane, Auckland  
New Zealand

## Need help with your appliance?

Contact our customer service team or visit our website for information and tips on getting the most from your appliance.

Australia | visit [www.sunbeam.com.au](http://www.sunbeam.com.au)  
phone 1300 881 861  
mail Suite 1, Level 1,  
13 Lord Street,  
Botany NSW 2019  
Australia

New Zealand | visit [www.sunbeam.co.nz](http://www.sunbeam.co.nz)  
phone 0800 786 232  
mail Level 6, Building 5, Central  
Park, 660–670 Great South  
Road, Greenlane, Auckland.

Newell Australia Pty Ltd | ABN 68 075 071 233

Sunbeam is a registered trade mark.

Made in China to Sunbeam's specification.

Due to minor changes in design or otherwise,

the product you buy may differ slightly from the one shown here.

Approved by the appropriate electrical regulatory authorities.

©Copyright Sunbeam 2021.

02/21

HGM3000DF\_21EM1 (ANZ)

GCDS-SUN-JC