

# Sunbeam

## ON-THE-GO FRESH Portable Air Purifier

### User Guide

SAP0800WH, SAP0800BK, SAPF0800



## Contents

|                               |   |
|-------------------------------|---|
| Sunbeam's Safety Precautions  | 1 |
| What's included in your box   | 2 |
| Control Panel & Features      | 3 |
| Features of your Air Purifier | 4 |
| Getting Started               | 4 |
| Operating Instructions        | 5 |
| Care and maintenance          | 5 |
| Replacing filter              | 6 |
| Troubleshooting               | 7 |
| Warranty Information          | 8 |

## Important Instructions - retain for future use

تأكد من تفهم احتياطات السلامة المذكورة اعلاه

請務必理解上述的安全預防措施。

Assurez-vous que les précautions ci-dessus relatives à la sécurité sont bien comprises

Versichern Sie sich, dass die obenstehenden Sicherheitsmaßnahmen Verstanden werden

Βεβαιώνετε πως οι παραπάνω προφυλάξεις ασφαλείας γίνονται κατανοητές

Pastikan bahwa tindakan-tindakan keselamatan seperti di atas dimengerti anda

Accertatevi che le suddette norme di sicurezza siano comprese a dovere

上記の注意事項をよくお読みになり、安全を御確認ください

Уверете се дека погоре споменатите мерки на претпазливост се добро разбрани

Asegúrese de que las precauciones de seguridad precedentes sean bien comprendidas

کاری بکنید کہ احتیاط‌های بالا حتماً درک بشوند

ต้องแน่ใจว่า ข้อควรระวังเรื่องความปลอดภัยข้างต้น เป็นที่เข้าใจกันดี

Yukarda belirtilen güvenlik önlemlerinin anlaşıldığından emin olunuz

Xin kiểm chắc rằng những biện pháp làm an toàn kể trên được hiểu rõ

## Sunbeam's Safety Precautions

When using electrical appliances, basic safety precautions should always be followed to reduce the risk of fire, electric shock, and injury to persons. These precautions include:

- Read all instructions before using the appliance.
- Read the maintenance instructions before opening the appliance.
- To avoid fire or shock hazard, plug the appliance directly into appropriate electrical outlet.
- If the filter is covered by a bag when shipped, remove plastic bag before use and keep away from children.
- Keep the cord out of heavy traffic areas. To avoid fire hazard, never put the cord under rugs, near heat registers, radiators, stoves, or heaters.
- To protect against electrical hazards, do not immerse the appliance or use near water or other liquids.
- This appliance is not intended for use by children or by persons with reduced physical, sensory, or mental capabilities, or lack of experience and knowledge, unless they have been given supervision or instruction concerning use of the appliance by a person responsible for their safety. Close supervision is necessary when any appliance is used near children. Children should be supervised to ensure that they do not play with the appliance. Keep the appliance and its cord out of reach of children.
- Always turn the appliance off before unplugging it.
- Always unplug the air purifier before moving or cleaning the unit, opening the filter chamber cover, changing the filters and whenever the unit is not in use. To disconnect the unit, be sure to pull the plug and not the cord.
- Never drop or insert any objects into the openings of the unit.
- Do not operate any appliance with a damaged cord or plug. If the air purifier fails to operate or the unit has been dropped or damaged in any manner, return appliance to manufacturer for examination and/or repair. Appliances that are obviously damaged must not be operated.
- Use appliance only for intended household use as described in this manual. Any other use not recommended by the manufacturer may cause fire, electric shock, or injury to persons.
- Do not use outdoors.
- Never place on a soft surface such as a bed or sofa as this could cause the unit to tip over and block the air inlet or outlet grills.
- Keep unit away from heated surfaces and open flames.
- Do not place anything on top of unit.
- Prior to cleaning or other maintenance, the appliance must be disconnected from the supply mains.
- Never use detergents, gasoline, glass cleaner, furniture polish, paint thinner or other household solvents to clean any part of the appliance.
- This appliance should only be used in a room with temperatures between 10° C and 40° C.
- WARNING: To reduce the risk of fire or electric shock, do not use this appliance with any solid-state speed control device.
- Do not place the appliance on a walkway or where someone may trip over it. Misplacement of the appliance may cause a trip and fall.
- CAUTION: To prevent risk of electric shock, remove cord plug from outlet before opening appliance. To prevent risk of fire, inspect and clean equipment regularly as noted in this manual.
- This appliance contains a UV-C emitter.
- Unintended use of the appliance or damage to the housing may result in the escape of dangerous UV-C radiation.
- ⚠ UV-C radiation may, even in little doses, cause harm to the eyes and skin. Do not operate the UV-C emitter outside the appliance.
- WARNING: The filter cover is provided to prevent exposure to excessive ultraviolet light. Do not defeat its purpose. Do not attempt to service without turning unit off.
- CAUTION: This equipment should be inspected frequently and collected dirt removed from it regularly to prevent excessive accumulation.

If you have any concerns regarding the performance and use of your appliance, please visit the Sunbeam website or contact the Sunbeam Consumer Service Line. Ensure the above safety precautions are understood.

## What's included in your box

- 1 Sunbeam On-The-Go Fresh Portable Air Purifier
- 1 USB Charging Cable
- 1 Sunbeam True HEPA Filter pre installed

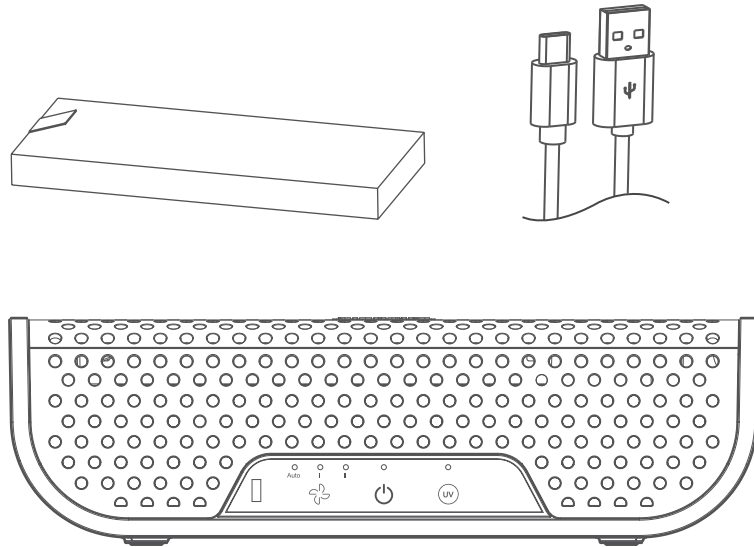

## Control panel and features



### On/Off button

Press and hold the On/off button for 1 second to turn the unit on, press and hold On/off button for 1 second to turn the unit off.



### Fan speed settings

Adjusts the speed between I (Low), II (High), Auto.



### UV Light

Turn the UV light on and off depending on your preference.

### AIR QUALITY INDICATOR & FILTER REPLACEMENT INDICATOR

| Colour of light | Air Quality |
|-----------------|-------------|
| Blue            | Good        |
| Orange          | Fair        |
| Red             | Poor        |

The light illuminates in red and starts flashing when it's time to replace your filter.

## Features of your air purifier

A battery operated fan with integral batteries or a separate/detachable battery pack shall be recharged only with the specified charger for the battery. A charger that may be suitable for one type of battery may create a risk of fire when used with another battery.

Use battery operated fan only with specifically designated battery pack. Use of any other batteries may create a risk of fire. When battery pack is not in use, keep it away from other metal objects such as paper clips, coins, keys, nails, screws, or other small metal objects that can make a connection from one terminal to another. Shorting the battery terminals together may cause sparks, burns, or a fire.

Risk of fire - Use battery operated fan only with installed battery. Battery is not removable or replaceable. Do not attempt to access.

## Getting started

1. Locate the filter door on the top of the unit. Remove cover by using rib and lift off.
2. Remove the plastic bag from the filter and re-insert the filter. Make sure the ribbon tab is exposed and the filter is pushed completely to ensure the unit operates properly.
3. Realign the cover and gently press it back into the unit.
4. Your unit is equipped with one True HEPA filter that last 6 months.

## PRODUCT DISPOSAL

This product contains an integral lithium battery which is not removable or replaceable. Do not incinerate this product, even if it is severely damaged. The batteries can explode in a fire. Do not dispose of product in normal household waste. We encourage you to help protect our environment and recycle this product through a local electronics recycling program. Please observe local regulations for proper disposal.

## Operating instructions

1. Place the unit on a dry, stable and firm surface. Make sure not to block the back air vent and air intake grille.
2. Press and hold the On/off button for 1 second to turn unit on, Press and hold the On/off button again to turn unit off.
3. Select desired fan speed setting I (Low), II (High), Auto Mode by pressing the Fan Speed button (  ) to cycle through the speeds until it reaches desired speed setting.
4. To turn the UV ON, press the UV button once until the White LED light next to the button is illuminated. Press the UV button again to turn the UV OFF.

## Care and maintenance

- Before cleaning the air purifier, turn the unit off.
  - Clean the exterior surface with a clean, damp cloth.
  - The back air vent can be cleaned of dust with a small, soft brush.
  - If you would like to clean the inside of the filter compartment, ONLY use a dry, soft cloth to wipe it down.
- WARNING:** Do not allow moisture to come into contact with the main housing of the air purifier. NEVER use detergents, gasoline, glass cleaner, furniture polish, paint thinner, or other household solvents to clean any part of the appliance.

## Replacing filter

It is recommended to replace the True HEPA filter every 6 months.

1. Remove cover by using rib and lift off.
2. Insert the new True HEPA filter. Make sure ribbon tab is exposed and the filter is pushed in completely to ensure the unit operates properly.
3. Realign the cover and gently press it back into the unit.
4. Turn the power ON.
5. To reset filter reminder, press and hold the Fan Speed Button for 3 seconds, the red flashing indicator will then turn off.

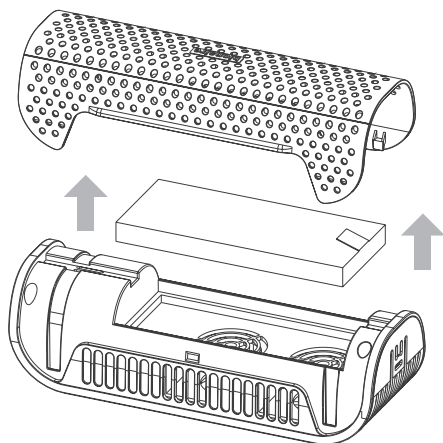

The filter indicator on the control panel will turn on in red and flash when it's time to replace your filters. For the best performance, replace the True HEPA Filter every 6 months.

Visit [www.sunbeam.com.au](http://www.sunbeam.com.au) to see which retailers sell our genuine Sunbeam SAPF0800 True HEPA filter replacements.

## Troubleshooting

For troubleshooting and FAQs visit [www.sunbeam.com.au](http://www.sunbeam.com.au).

| Problem                              | Solution  |
|--------------------------------------|---|
| Why is my unit not working?          | Make sure unit is turned ON.  |
|                                      | Make sure filter is properly installed and the filter door is correctly closed.         |
|                                      | Use USB cord to input 5 VDC 1.0A for battery charging.                                  |
| Why is there a decrease in air flow? | Make sure nothing is blocking air intake grille and filtered air outlet.                |
|                                      | Check condition of the filter and replace if necessary.                                 |
|                                      | Check filter to remove any plastic wrapping/packaging.                                  |
| Why is the unit making a loud noise? | Use USB cord to input 5VDC 1.0A for battery charging.                                   |
|                                      | Make sure parts are firmly positioned in place.   |
|                                      | Open the filter door and verify that any plastic packaging was removed from the filter. |



This product is covered by a 12 month replacement or repair warranty, which is in addition to your rights under the Australian Consumer Law (if your product was purchased in Australia) or New Zealand Consumer Guarantees Act (if your product was purchased in New Zealand).

Upon receipt of your claim, Sunbeam will seek to resolve your difficulties or, if the product is defective, advise you on how to obtain a replacement or refund.

To assist us in managing warranty claims, we recommend you register your product as soon as practicable after purchase, on our Sunbeam website and uploading a copy of your original receipt. View the Support section of the Sunbeam website.

In order to make a claim under our warranty, you must have the original proof of purchase documentation for the product and present it when requested (if not already uploaded to our website).

Should your product develop any defect within 12 months of purchase because of faulty materials or workmanship, we will replace or repair it, at our discretion, free of charge. A product presented for repair may be replaced by a refurbished product of the same type rather than being repaired. Refurbished parts may be used to repair the product.

Our replacement or repair warranty only applies where a defect arises as a result of faulty material or workmanship during the warranty period. Your warranty does not cover misuse or negligent handling

(including damage caused by failing to use the product in accordance with this instruction booklet), accidental damage, or normal wear and tear.

Your warranty does not:

- cover freight or any other costs incurred in making a claim, consumable items, accessories that by their nature and limited lifespan require periodic renewal (such as filters and seals) or any consequential loss or damage; or
- cover damage caused by:
  - power surges, power dips, voltage supply problems, or use of the product on incorrect voltage;

- servicing or modification of the product other than by Sunbeam or an authorised service centre;
- use of the product with other accessories, attachments, product supplies, parts or devices that do not conform to Sunbeam specifications; or
- exposure of the product to abnormally corrosive conditions; or

- extend beyond 3 months if the product is used in commercial, industrial, educational or rental applications.

**The benefits given to you by our warranty are in addition to other rights and remedies under law in relation to the product.**

**In Australia our goods come with guarantees that cannot be excluded under the Australian Consumer Law. You are entitled to a replacement or refund for a major failure and for compensation for any other foreseeable loss or damage. You are also entitled to have the goods repaired or replaced if the goods fail to be of acceptable quality and the failure does not amount to a major failure.**

**Our goods also come with guarantees that cannot be excluded under the New Zealand Consumer Guarantees Act.**

**If your warranty claim is not accepted, we will inform you and if requested to do so by you, repair the product provided you pay the usual charges for such repair. You will also be responsible for all freight and other costs.**

**Should your product require repair or service after the warranty period, contact your nearest service centre. For a complete list of service centres, visit our website or call our customer service line for advice on 1300 881 861 in Australia, or 0800 786 232 in New Zealand.**

**Should you experience any difficulties with your product during the warranty period, please contact our customer service line for advice on 1300 881 861 in Australia, or 0800 786 232 in New Zealand.**

---

**Australia**

www.sunbeam.com.au  
1300 881 861

**New Zealand**

www.sunbeam.co.nz  
0800 786 232

---

## **Need help with your appliance?**

Contact our customer service team or visit our website for information and tips on getting the most from your appliance.

Australia | visit [www.sunbeam.com.au](http://www.sunbeam.com.au)  
phone 1300 881 861

New Zealand | visit [www.sunbeam.co.nz](http://www.sunbeam.co.nz)  
phone 0800 786 232

Newell Australia Pty Ltd. ABN 68 075 071 233

Sunbeam is a registered trade mark.

Made in China to Sunbeam's specification.

Due to minor changes in design or otherwise,  
the product you buy may differ slightly from the one shown here.

Approved by the appropriate electrical regulatory authorities.

©Copyright Sunbeam 2022.