

**90cm dual fuel freestanding oven with 5 burner gas cooktop, multi-function 8 oven, AirFry, 125L gross capacity, and 19 mj/h wok burner with Hob2Hood.**

RRP AUS \$3,599.00



## Product Details

### FEATURES

AirFry	Fast Heat Up	Twin Fan System	Telescopic runners
Large 125L gross oven capacity	High powered, intense 19 MJ/h wok burner	Hob2Hood	Dual Valve Control
Digital Programmable timer	Cooler touch door For added safety and confidence in the kitchen, our cooler touch door is beautifully designed with a large window, so you can keep a close eye on your cooking.	Cast iron trivets	Triple glazed oven door glass
Handy storage compartment Extra storage always comes in handy, so with a clever storage compartment you can easily stow away any extra pots and pans.	Dark Stainless Steel Finish	Clip-on plinth included	LP Conversion Kit An LP conversion kit is supplied with all models for conversion by a qualified installer.

### BENEFITS

**AirFry for that perfect, crunch**  
When a food craving hits, make healthier and delicious food right in your oven with minimal oil. Deliver all the flavour and none of the guilt. AirFry allows you to make healthier, tasty meals for the entire family right in your oven.

**Fast heat up time**  
Every moment counts, so while your oven heats up super-fast you can save time and get on with cooking the dishes you and your family love.

#### Twin fan system for even cooking

Cook each dish to perfection with the Twin Fan System. Fans rotate in opposite directions, distributing heat evenly throughout the oven, so you enjoy great results every time.

#### Designed for ease and safety

Telescopic runners are another piece of thoughtful design that makes it easy to draw racks out and safely check on your dishes during cooking.

---

#### A hotter wok helps bring out the flavour

Use high heat to lock in the flavour of your dishes. With durable brass caps and 19 MJ/h you can bring your wok to high heat with even flame distribution. Spice up your cooking and spice up your life.

#### Clear the air with Hob2Hood

With Hob2Hood technology, compatible rangehoods work seamlessly with your Freestanding cooker to clear your kitchen of cooking smells and steam. As you start cooking, the rangehood will automatically turn on then intuitively adjust the fan speed and airflow to match your cooking. How's that for hands-free convenience?

---

#### Boil to simmer in an instant

For precision control cooking all your favourite recipes, our smart Dual Valve flame control lets you go from boil to simmer in an instant.

#### Built in Australia

Westinghouse, has been the heart of the home for generations and the kitchen appliance brand we have always known and trusted to build reliable products. This oven is built in a local factory in Adelaide.

---

## Specifications

### PRODUCT PROFILE

---

Domestic warranty details (yrs)	2
---------------------------------	---

---

Oven fuel	electric
-----------	----------

---

Materials/Colour	Dark stainless steel
------------------	----------------------

---

Controls of Oven	control knob,3 button touch control LED
------------------	---

---

Cooling fan	Yes
-------------	-----

---

Plinth colour (kickboard)	Dark stainless steel
---------------------------	----------------------

---

Anti tilt plate	Yes
-----------------	-----

---

Front/rear controls	front
---------------------	-------

---

### FLUSH FIT CUT OUT

---

Flush fit cut out height (mm)	900
-------------------------------	-----

---

Flush fit cut out width (mm)	900
------------------------------	-----

---

Flush fit cut out depth (mm)	600
------------------------------	-----

---

### DIMENSIONS

#### PRODUCT DIMENSION

---

Total height (mm)	910
-------------------	-----

---

Total width (mm)	895
------------------	-----

---

Total depth (mm)	600
------------------	-----

---

### MAIN OVEN

---

Gross capacity litres	125
-----------------------	-----

---

Useable capacity litres	116
-------------------------	-----

---

Oven function	multifunction
---------------	---------------

---

Number of functions	8
---------------------	---

---

## MAIN OVEN

Oven liner	pyrolux high temperature enamel
Timer functions	duration,end,minute minder,oven start,Countdown,24 hour clock
Lights	2
Light wattage	25
Light position	top
Light activation by door	Yes
Layers of glass in door	3
Telescopic runners	one
Shelf support	Easy glide side racks
Number of shelves	2
Number of shelf positions	5
Closed door grilling	Yes

## ELECTRICAL CONNECTION

Connected load KW	4.3
-------------------	-----

## SHIPPING

Shipping Volume (m3)	0.675
----------------------	-------

## ELECTRICAL CONNECTION

---

Maximum current rating (amps)	17.9
-------------------------------	------

---

Type of connection	hardwired
--------------------	-----------

---

## SHIPPING

---

Shipping Weight (Kg)	82
----------------------	----

---

Pack Dimensions Height (mm)	900
-----------------------------	-----

---

Pack Dimension Width (mm)	1000
---------------------------	------

---

Pack Dimension Depth (mm)	750
---------------------------	-----

---

## STUFFING QUANTITIES

---

20ft	32
------	----

---

40ft	64
------	----

---

40ft HC	90
---------	----

---

## COOKTOP (IF APPLICABLE)

### PRODUCT PROFILE

---

Cook top type	gas
---------------	-----

---

Materials/Colour	stainless steel
------------------	-----------------

---

Knob finish	Metalised dark finish
-------------	-----------------------

---

## ELEMENTS/BURNERS

---

Cooking zones	5
---------------	---

---

## LEFT REAR ZONE

---

Left rear zone	semi-rapid
----------------	------------

---

## FEATURES

---

Trivets	cast iron
---------	-----------

---

## CONTROLS

---

Position of controls	front
----------------------	-------

---

Ignition type	electronic
---------------	------------

---

## GAS SPECIFICATIONS

---

Maximum gas rating (NG)	54
-------------------------	----

---

Position of connection	rear right
------------------------	------------

---

# Dimensions

## 90cm freestanding cooker

WFE9515SD,  
WFE9516DD,  
WFEP9717DD

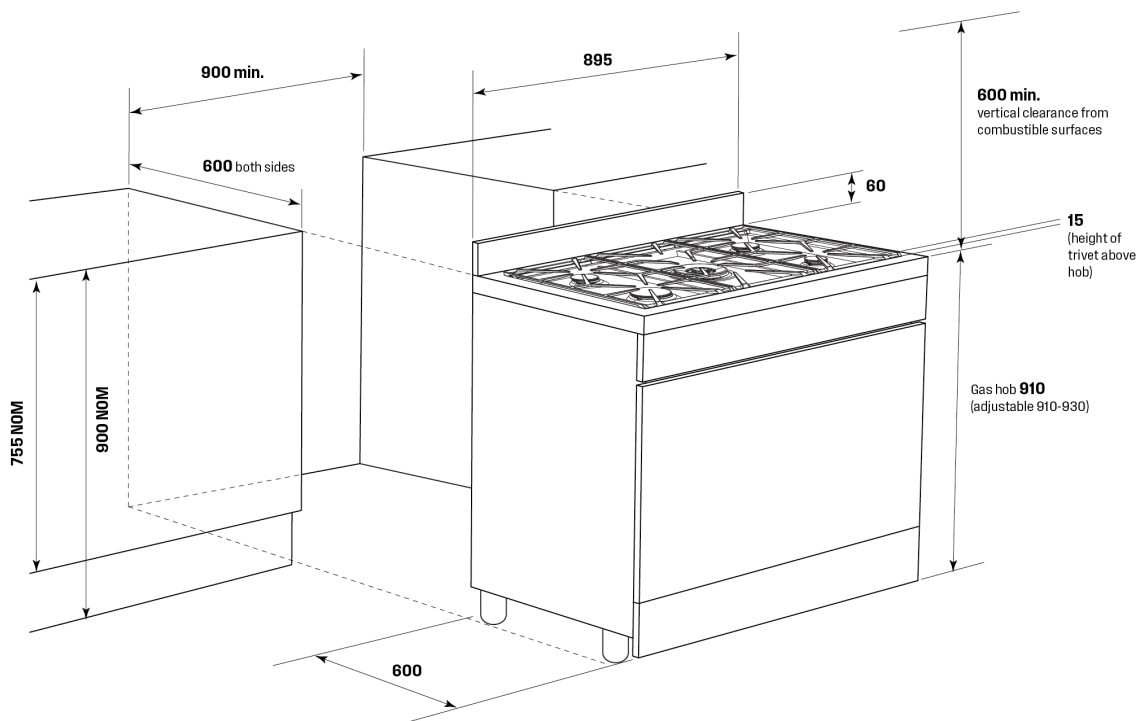

**IMPORTANT**

These dimensions are a guide only. All measurements are in millimetres (mm).  
For complete installation instructions, refer to the manual provided with product.



# Terms and Conditions

## IMPORTANT

This is a guide of product dimensions only. For complete installation instructions, refer to the manual provided with product.

## PRODUCT INFORMATION

The descriptors and illustrations in this publication apply to the specific products and models described as at the date of issue. Under our policy of continuous product development, product specifications may change without notice. Prospective purchasers should therefore check with their retailer to ensure this publication correctly describes the products that are being offered for sale. All information supplied is to be used for general reference purposes only and is on the understanding that Electrolux Home Products Pty Ltd (Australia) and Electrolux (NZ) Ltd (New Zealand) will not be liable for any loss, liability or damage of whatever kind arising as a result of reliance on such information. Colours of products illustrated are as close as printing limitations allow. Electrolux will at all times comply with its obligations pursuant to law including Trade Practices (Australian Consumer Law) Act and Regulations.

## WARRANTY

This warranty only applies to Appliances purchased and used in Australia or New Zealand and used in normal domestic applications and is in addition to (and does not exclude, restrict, or modify in any way) any non-excludable statutory warranties in Australia or New Zealand. All warranties are subject to the conditions set out in the warranty card accompanying the product when purchased.

### ELECTROLUX HOME PRODUCTS AUSTRALIA

telephone: 1300 363 640

fax: 1800 350 067

email: [customercare@electrolux.com.au](mailto:customercare@electrolux.com.au)

web: [www.electrolux.com.au](http://www.electrolux.com.au)

### ELECTROLUX HOME PRODUCTS NEW ZEALAND

telephone: 09 573 2230

fax: 09 573 2221

email: [customercare@electrolux.co.nz](mailto:customercare@electrolux.co.nz)

web: [www.electrolux.co.nz](http://www.electrolux.co.nz)