

ASSEMBLY



WASH FILTERS

Wash filters with cold water at least every month. Ensure the filters are completely dry before refitting.

Powerful suction
Up to 40 minutes (25 minutes with motorised head)

Max mode
7 minutes

REGISTER YOUR DYSON 2 YEAR GUARANTEE TODAY

DYSON CUSTOMER CARE

THANK YOU FOR CHOOSING TO BUY A DYSON APPLIANCE

Your Dyson appliance will be covered for parts and labour for 2 years (excluding filters) from the date of purchase, as detailed in the terms of the Dyson guarantee in this Dyson Operating Manual.

If you have a query about your Dyson appliance, call the Dyson Customer Care Helpline quoting your serial number and details of where and when you bought the appliance. Alternatively, contact us via the website.

Visit our website to register your Dyson full parts and labour guarantee online, and for online help, support videos, general tips and useful information about Dyson.

AU: www.dyson.com.au/register

NZ: www.dyson.co.nz/register

DYSON CUSTOMER CARE

Australia

Website: www.dyson.com.au

Email: aucustomer@dyson.com

Dyson Customer Care: 1800 239 766

(Mon-Fri 8:00am to 6:00pm EST,

Sat-Sun 8:30am to 4:00pm EST).

Address: Dyson Appliances (Aust) Pty Ltd.,

PO Box 2835, Taren Point, NSW 2229 Australia.

New Zealand

Website: www.dyson.co.nz

Email: dyson@averyrobinson.co.nz

Dyson Customer Care: 0800 397 667

(Mon-Fri 8:30am to 5:00pm).

Address: Avery Robinson Ltd., Unit F, 151D Marua Road, Ellerslie, Auckland, 1051 New Zealand.

Your serial number can be found on your rating plate which is on the base of the appliance.

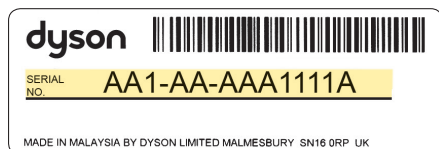
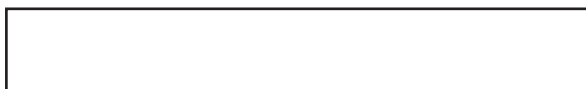

This illustration is for example purposes only.

3 EASY WAYS TO REGISTER YOUR DYSON 2 YEAR GUARANTEE

**REGISTER
ONLINE**
Visit our website to register your Dyson full parts and labour guarantee online.

AU: www.dyson.com.au/register
NZ: www.dyson.co.nz/register

**REGISTER
BY PHONE**
Call our dedicated Helpline.

AU 1800 239 766
NZ 0800 397 667

**REGISTER
BY MAIL**
Complete and return the form to Dyson in the envelope supplied.

IMPORTANT SAFETY INSTRUCTIONS

BEFORE USING THIS APPLIANCE READ ALL INSTRUCTIONS AND CAUTIONARY MARKINGS IN THIS MANUAL AND ON THE APPLIANCE

When using an electrical appliance, basic precautions should always be followed, including the following:

WARNING

These warnings apply to the appliance, and also where applicable, to all tools, accessories, chargers or mains adaptors.

TO REDUCE THE RISK OF FIRE, ELECTRIC SHOCK, OR INJURY:

1. This appliance is not intended for use by persons (including children) with reduced physical, sensory or reasoning capabilities, or lack of experience and knowledge, unless they have been given supervision or instruction by a responsible person concerning use of the appliance to ensure that they can use it safely.
2. Do not allow to be used as a toy. Close attention is necessary when used by or near children. Children should be supervised to ensure that they do not play with the appliance.
3. Use only as described in this Dyson Operating Manual. Do not carry out any maintenance other than that shown in this manual, or advised by the Dyson Customer Care Helpline.
4. Suitable for dry locations ONLY. Do not use outdoors or on wet surfaces.
5. Do not handle any part of the plug or appliance with wet hands.
6. Do not use with a damaged cable or plug. If the supply cable is damaged it must be replaced by Dyson, its service agent or similarly qualified person in order to avoid a hazard.
7. If the appliance is not working as it should, has received a sharp blow, has been dropped, damaged, left outdoors, or dropped into water, do not use and contact the Dyson Customer Care Helpline.
8. Contact the Dyson Customer Care Helpline when service or repair is required. Do not disassemble the appliance as incorrect reassembly may result in an electric shock or fire.
9. Do not stretch the cable or place the cable under strain. Keep the cable away from heated surfaces. Do not close a door on the cable, or pull the cable around sharp edges or corners. Arrange the cable away from traffic areas and where it will not be stepped on or tripped over. Do not run the appliance over the cable.
10. Do not unplug by pulling on the cable. To unplug, grasp the plug, not the cable. The use of an extension cable is not recommended.
11. Do not use to pick up water.
12. Do not use to pick up flammable or combustible liquids, such as petrol, or use in areas where they or their vapours may be present.
13. Do not pick up anything that is burning or smoking, such as cigarettes, matches, or hot ashes.
14. Keep hair, loose clothing, fingers, and all parts of the body away from openings and moving parts, such as the brush bar. Do not point the hose, wand or tools at your eyes or ears or put them in your mouth.
15. Do not put any object into openings. Do not use with any opening blocked; keep free of dust, lint, hair, and anything that may reduce airflow.
16. Use only Dyson recommended accessories and replacement parts.
17. Do not use without the clear bin and filter in place.
18. Unplug when not in use for extended periods and before maintenance or servicing.
19. Use extra care when cleaning on stairs.
20. Do not install, charge or use this appliance outdoors, in a bathroom or within 3 metres (10 feet) of a pool. Do not use on wet surfaces and do not expose to moisture, rain or snow.
21. Use only Dyson chargers for charging this Dyson appliance. Use only Dyson batteries: other types of batteries may burst, causing injury to persons and damage.
22. FIRE WARNING – Do not place this product on or near a cooker or any other hot surface and do not incinerate this appliance even if it is severely damaged. The battery might catch fire or explode.
23. Always turn 'OFF' the appliance before connecting or disconnecting the motorised brush bar.
24. FIRE WARNING – Do not apply any fragrance or scented product to the filter(s) of this appliance. The chemicals in such products are known to be flammable and can cause the appliance to catch fire.

READ AND SAVE THESE INSTRUCTIONS

THIS DYSON APPLIANCE IS INTENDED FOR HOUSEHOLD USE ONLY



Do not use near naked flames.



Do not store near heat sources.



Do not pick up water or liquids.



Do not pick up burning objects.



Do not put hands near the brush bar when the appliance is in use.



Do not place on or near the cooker.

Power mode and run-time

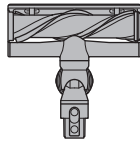
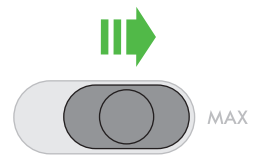
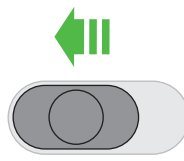
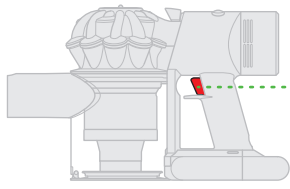

25 minutes



30 minutes

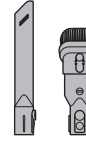

40 minutes

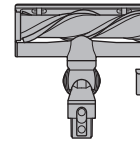

7 minutes

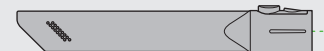
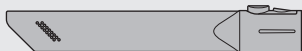
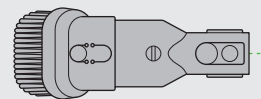
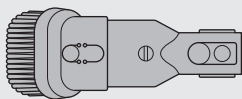
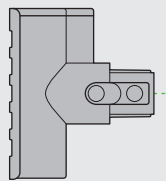
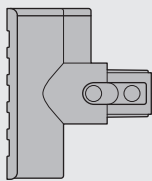
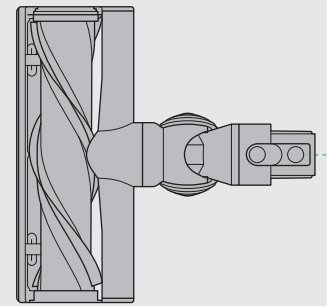
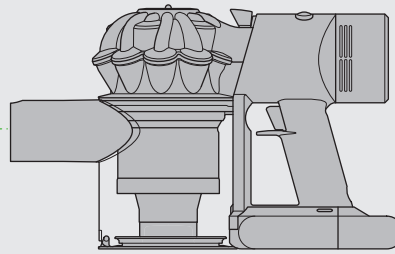
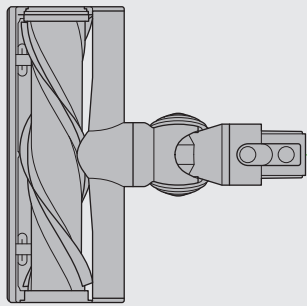

Recharging on the dock

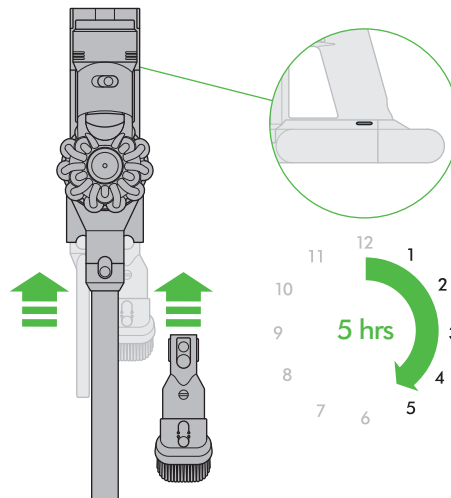
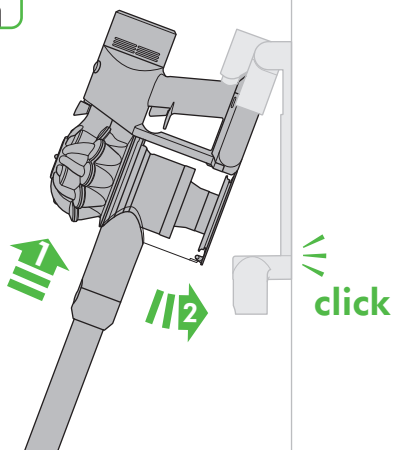

Light during charging

- Charging, low charge.
- Charging, medium charge.
- Charging, nearly full.
- Charged, on standby.
- Charger fault – call the Dyson Helpline.
- Battery fault – call the Dyson Helpline.

Emptying the clear bin

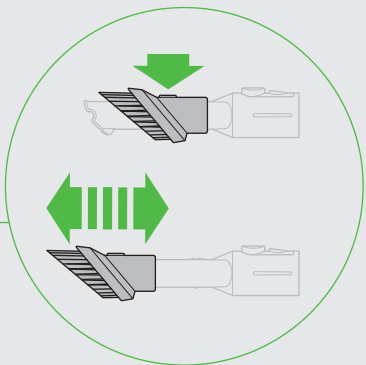
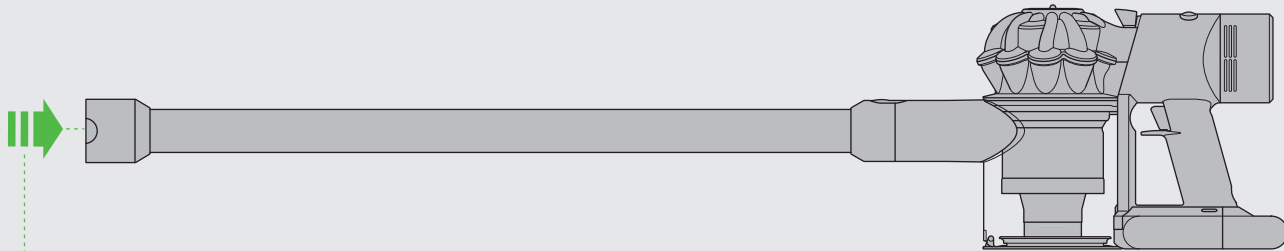
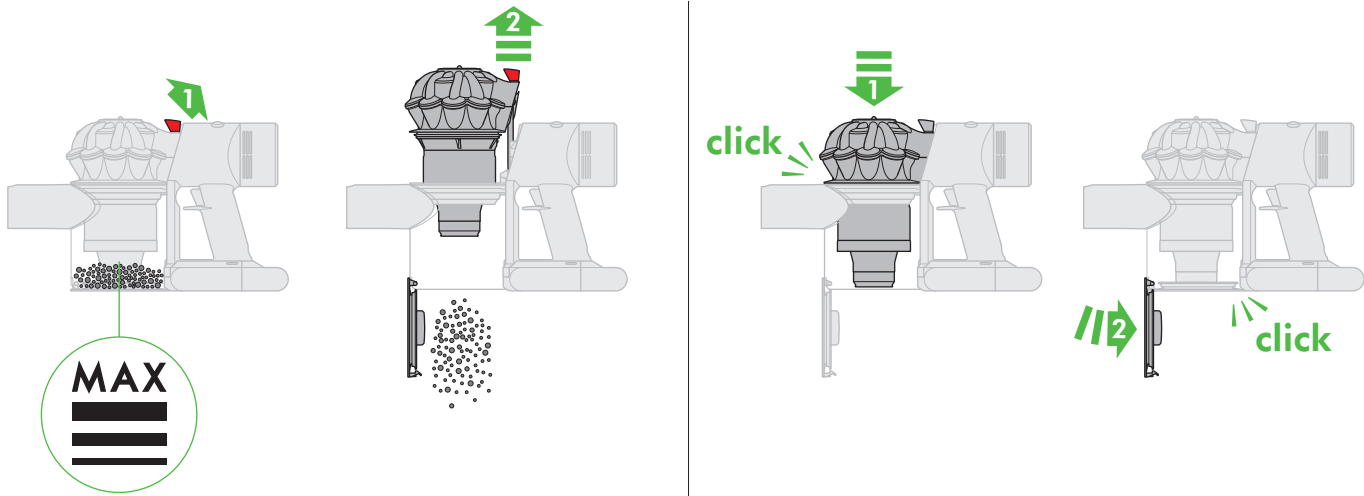



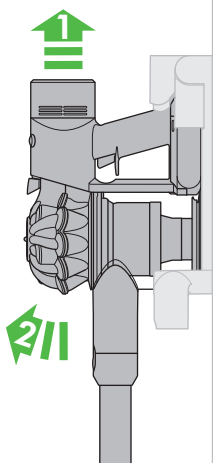

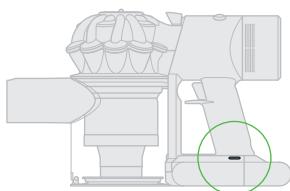

Removing from the dock



Light during use



-  High level of charge.
-  Medium level of charge.
-  Low level of charge.
-  Empty, needs recharging.
-  Battery fault – call the Dyson Helpline.
-  Main body fault – call the Dyson Helpline.

Looking for blockages

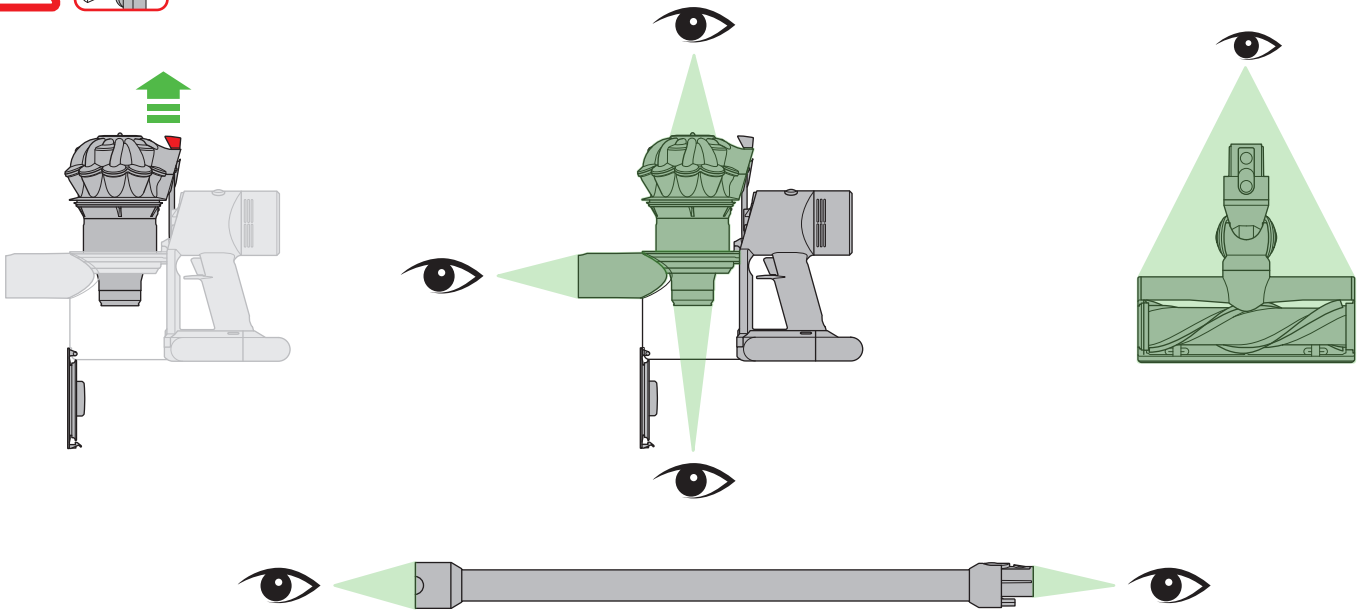

Stubborn blockages – Disassembly.

Reassembly

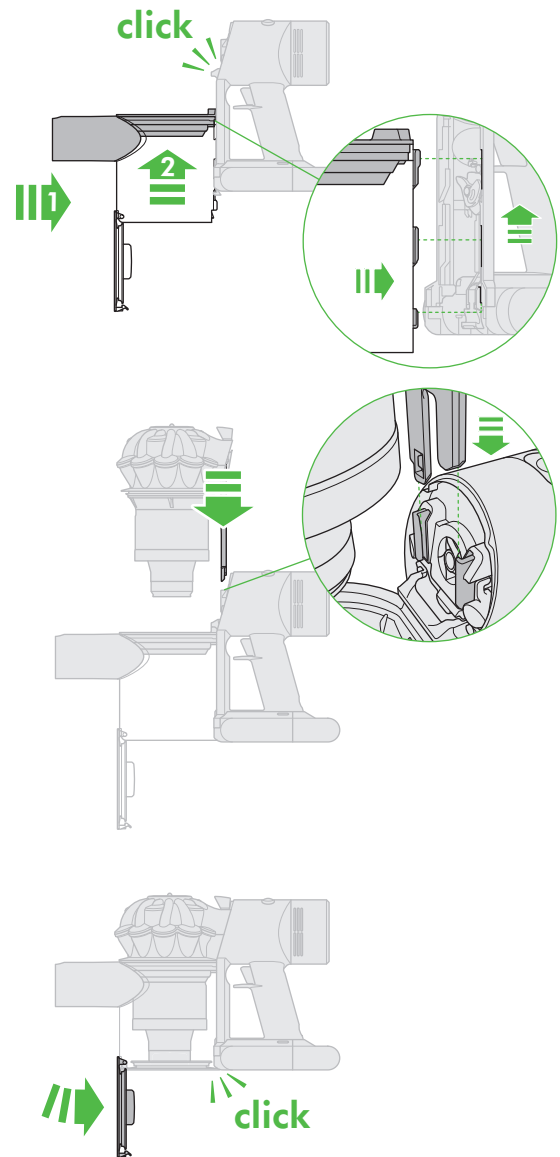
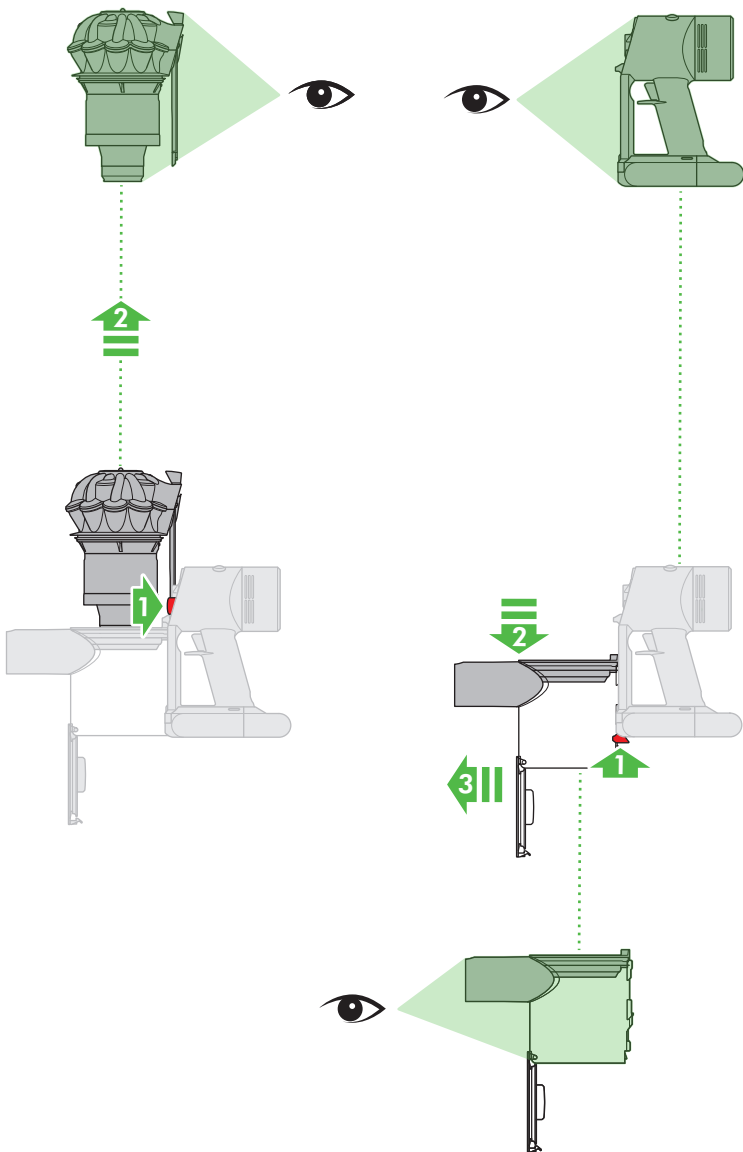

IMPORTANT!

WASH FILTERS

Wash filters with cold water at least every month. Ensure the filters are completely dry before refitting.

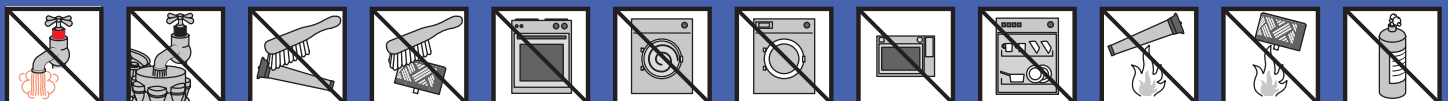
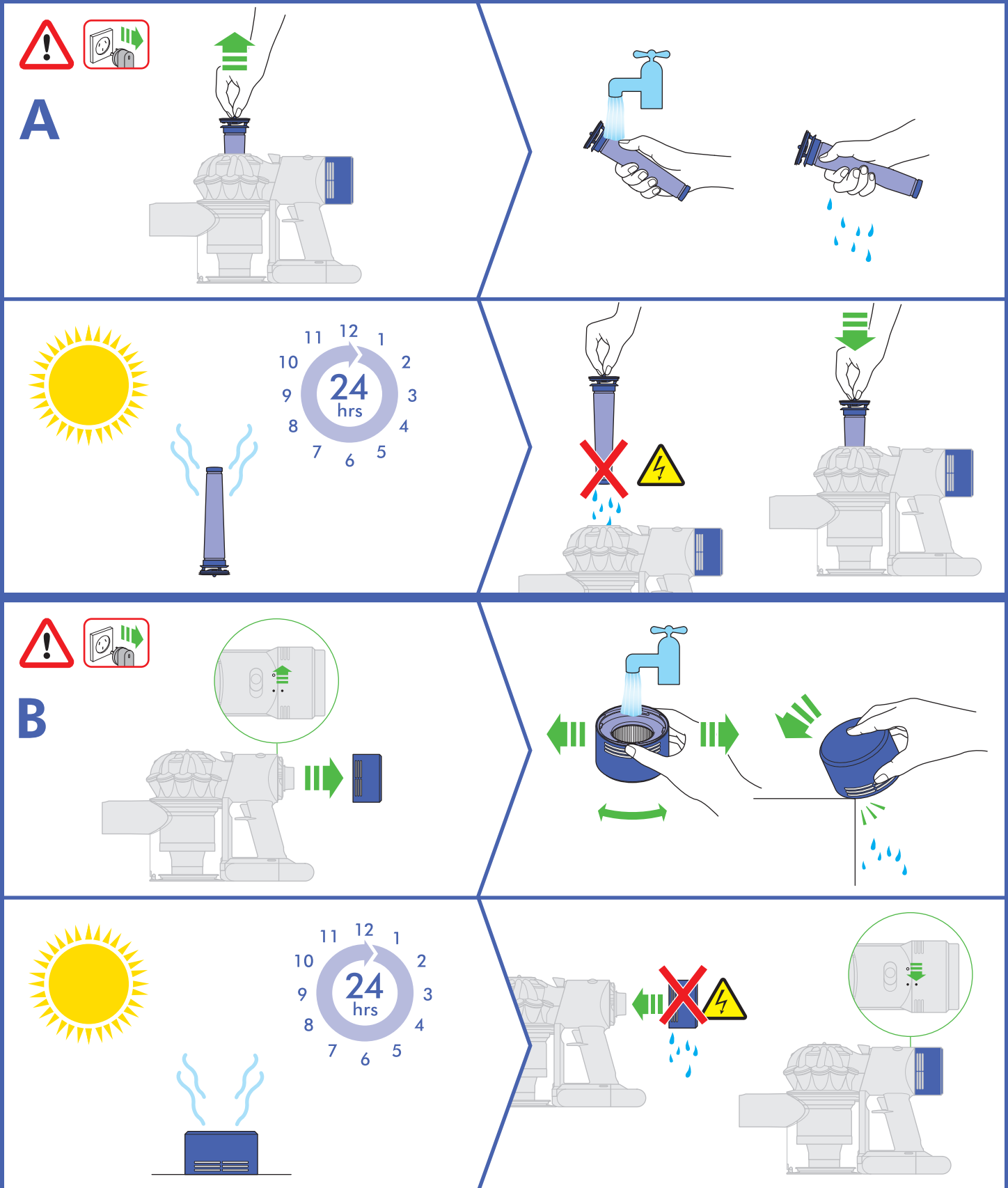

USING YOUR DYSON APPLIANCE

PLEASE READ THE 'IMPORTANT SAFETY INSTRUCTIONS' IN THIS DYSON OPERATING MANUAL BEFORE PROCEEDING.

OPERATION

- Do not use outdoors or on wet surfaces or to vacuum water or other liquids – electric shock could occur.
- Ensure the appliance remains upright in use and in storage. Dirt and debris may be released if it is turned upside down.
- Do not operate while checking for blockages.
- For domestic indoor and car use only. Do not use it whilst the car is in motion or while driving.
- To operate the Max mode, locate the switch on the top of the appliance. Slide the switch to the Max mode position.
- To switch off Max mode, slide the switch back to the Powerful Suction mode position.
- This product has carbon fibre brushes. Take care if coming into contact with them, as they may cause minor skin irritation. Wash your hands after handling the brushes.

DOCKING STATION INSTALLATION

Use appropriate mounting hardware for your wall type and ensure that the docking station is mounted securely. Ensure no pipe work (gas, water, air) or electrical cables, wires or ductwork are located directly behind the mounting area. The docking station must be mounted in accordance with regulations and applicable codes/standards (state and local laws may apply).

Dyson recommends the use of protective clothing, eyewear and materials as necessary.

CARPETS OR HARD FLOORS

- Before vacuuming your flooring, rugs and carpets, check the manufacturer's recommended cleaning instructions.
- The brush bar on the appliance can damage certain carpet types and floors. Some carpets will fuzz if a rotating brush bar is used when vacuuming. If this happens, we recommend vacuuming without the motorised floor tool and consulting with your flooring manufacturer.
- Before vacuuming highly polished floors, such as wood or lino, first check that the underside of the floor tool and its brushes are free from foreign objects that could cause marking.

LOOKING AFTER YOUR DYSON APPLIANCE

- Do not carry out any maintenance or repair work other than that shown in this Dyson Operating Manual, or advised by the Dyson Customer Care Helpline.
- Only use parts recommended by Dyson. If you do not this could invalidate your Dyson guarantee.
- Store the appliance indoors. Do not use or store it below 3°C (37.4°F). Ensure the appliance is at room temperature before operating.
- Clean the appliance only with a dry cloth. Do not use any lubricants, cleaning agents, polishes or air fresheners on any part of the appliance.
- Check the brush bar regularly and clear away any debris (such as hair). Debris left on the brush bar may cause damage to flooring when vacuuming.

VACUUMING

- Do not use without the clear bin and filters in place.
- Fine dirt such as flour should only be vacuumed in very small amounts.
- Do not use the appliance to pick up sharp hard objects, small toys, pins, paper clips, etc. They may damage the appliance.
- When vacuuming, certain carpets may generate small static charges in the clear bin or wand. These are harmless and are not associated with the mains electricity supply. To minimise any effect from this, do not put your hand or insert any object into the clear bin unless you have first emptied it. Clean the clear bin with a damp cloth only. (See 'Cleaning the clear bin'.)
- Use extra care when cleaning on stairs.
- Do not rest the appliance on chairs, tables, etc.
- Do not press down on the nozzle with excessive force when using the appliance as this may cause damage.
- Do not leave the cleaner head in one place on delicate floors.
- On waxed floors the movement of the cleaner head may create an uneven lustre. If this happens, wipe with a damp cloth, polish the area with wax, and wait for it to dry.

EMPTYING THE CLEAR BIN

- Empty as soon as the dirt reaches the level of the MAX mark – do not overfill.
- Ensure the appliance is disconnected from the charger before emptying the clear bin. Be careful not to pull the 'ON' trigger.
- To make emptying the clear bin easier, it is advisable to remove the wand and floor tool.
- To minimise dust/allergen contact when emptying, encase the clear bin tightly in a plastic bag and empty.
- To release the dirt, hold the appliance by the handle, pull the red lever back and lift upwards to release the cyclone. Continue until the bin base automatically opens and releases the dirt.
- Remove the clear bin carefully from the bag.
- Seal the bag tightly, dispose as normal.
- To close, push the cyclone downwards until it is in the normal position and manually close the base of the bin – the base will click when it is securely in place.

CLEANING THE CLEAR BIN

- Ensure the appliance is disconnected from the charger before removing the clear bin. Be careful not to pull the 'ON' trigger.
- Remove the wand and floor tool.
- To remove the cyclone, hold the appliance by the handle, pull the red lever towards you and lift upwards until the bin opens, then push in the red button located behind the cyclone and lift the cyclone out.
- To detach the clear bin from the appliance, pull back on the red catch located at the base, slide the clear bin down and carefully remove forwards from the main body.
- Clean the clear bin with a damp cloth only.
- Do not use detergents, polishes or air fresheners to clean the clear bin.
- Do not put the clear bin in a dishwasher.
- Ensure the clear bin is completely dry before replacing.
- To replace the clear bin, align the tabs on the clear bin with the grooves on the main body and slide upwards into place until the catch clicks.
- Slide the cyclone into the grooves of the main body and push downwards until it is in its normal position and manually close the base of the bin – the base will click when it is securely in place.

WASHING THE FILTERS

- Your appliance has two washable filters; wash the filters at least once a month according to the following instructions to maintain performance. More frequent washing may be required where the user: vacuums fine dust, operates mainly in 'Powerful suction' mode, or uses the machine intensively.

WASHING FILTER A

- Ensure the appliance is disconnected from the charger before removing the filter. Be careful not to pull the 'ON' trigger.
- Check and wash the filter regularly according to instructions to maintain performance.
- The filter may require more frequent washing if vacuuming fine dust or if used mainly in 'Powerful suction' mode.
- To remove the filter, lift it out of the top of the appliance.
- Wash the filter with cold water only.
- Run water over the outside of the filter until the water runs clear.
- Squeeze and twist with both hands to make sure the excess water is removed.
- Lay the filter on its side to dry. Leave to dry completely for a minimum of 24 hours.
- Do not put the filter in a dishwasher, washing machine, tumble dryer, oven, microwave or near a naked flame.
- To refit, place the dry filter back into the top of the appliance. Make sure it is fitted properly.

WASHING FILTER B

- To remove the filter, twist anti clockwise to the open position and pull away from the appliance.
- Wash the inside of the filter under cold running water, rotating the filter to ensure all pleats are covered.
- Gently tap the filter against the side of the sink several times to remove any debris.
- Repeat this process 4-5 times until the filter is clean.
- Place the filter upright, with the top of the filter facing upwards, and leave to dry completely for a minimum of 24 hours.
- To refit, return the filter to the open position and twist clockwise until it clicks into place.

LOOKING FOR BLOCKAGES

The motor will pulse when there is a blockage. Please follow the instructions below to locate the blockage:

- Ensure the appliance is disconnected from the charger before looking for blockages. Be careful not to pull the 'ON' trigger.
- Do not operate while checking for blockages. Failure to do so could result in personal injury.
- Beware of sharp objects when checking for blockages.
- To check for blockages in the main body of the appliance, remove the clear bin and cyclone as per the instructions in the cleaning the clear bin section and remove the blockage. Please consult the 'Stubborn blockages' section of the illustrations for further guidance.
- If you cannot clear an obstruction you may need to remove the brush bar. Use a coin to unlock the fastener marked with a padlock. Remove the obstruction. Replace the brush bar and secure it by tightening the fastener. Ensure it is fixed firmly before operating the appliance.
- This product has carbon fibre brushes. Take care if coming into contact with them, as they may cause minor skin irritation. Wash your hands after handling the brushes.
- Refit all parts securely before using.
- Clearing blockages is not covered by your Dyson guarantee.

BLOCKAGES – AUTOMATIC CUT-OUT

- This appliance is fitted with an automatic cut-out.
- If any part becomes blocked the appliance may automatically cut out.
- This will happen after the motor pulses a number of times (i.e switches on and off in quick succession).
- Leave to cool down before looking for blockages.
- Ensure the appliance is disconnected from the charger before looking for blockages. Failure to do so could result in personal injury.
- Clear any blockage before restarting.
- Refit all parts securely before using.
- Clearing blockages is not covered by your Dyson guarantee.

CHARGING AND STORING

- This appliance will switch 'OFF' if the battery temperature is below 3°C (37.4°F). This is designed to protect the motor and battery. Do not charge the appliance and then move it to an area with a temperature below 3°C (37.4°F) for storage purposes.
- To help prolong battery life, avoid recharging immediately after a full discharge. Allow to cool for a few minutes.
- Avoid using the appliance with the battery flush to a surface. This will help it run cooler and prolong battery run time and life.

BATTERY SAFETY INSTRUCTIONS

- If the battery needs replacing please contact the Dyson Customer Care Helpline.
- Use only Dyson chargers for charging this Dyson appliance.
- The battery is a sealed unit and under normal circumstances poses no safety concerns. In the unlikely event that liquid leaks from the battery do not touch the liquid and observe the following precautions:
 - Skin contact – can cause irritation. Wash with soap and water.
 - Inhalation – can cause respiratory irritation. Expose to fresh air and seek medical advice.
 - Eye contact – can cause irritation. Immediately flush eyes thoroughly with water for at least 15 minutes. Seek medical attention.
 - Disposal – wear gloves to handle the battery and dispose of immediately, following local ordinances or regulations.



CAUTION

The battery used in this device may present a risk of fire or chemical burn if mistreated. Do not disassemble, short contacts, heat above 60°C (140°F), or incinerate. Keep away from children. Do not disassemble and do not dispose of in fire.

DISPOSAL INFORMATION

Dyson products are made from high grade recyclable materials. Please dispose of this product responsibly and recycle where possible.

When your Dyson appliance reaches the end of its life, we are responsible for its safe disposal. You can send your old Dyson appliance back to us (at our cost) and we will organise for it to be recycled.*

*Please note that not all parts are recyclable. Recycling of parts is subject to the capabilities of 3rd party suppliers. Available in Australia only.

Simply:

1. Box up your old Dyson appliance.
2. Take the package to your local post office and send to the address below:

Dyson We Recycle
Reply Paid 83215
Dyson Service Centre
8–10 Mangrove Lane
Taren Point, NSW 2229

- Keep the used batteries away from children as these can still harm children if swallowed.
- Your filter unit is non-washable and non-recyclable.
- The battery should be removed from the product before disposal.

ONLINE SUPPORT

- For online help, general tips, videos and useful information about Dyson.
 - www.dyson.com.au/SV10support

DYSON CUSTOMER CARE

THANK YOU FOR CHOOSING TO BUY A DYSON APPLIANCE

After registering your 2 year Dyson guarantee, your Dyson appliance will be covered for parts and labour (excluding filters) for 2 years from the date of purchase, subject to the terms of the guarantee. If you have any questions about your Dyson appliance, call the Dyson Helpline with your serial number and details of where/when you bought the appliance. Most questions can be solved over the phone by one of our trained Dyson Helpline staff.

- If your Dyson appliance needs a service, call the Dyson Customer Care Helpline so we can discuss the available options.

LIMITED 2 YEAR GUARANTEE

TERMS AND CONDITIONS OF THE DYSON 2 YEAR LIMITED GUARANTEE

WHAT IS COVERED

- The repair or replacement of your Dyson appliance (at Dyson's discretion) if it is found to be defective due to faulty materials, workmanship or function within 2 years of purchase or delivery (if any part is no longer available or out of manufacture Dyson will replace it with a functional replacement part).
- This Dyson guarantee will only be valid if the appliance is used in the country in which it was sold.

WHAT IS NOT COVERED

Under your Dyson guarantee, Dyson shall not be liable for costs of repair or replacement of a product incurred as a result of:

- Accidental damage, faults caused by negligent use or care, misuse, neglect, careless operation or handling of the Dyson appliance which is not in accordance with this Dyson Operating Manual.
- Use of the Dyson appliance for anything other than normal domestic purposes in the country of purchase.
- Use of parts not assembled or installed in accordance with the instructions of Dyson.
- Use of parts and accessories other than those produced or recommended by Dyson.
- Repairs or alterations carried out by parties other than Dyson or its authorised agents.
- Damage from external sources such as transit, weather, electrical outages or power surges.
- Failures caused by circumstances outside Dyson's control.
- Blockages – please refer to the illustrations and the section 'Looking for Blockages' in this Dyson Operating Manual for details of how to look for and clear blockages.
- Normal wear and tear (e.g. fuse, brush bar etc.).
- Use of this appliance on rubble, ash, plaster.
- Reduction in battery discharge time due to battery age or use (cordless machines only).
- If your Dyson guarantee does not apply, you may have statutory rights and remedies available to you as a consumer.
- If your Dyson guarantee does not apply, you may have statutory rights and remedies available to you as a consumer. If you are in any doubt as to what is covered by your Dyson guarantee, please call the Dyson Customer Care Helpline.

AUSTRALIAN CONSUMER LAW

The details of the Dyson guarantee are set out below. In addition to your rights under the Dyson guarantee, we also provide the following statement as required by the Australian Consumer Law: In Australia, your Dyson appliance comes with statutory guarantees that cannot be excluded under the Australian Consumer Law. You are entitled to a replacement or refund for a major failure and for compensation for any other reasonably foreseeable loss or damage. You are also entitled to have your Dyson appliance repaired or replaced if it fails to be of acceptable quality and the failure does not amount to a major failure.

DYSON 2 YEAR GUARANTEE

TERMS AND CONDITIONS OF YOUR DYSON 2 YEAR GUARANTEE.

- The Dyson guarantee becomes effective from the date of purchase.
- All work will be carried out by Dyson Appliances (Aust) Pty Ltd., Avery Robinson Ltd. (NZ) or their authorised agents.
- Any parts replaced by Dyson or its service agents will become the property of Dyson Appliances (Aust) Pty Ltd. or Avery Robinson Ltd. (NZ).
- The repair or replacement of your Dyson appliance under the Dyson guarantee will not extend the period of the Dyson guarantee.
- The Dyson guarantee provides benefits which are additional to and do not affect your statutory rights as a consumer.
- You must provide proof of (both the original and any subsequent) delivery/purchase before any work can be carried out on your Dyson appliance. Without this proof, any work carried out pursuant to the Dyson guarantee and any associated delivery charges (both to and from us) will be at your cost, subject to your statutory rights and remedies as a consumer. Please keep your receipt or delivery note.

ABOUT YOUR PRIVACY

WHEN REGISTERING YOUR DYSON PRODUCT

- You will need to provide us with basic contact information to register your product and enable us to support your guarantee.
- When you register, you will have the opportunity to choose whether you would like to receive communications from us. If you opt-in to communications from Dyson, we will send you details of special offers and news of our latest innovations. We never sell your information to third parties and only use information that you share with us as defined by our privacy policies which are available on our website. www.dyson.com.au/support/privacypolicy

IMPORTANT!

WASH FILTERS

Wash filters with cold water at least every month. Ensure the filters are completely dry before refitting.

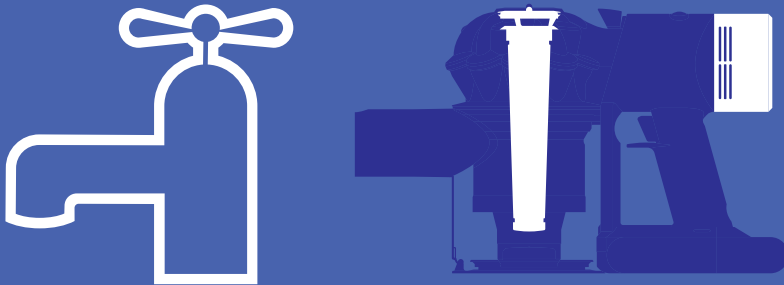

DYSON CUSTOMER CARE

Your Dyson appliance will be covered for parts and labour for 2 years (excluding filters) from the date of purchase, as detailed in the terms of the Dyson guarantee in this Dyson Operating Manual.

If you have a query about your Dyson appliance, call the Dyson Customer Care Helpline quoting your serial number and details of where and when you bought the appliance. Alternatively, contact us via the website.

Most queries can be solved over the phone by one of our Dyson Customer Care Helpline staff.

DYSON CUSTOMER CARE

Australia

Website: www.dyson.com.au

Email: aucustomer care@dyson.com

Dyson Customer Care: 1800 239 766

(Mon-Fri 8:00am to 6:00pm EST,

Sat-Sun 8:30am to 4:00pm EST).

Address: Dyson Appliances (Aust) Pty Ltd.,

PO Box 2835, Taren Point,

NSW 2229 Australia.

New Zealand

Website: www.dyson.co.nz

Email: dyson@averyrobinson.co.nz

Dyson Customer Care: 0800 397 667

(Mon-Fri 8:30am to 5:00pm).

Address: Avery Robinson Ltd., Unit F,

151D Marua Road, Ellerslie, Auckland,

1051 New Zealand.





GUARANTEE FORM

Date of purchase / /

Country of purchase Australia New Zealand

Serial number

Title Surname

First name

Address

Postcode

email

Telephone

Mobile

Store of purchase

Privacy Act

Dyson may use this information for future marketing and research purposes (including sending commercial electronic messages) and may disclose it to third parties for the purposes of providing the services you have requested or to our business partners or professional advisers. If you wish to access your personal information or see our full privacy policy, please contact us at aucustomercare@dyson.com

If you wish to receive marketing information by these methods from Dyson please tick this box.

3 EASY WAYS TO REGISTER YOUR DYSON 2 YEAR GUARANTEE

REGISTER ONLINE



Visit our website to register your Dyson full parts and labour guarantee online.

AU: www.dyson.com.au/register
NZ: www.dyson.co.nz/register

REGISTER BY PHONE



Call our dedicated Helpline.

AU 1800 239 766
NZ 0800 397 667

REGISTER BY MAIL



Complete and return the form to Dyson in the envelope supplied.

