

Installation guide

Built-in ovens

WARNING

The appliance must not be installed behind a decorative door in order to avoid overheating.

To avoid any potential hazard, you must follow our instructions when you install your appliance. Failure to install the appliance correctly could invalidate any warranty or liability claims and lead to prosecution.

This appliance must be installed by an authorised person according to all codes and regulations as stated in the local municipal building codes and other relevant statutory regulations.

- Wiring connections must be in accordance with AS/NZS 3000 Wiring Rules and any particular conditions of the local authority.
- Refer to data plate for rating information. The data plate is positioned behind the bottom of the oven door.
- For appliances with open cooking surfaces, a disconnect functional switch should be provided near the appliance in an accessible position. Refer to AS/NZS 3000 clause 4.7.1
- Wiring should be protected against mechanical failure. Refer to AS/NZS3000 clauses 3.3.2.6, 3.9, 3.10
- A means of disconnection with a contact separation of at least 3mm must be supplied in the fixed wiring.
- This appliance must be connected with cable of 75°C rating minimum.
- This product has passed the insulation resistance test after manufacture. If the resistance reading is low at installation, it is probably caused by moisture from the atmosphere being absorbed by the elements after the appliance has been produced. (pass at 0.01MΩ AS/NZS 3000 Wiring Rules Clause 8.3.6.3).

WARNING

This appliance must be properly earthed.

- Do not lift the appliance by the door handles.
- Prepare the cupboard opening to match your appliance measurements. (See diagrams)
- Slide appliance into the cupboard, ensuring that the supply cable (where fitted) does not kink.
- To prevent tipping, use the screws supplied to secure your appliance into the cupboard by fastening through the 4 holes to the front panel.
- Where the appliance is built into a cabinet, the cabinet must be capable of withstanding 70°C. Installation into low temperature tolerant cabinetry (e.g. vinyl coated) may result in deterioration of the low temperature coating by discolouring or bubbling.
- If the appliance is to be installed adjacent to vinyl wrapped surfaces, use an installation kit available from the vinyl-wrap supplier.
- Electrolux Home Products cannot accept responsibility for damage caused by installation into low temperature tolerant cabinets.
- After installation, test and ensure that the appliance operates correctly before handing it over to the customer.

NOTE: If a powerpoint is fitted it must be accessible with the appliance installed, as the plug must be accessible after installation.

Cabinet construction for your appliance

For the best integration within a kitchen, install this appliance in a standard 600mm wide cupboard that gives a flush fit (Figure A) with the surrounding cupboard fronts. Non-pyrolytic appliances can also be installed using a proud fit (Figure B).

IMPORTANT

For all Pyrolytic clean models, the oven must be installed as a flush fit (Figure A) to the surrounding cupboards and the “infill panel” MUST not exceed 100mm in length. This ensures a 16mm gap is maintained between the cabinet and side of the appliance to prevent the cupboard overheating.

Figure A – Flush Fit

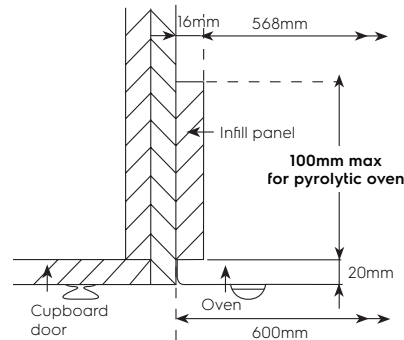
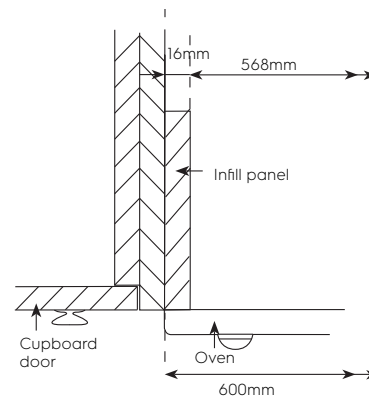

Figure B – Proud Fit



NOTE: Your appliance must be mounted on a flat horizontal surface for the full width and depth of the product

Levelling oven

Place a level in the oven as below making sure the level sits on the front and rear forms. The level needs to be correct to prevent slides from moving in or out with gravity.

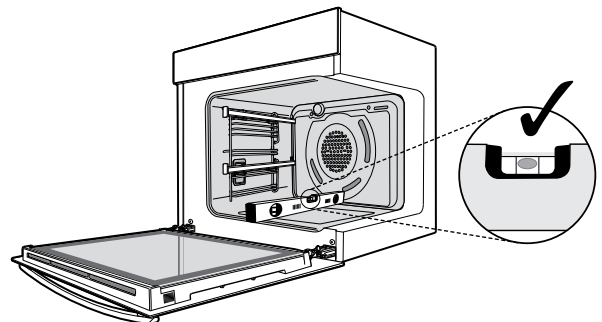

To access your detailed user manual simply scan the QR code on your smart phone or visit electrolux.com.au/support/manuals/



Installation guide

Built-in ovens

Underbench oven

Your underbench oven looks best when the control panel is directly under the benchtop. An upper infill panel may be added if the cooktop placed above the benchtop is too deep. Refer to cooktop installation instructions for required clearance between cooktop and oven.

i IMPORTANT!

Note: Dimension 'D'*

A requirement for all EVEPxxxx pyrolytic clean ovens and all Duo ovens – for proper ventilation there **MUST** be a gap at the bottom rear of the cabinet. This can be a full width opening 20mm deep. Refer to dimension "D" in relevant diagram.

Power point connection for the oven must be accessible with the appliance fully installed. If the supply cord is damaged it must be replaced by the manufacturer, its service agent or similarly qualified persons in order to avoid a hazard.

Cut-out dimensions

Type of fit	A (width)	B (height)	C (depth)
Flush fit (mm)	600	600	581 min.
Proud fit (mm)	568	590	560 min.

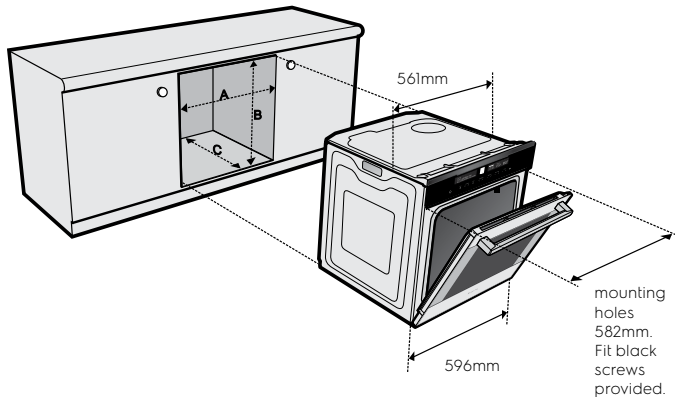

Double oven cut-out dimensions

Type of fit	A (width)	B (height)	C (depth)
Flush fit (mm)	600	1086	581 min.
Proud fit (mm)	568	1078	560 min.

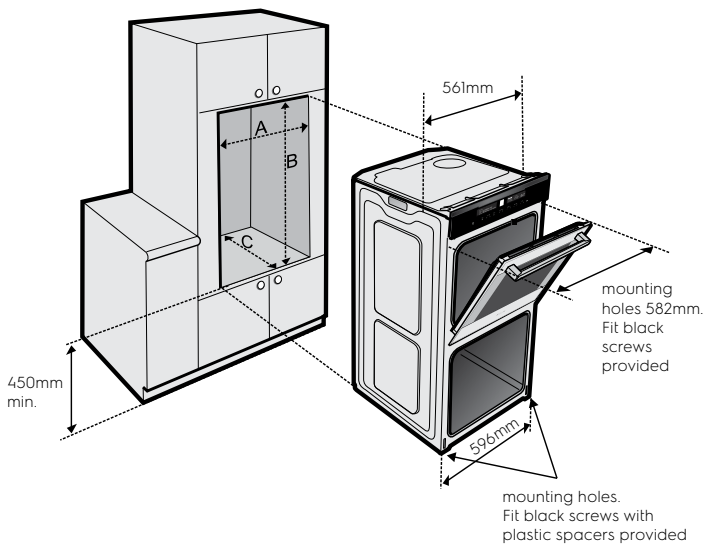

Pyrolytic underbench cut-out dimensions

Type of fit	A (width)	B (height)	C (depth)	D*
Flush fit (mm)	600	600	581 min.	20

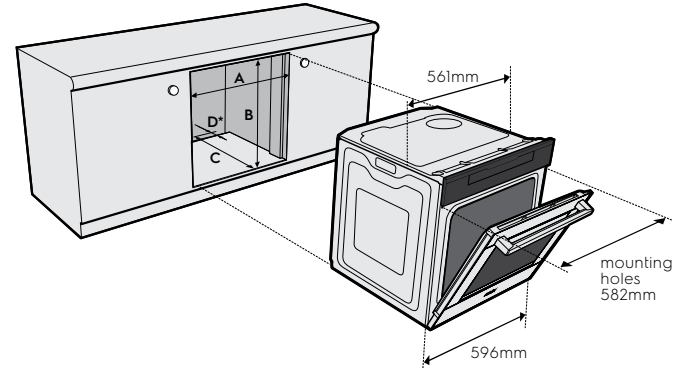

Duo oven cut-out dimensions

Type of fit	A (width)	B (height)	C (depth)	D*
Flush fit (mm)	600	893	581 min.	20

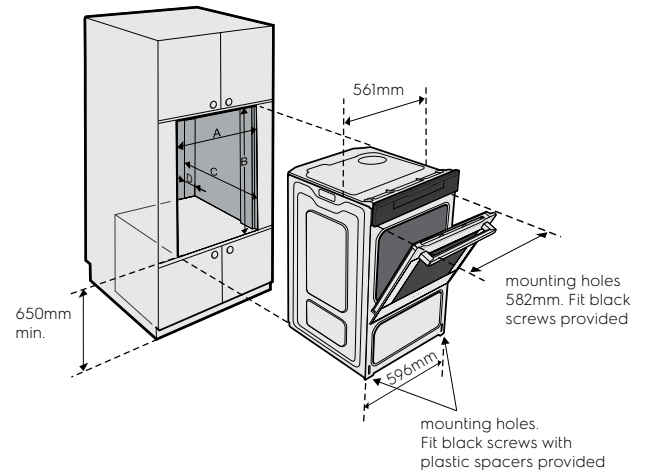

Technical specifications

Model	dimension (HxWxD)mm	electrical connection	min fuse rating	max power rating	max current rating
EVE602	597 x 596 x 568	230-240V/50Hz	16A	3.1kW	12.9A
EVE614	597 x 596 x 568	230-240V/50Hz	16A	3.1kW	12.9A
EVE616	597 x 596 x 568	230-240V/50Hz	16A	3.1kW	12.9A
EVEP614	597 x 596 x 572	230-240V/50Hz	16A	3.1kW	12.9A
EVEP616	597 x 596 x 572	230-240V/50Hz	16A	3.1kW	12.9A
EVEP618	597 x 596 x 572	230-240V/50Hz	16A	3.1kW	12.9A
EVE626	890 x 596 x 568	230-240V/50Hz	25A	5.3kW	22.1A
EVEP626	890 x 596 x 572	230-240V/50Hz	25A	5.3kW	22.1A
EVE636	1083 x 596 x 568	230-240V/50Hz	32A	6.2kW	25.8A

Hard wiring details

1. Remove terminal cover plate from rear panel of appliance.
2. Fit wires through hole in cover plate and make connections to terminals.
3. Engage wires into plastic clip. Secure plastic clip with two long silver screws (supplied in separate bag).
4. Replace cover plate onto rear panel.

