

## **CERAMIC HOBS**

WHC642BC, WHC742BC, WHC642SC,  
WHC942BC, WHC322BC

## CONGRATULATIONS

Dear customer,

Congratulations and thank you for choosing our cooktop.

We are sure you will find it a pleasure to use. Before you use the cooktop, we recommend that you read through the relevant sections of this manual, which provides a description of your appliance and its functions.

To avoid the risks that are always present when you use an appliance, it is important that the appliance is installed correctly and that you read the safety instructions carefully to avoid misuse and hazards.

We recommend that you keep this instruction booklet for future reference and pass it on to any future owners.

After unpacking the appliance, please check it is not damaged. If in doubt, do not use the appliance but contact your local customer care centre.

This appliance complies with requirements of Australian Standards AS/NZS 60335.2.6.

### Conditions of use

This appliance is intended to be used in household and similar applications such as:

- Staff kitchen areas in shops, offices and other working environments
- Farm houses
- By clients in hotels, motels and other residential type environments
- Bed and breakfast type environments
- Catering and similar non-retail applications

**Please ensure you read the instruction manual fully before you call for service, or a full service fee could be applicable.**

Record model and serial number here:

Model number:.....

Serial number:.....

PNC:.....

## CONTENTS

Important safety instructions.....	3
Product description .....	4
WHC642BC	
WHC742BC	
WHC642SC	
WHC942BC.....	5
WHC322BC	
Using your cooktop.....	6
Cleaning your cooktop .....	7
Troubleshooting.....	8
Technical data.....	8
Installing your cooktop.....	9
Warranty.....	15

Please read the user manual carefully and store in a handy place for later reference.

The symbols you will see in this booklet have these meanings:



### WARNING

This symbol indicates information concerning your personal safety.



### CAUTION

This symbol indicates information on how to avoid damaging the appliance.



### IMPORTANT

This symbol indicates tips and information about use of the appliance.



### ENVIRONMENT

This symbol indicates tips and information about economical and ecological use of the appliance.

### IMPORTANT INFORMATION THAT MAY IMPACT YOUR MANUFACTURER'S WARRANTY

Adherence to the directions for use in this manual is extremely important for health and safety. Failure to strictly adhere to the requirements in this manual may result in personal injury, property damage and affect your ability to make a claim under the Westinghouse manufacturer's warranty provided with your product. Products must be used, installed and operated in accordance with this manual. You may not be able to claim on the Westinghouse manufacturer's warranty in the event that your product fault is due to failure to adhere to this manual.

## IMPORTANT SAFETY INSTRUCTIONS

Please read the user manual carefully and store in a handy place for later reference.



### IMPORTANT

**Important – check for any damages or marks**

If you find the appliance is damaged or marked, you must report it within 7 days if you wish to claim for damage/marks under the manufacturer's warranty. This does not affect your statutory rights.



### ENVIRONMENT

**Information on disposal for users**

- Most of the packing materials are recyclable. Please dispose of those materials through your local recycling depot or by placing them in appropriate collection containers.
- If you wish to discard this product, please contact your local authorities and ask for the correct method of disposal.



### WARNING

**These warnings have been provided in the interest of safety. You MUST read them carefully before installing or using the appliance.**

- An authorised person must install this appliance and carry out servicing. (Certificate of Compliance to be retained)
- This appliance must be earthed.
- In order to avoid any potential hazard, the enclosed installation instructions must be followed.
- Do not modify this appliance.
- This appliance must not be used as a space heater.
- Ensure the appliance is switched off before cleaning. This can be done by switching off the appliance via the powerpoint or isolating switch (if available), or the switchboard.
- Do not use steam cleaners, as this may cause moisture build up.
- Always keep the appliance clean.
- Do not use the appliance as a storage area or work surface.
- Do not place or store flammable liquids, highly inflammable materials or fusible objects (e.g. plastic film, plastic, aluminium) on or near the appliance.
- Do not leave the appliance on unattended.
- This appliance is not intended for use by persons (including children) with reduced physical, sensory or mental capabilities, or lack of experience and knowledge, unless they have been given supervision or instruction concerning use of the appliance by a person responsible for their safety.
- Children should be supervised to ensure that they do not play with the appliance.
- Accessible parts will become hot when in use. To avoid burns and scalds children should be kept away.
- During use, this appliance becomes hot. Care should be taken to avoid touching hot surfaces.

- Ensure that all electrical cables are kept well clear of the appliance during use.
- Overheated fats and oils can ignite very quickly. When cooking with fat or oil do not leave the appliance unattended.
- Switch the cooking zones off after each use.
- To maintain safe operation, it is recommended that the product be inspected every 5 years by an authorised service person.
- In the event of faults with the appliance or damage to the glass ceramic (cracks, scratches or splits), the appliance must be switched off and disconnected from the electrical supply to prevent the possibility of an electric shock.



### CAUTION

**Read the following carefully to avoid damage to the appliance.**

- Before using the appliance, ensure that all packing materials are removed from the appliance. Remove stickers and film from the glass ceramic.
- Wipe away protective oil using a mild detergent and a clean damp cloth.
- Do not use harsh abrasive cleaners, powder cleaners, steel wool or wax polishes on this appliance.
- With the exception of razor blade scrapers designed for ceramic glass cleaning, (provided with some models or available to purchase through our spare parts) do not use sharp metal implements or utensils on any surface, as these may leave permanent scratches or marks.
- Always clean the appliance immediately after any food spills.
- This appliance may only be used after being built into a suitable benchtop according to the guidelines provided.
- The glass ceramic can be damaged by objects falling onto it. Care should be taken when using heavy cookware to avoid damaging the glass top and edges.
- Cookware made of cast iron, cast aluminium or with damaged bottoms can scratch the glass ceramic if dragged across the surface. Cookware should be lifted in and out of position rather than dragged or pushed.
- Food that melts and boils over can burn onto the glass ceramic surface and should be removed straight away.
- To avoid damaging the glass ceramic and cookware do not allow saucepans or frying pans to boil dry.
- Do not use the cooking zones with empty cookware or without cookware.

*NOTE: You must read these warnings carefully before installing or using the appliance. If you need assistance, contact your Customer Care Centre. The manufacturer will not accept liability, should these instructions or any other safety instructions incorporated in this book be ignored.*

## PRODUCT DESCRIPTION

WHC642BC  
WHC742BC

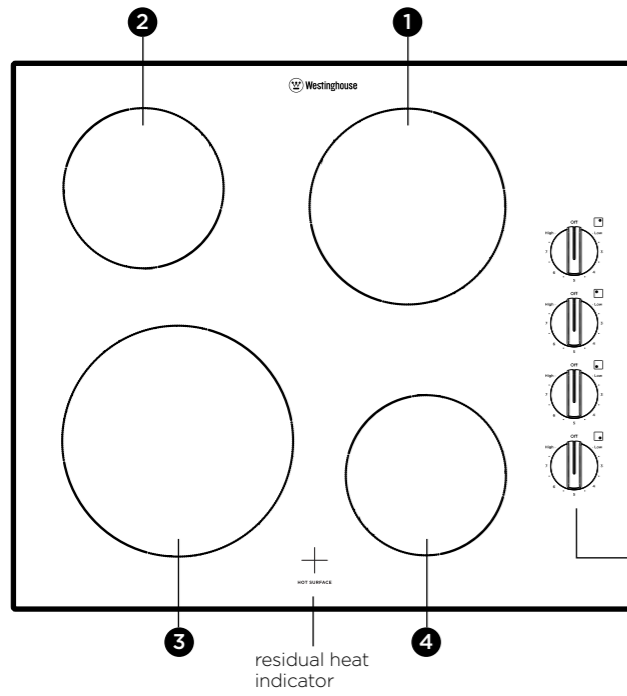

- ❶ Single 180mm diameter cooking zone 1800W
- ❷ Single 145mm diameter cooking zone 1200W
- ❸ Single 210mm diameter cooking zone 2300W
- ❹ Single 145mm diameter cooking zone 1200W

hob cooking zone control knobs

residual heat indicator

WHC642SC

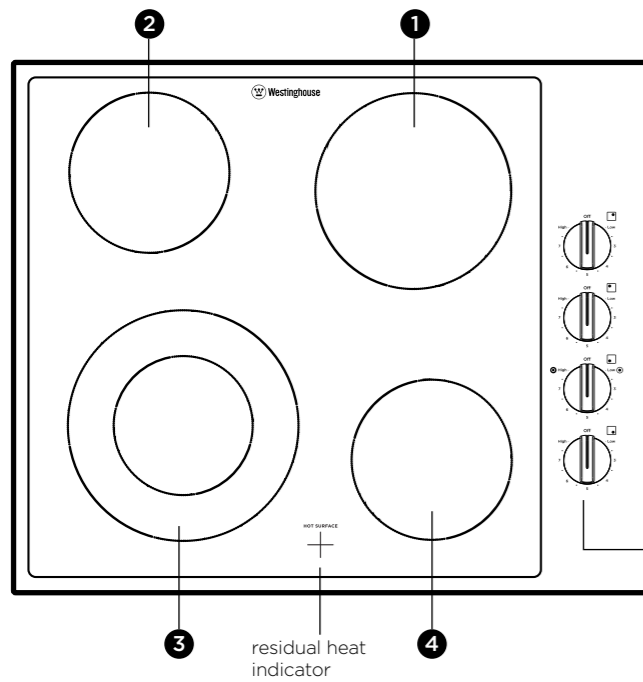

- ❶ Single 180mm diameter cooking zone 1800W
- ❷ Single 145mm diameter cooking zone 1200W
- ❸ Dual 210 diameter cooking zone 750/2200W
- ❹ Single 145mm diameter cooking zone 1200W

hob cooking zone control knobs

residual heat indicator

WHC942BC

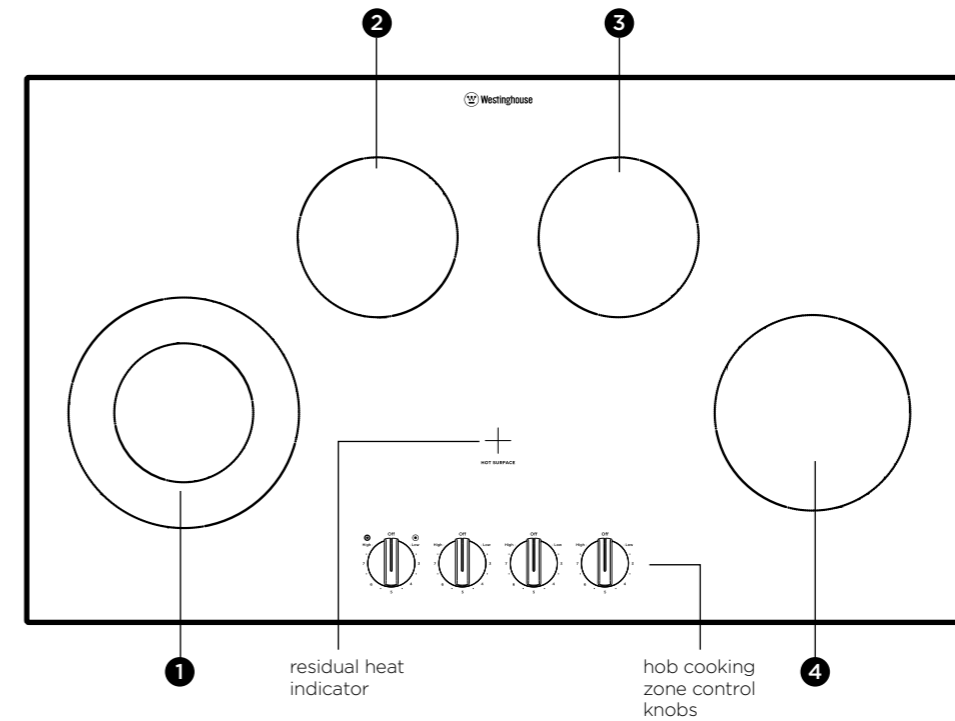

- ❶ Double 210mm diameter cooking zone 750/2200
- ❷ Single 145mm diameter cooking zone 1200W
- ❸ Single 145mm diameter cooking zone 1200W
- ❹ Single 180mm diameter cooking zone 1800W

residual heat indicator

hob cooking zone control knobs

WHC322BC

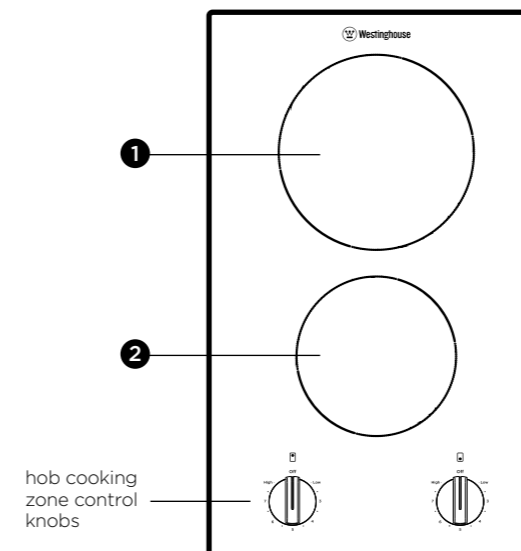

- ❶ Single 200mm diameter cooking zone 1800W
- ❷ Single 165mm diameter cooking zone 1200W

hob cooking zone control knobs

## OPERATING YOUR APPLIANCE

### **i** IMPORTANT

When a cooking zone is switched on it may hum briefly. This is a characteristic of all ceramic glass cooking zones and does not impair either the function or the life of the appliance.

#### Controlling the temperature - single zone

To increase the heat, turn the control knob clockwise.

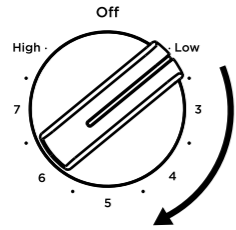

To decrease the heat, turn the control knob anti-clockwise.

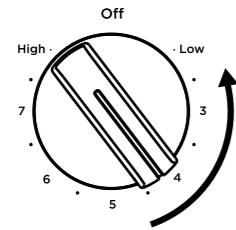

To switch off, turn the control knob to the off position.

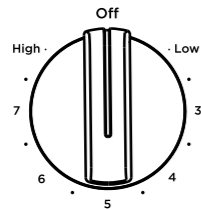

When boiling water or searing food select a high setting. As soon as steam forms or the fat or oil is hot, set a lower heat setting. To end the cooking process, turn the knob to the 'Off' position.

### **i** IMPORTANT

The Ring Control Knobs for single cooking zones can be turned either right or left.

#### Controlling the temperature - dual zone

By switching the outside ring on and off, the effective heating surface can be matched to the size of the cookware.

### **i** IMPORTANT

The inside ring must be switched on before switching on the outside ring.

To turn the outside ring on, turn the control knob clockwise past a slight resistance, as far as it will go. The inside ring must be switched on before turning on the outside ring.

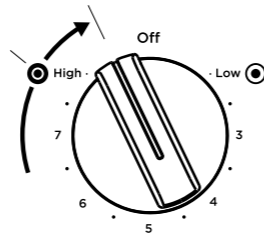

Turn the control knob anti-clockwise to reach the desired setting.

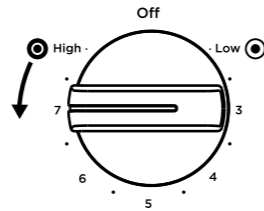

To switch off, turn the control knob to the off position.

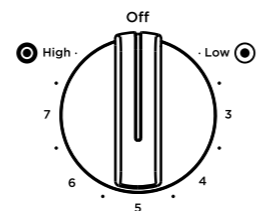

#### Cookware

For optimal results use good quality cookware with a heavy flat base. Cookware made of enamelled or with aluminium or copper bottoms can leave discolourations on the glass ceramic surface which are difficult or impossible to remove.

### **ENVIRONMENT**

- Always place the cookware on the cooking zone before it is switched on.
- If possible, always place the lids on the pans.
- Switch the cooking zones off before the end of the cooking time to take advantage of the residual heat.
- Ensure the bottom of the pan is the same size as the cooking zone you are using.

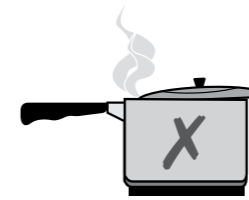

Allowing heat to escape during cooking increases cooking time and energy consumption

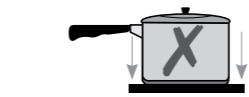

Using the wrong size pot for the cooking zone allows heat to escape



## CARE AND CLEANING

#### General cleaning

### **!** WARNING

Ensure that the appliance is turned off and all residual heat has dissipated before attempting to clean the cooktop.

### **!** CAUTION

Sharp objects and abrasive cleaning materials will damage the appliance. To prevent scratches to the surface only non-scratch scourers should be used. Damage caused by abrasive cleaning materials is not covered by the Warranty.

### **!** CAUTION

Residue from cleaning agents may damage or stain the appliance. Damage caused by residual cleaning agents is not covered by the Warranty.

Wipe the appliance with a mild detergent and a soft, damp cloth. Remove all residue after cleaning and dry with a soft cloth.

#### Removing deposits

1. Place a scraper\* on the glass ceramic surface at an angle.
2. Remove residue by sliding the blade over the surface.
3. Wipe the appliance clean with a mild detergent and a damp cloth.
4. Dry the appliance using a clean, dry cloth.

\* Provided with selected models or available for purchase as an accessory.

### **i** IMPORTANT

Sugar, food containing sugar, plastics and tin foil should be removed immediately with a scraper.

Limescale, water rings, fat splashes and metallic discolouration should be removed with a glass ceramic or stainless steel cleaner when the appliance has cooled down.

Scratches or dark stains on the glass ceramic that cannot be removed do not affect the functioning of the appliance.

## TROUBLESHOOTING

PROBLEM	CAUSES	REMEDY
The cooking zones are not functioning.	<ul style="list-style-type: none"> <li>The desired heat setting is not set.</li> <li>The fuse in the house's electrical wiring (fuse box) has been tripped.</li> </ul>	<ul style="list-style-type: none"> <li>Set the heat setting.</li> <li>Check the fuse. If the fuse continues to trip, please call an authorised electrician.</li> </ul>
The residual heat indicator is not displaying anything.	<ul style="list-style-type: none"> <li>The cooking zone was only on for a short period of time and is therefore not hot.</li> </ul>	<ul style="list-style-type: none"> <li>If the cooking zone is hot, call the Customer Service Department.</li> </ul>
Red rings, limescale or water rings, shiny metallic or other discolouration, scratches/shadows, bubbles or other miscellaneous stains on ceramic glass cooktop surfaces.	<ul style="list-style-type: none"> <li>Cooktop surface has not been cleaned correctly. Cleaning/maintenance of the cooktop surface is not covered under warranty. If a service call is placed to clean the cooktop you will be charged for the visit.</li> </ul>	<ul style="list-style-type: none"> <li>Use a ceramic glass cleaner such as Cerapol.</li> </ul>
Pitting of ceramic glass surface.	<ul style="list-style-type: none"> <li>Spillovers of liquid with high sugar content.</li> </ul>	<ul style="list-style-type: none"> <li>These types of spills must be removed immediately with a special scraper for the glass. If not, permanent damage to the cooktop glass can occur which is not covered under warranty.</li> </ul>
The residual heat indicator is not displaying anything.	<ul style="list-style-type: none"> <li>The cooking zone was only on for a short time and is therefore not hot.</li> </ul>	<ul style="list-style-type: none"> <li>If the cooking zone is supposed to be hot, call the Customer Service Department.</li> </ul>
Outer ring on double ring element won't turn on.	<ul style="list-style-type: none"> <li>Control knob has not been turned far enough.</li> </ul>	<ul style="list-style-type: none"> <li>Turn control knob clockwise, past a slight resistance. Refer instructions on page 6.</li> </ul>

If you are unable to remedy the problem by following the above suggestions, please contact your dealer or the Customer Care Department.



### WARNING

Repairs to the appliance are only to be carried out by qualified service engineers due to the risk of electric shock.



### CAUTION

If the appliance has been wrongly operated or installed, service calls may not be covered under the Warranty.

## TECHNICAL DATA

MODEL	WHC642BC	WHC742BC	WHC642SC	WHC942BC	WHC322BC					
PNC	949 163 433	949 163 437	949 163 434	949 163 438	949 163 432					
Product dimensions (w x d mm)	590x520	700x520	606x505	900x520	320x520					
Cut out dimensions (w x d mm)	560x490	560x490	560x490	880x490	300x490					
Power (kW)	6.5	6.5	6.4	6.4	3.0					
Service cord	hardwired	hardwired	hardwired	hardwired	hardwired					
Elements	No. of zones	Watts	No. of zones	Watts	No. of zones	Watts	No. of zones	Watts	No. of zones	Watts
Front left	1	2300	1	2300	2	750/2200	2	750/2200	1	1200
Rear left	1	1200	1	1200	1	1200	1	1200	1	1800
Front right	1	1200	1	1200	1	1200	1	1800		
Rear right	1	1800	1	1800	1	1800	1	1200		
Total	4	6.5	4	6.5	4	6.4	4	6.4	2	3.0

## INSTALLING YOUR APPLIANCE



### WARNING

To avoid any potential hazard, you must follow our instructions when you install your appliance. Failure to install the appliance correctly could invalidate any warranty or liability claims and lead to prosecution.

- This appliance must be installed by an authorised person according to all codes and regulations as stated in the local municipal building code and other relevant statutory regulations.
- Wiring connections must be in accordance with AS/NZS 3000 Wiring Rules and any particular conditions of the local authority.
- Wiring should be protected against mechanical failure. Refer to AS/NZS3000 clauses 3.3.2.6, 3.9, 3.10
- A means of disconnection with a contact separation of at least 3mm must be supplied in the fixed wiring.
- This appliance must be installed by an authorised person according to all codes and regulations as stated in the local municipal building code and other relevant statutory regulations.
- The minimum distances to other appliances and units are to be observed.
- Turn off the power at the mains before installing this appliance.
- Supply cords must have a temperature rating not less than 105°C.
- The surface temperature of the appliance exceeds 95°C. Underbench access must be restricted to prevent a hazard.
- The clamping joints must be installed by a qualified electrician.
- The electrical schematic must be observed.

### Electrical connection

Before connecting, check that the nominal voltage of the appliance stated on the rating plate, corresponds to the available supply voltage. The rating plate is located on the lower casing of the hob.

The hob is to be connected to the mains using a device that allows the appliance to be disconnected from the mains at all poles with a contact opening width of at least 3mm. eg. automatic line protecting cut-out, earth leakage trips or fuse. A cable with a minimum temperature rating of V90HT or higher must be used as the mains connecting cable.

The connection must be carried out as shown in the diagram. The connecting links should be fitted according to the appropriate connection diagram. The earth lead is connected to terminal.



### Connection cable

- Use the correct mains cable of type H05BB-F Tmax 90°C (or higher) for a single phase or two phase connection.
- Replace the damaged mains cable with a special cable (type H05BB-F TMAX 90°C or higher) WHC323BC: 3 x 1.5mm<sup>2</sup> with and all-pole 16A breaker. The others: 3 x 2.5mm<sup>2</sup> with an all-pole 25A breaker. Speak to your local Service Centre.
- The earth cord (green/yellow cable) must be 2cm longer than phase and neutral cable (blue and brown cables).
- The cable conditions must be in accordance with regulations and the terminal screws tightened securely.
- The connecting cable is to be secured with the mains cable cleat and the covering closed by pressing firmly (lock into place).
- Before switching on for the first time, any protective foil or stickers must be removed from the glass ceramic surface.



### IMPORTANT

Once connected to the mains supply, check that all the cooking zones are ready for use by briefly switching each on in turn at the maximum setting.

## INSTALLING YOUR APPLIANCE (CONTINUED)

### Applying the seal

- Clean the worktop around the cut-out area.
- Stick the single-sided adhesive sealing tape provided around the outside edge of the underside of the hob, ensuring that it is not stretched. The 2 ends of the tape should join in the middle of one side. Allow the tape to overlap by 2-3mm, trim, and press the 2 ends together.

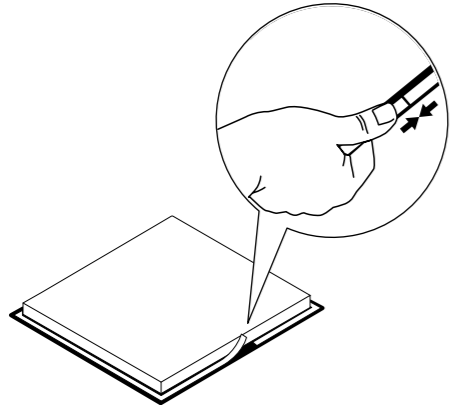

Assemble spring clips as shown, to support unit in benchtop.

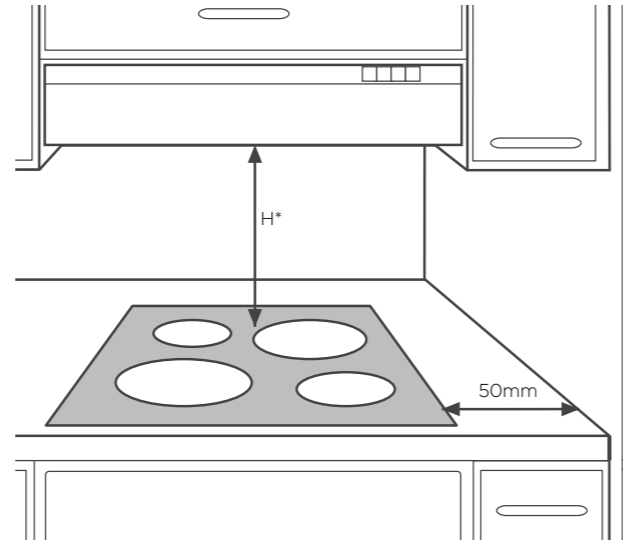
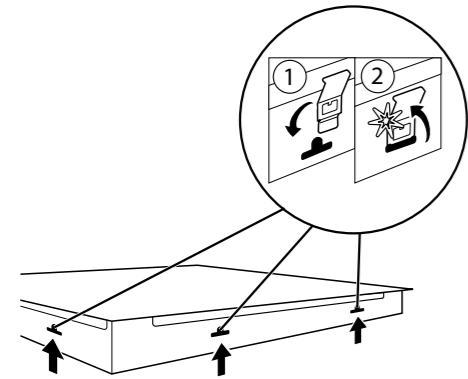

The cooktop must be installed at least 50mm from any combustible surface.

H\* - refer to rangehood manufacturers installation instructions for minimum height from cooktop.

*NOTE: The clearance must meet or exceed the minimum recommended for both the rangehood and cooktop. Refer to the rangehood installation manual.*

**WHC642BC**

**WHC642SC**

**WHC742BC**

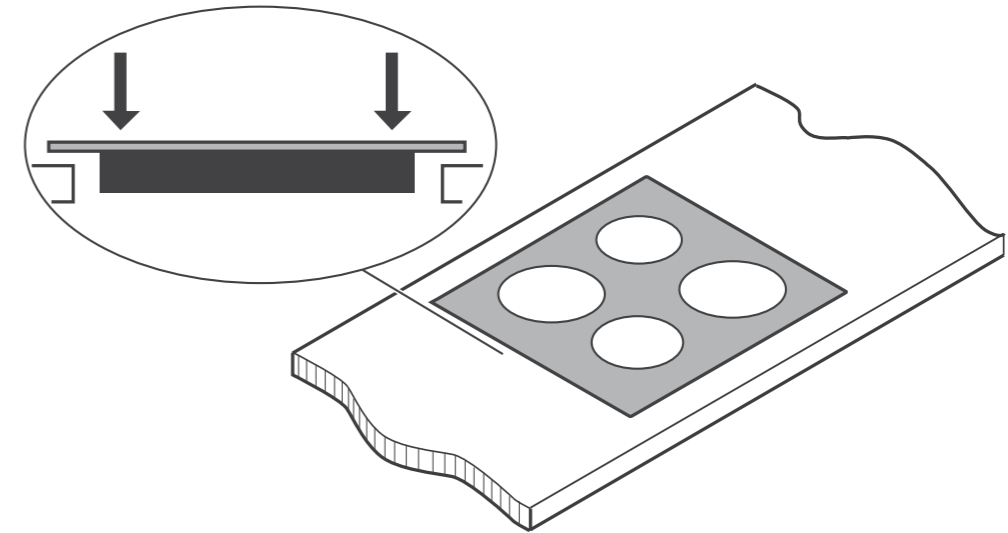
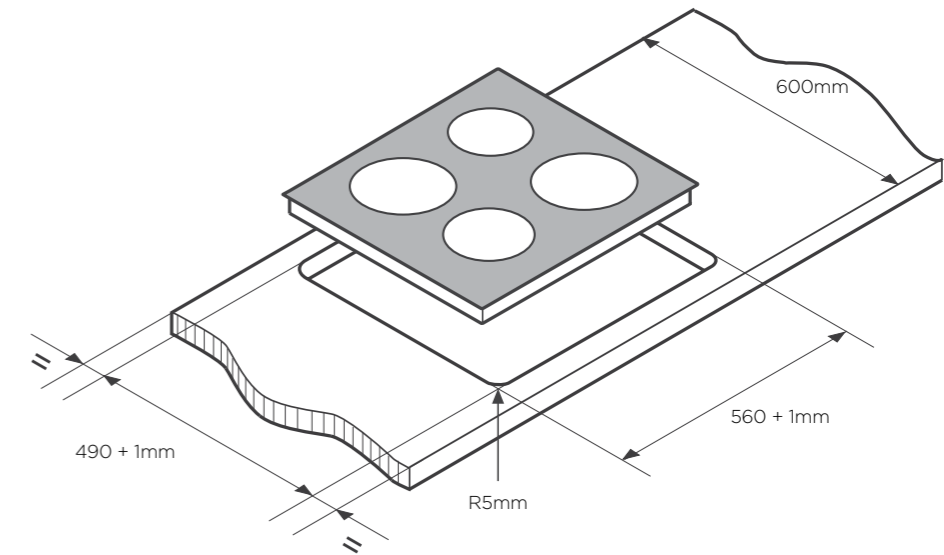



## INSTALLING YOUR APPLIANCE (CONTINUED)

WHC942BC

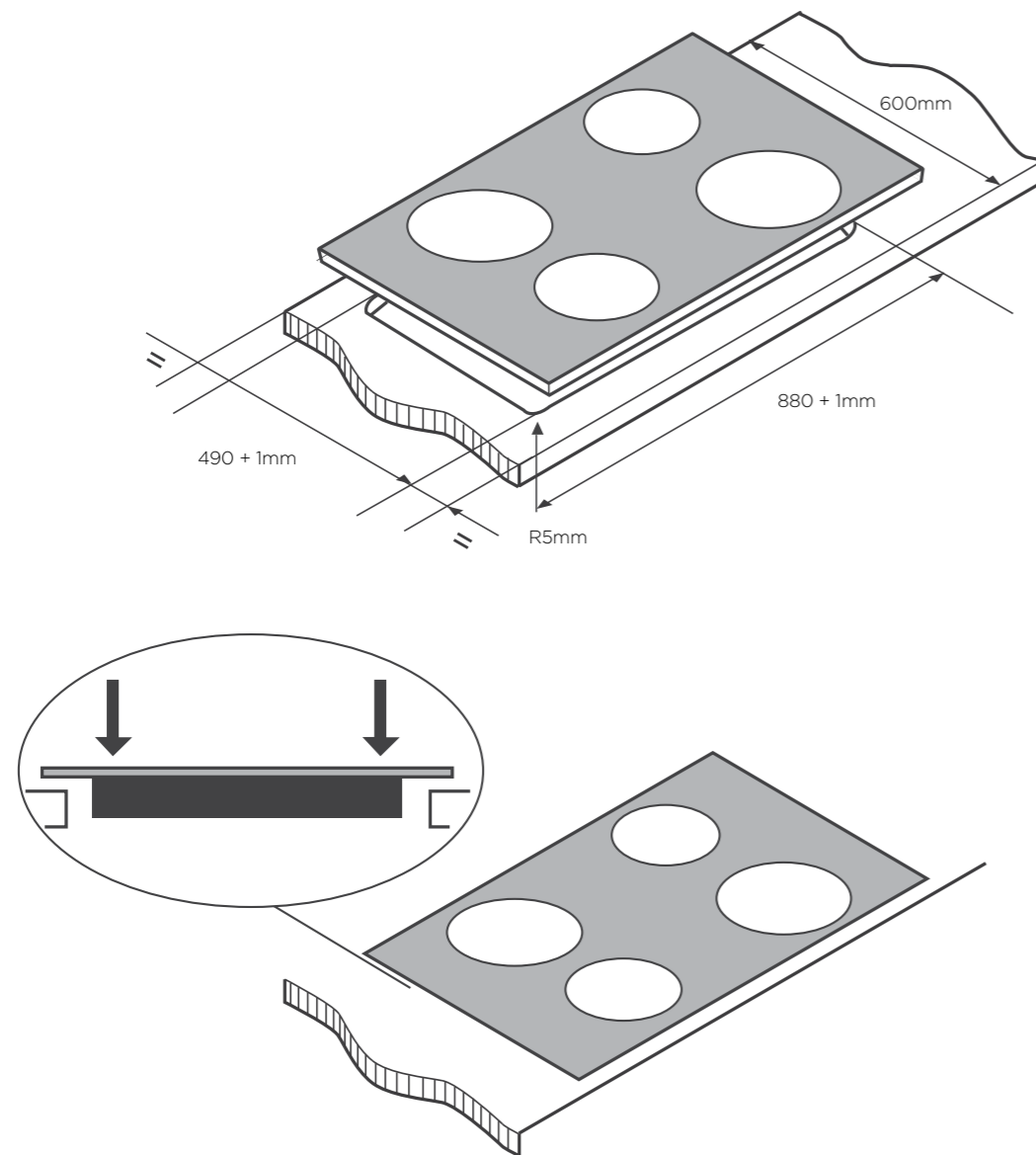

WHC322BC

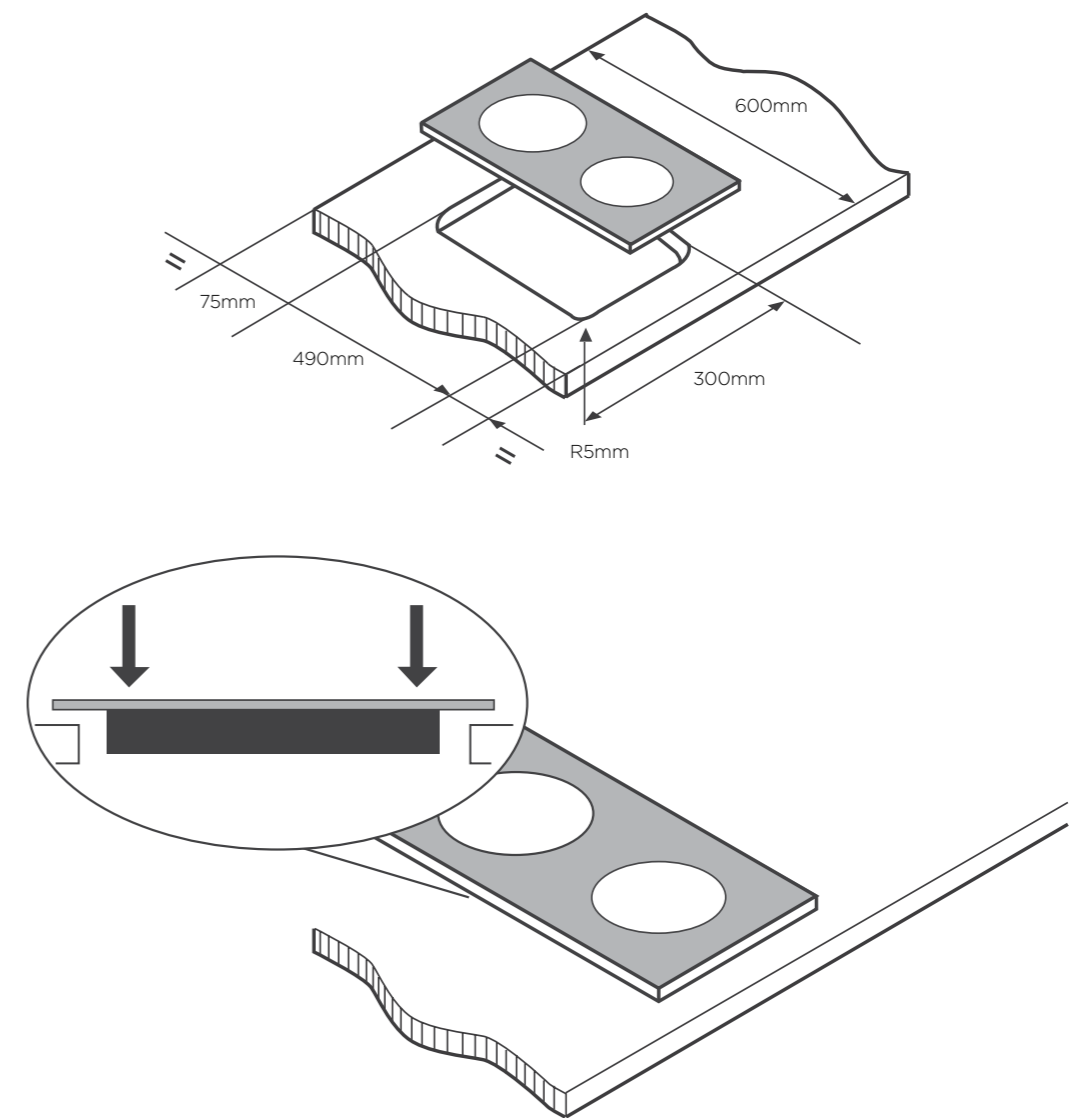

### **i** IMPORTANT

It is recommended to centre the bench cutout with equal distance front and back as shown but the product has also been certified to be installed with no clearance between the rear edge of the cooktop glass and rear wall if required. In doing so, installers still need to leave sufficient clearance to take into account that the glass dimensions are larger than the cut out.

**INSTALLING YOUR APPLIANCE (CONTINUED)**

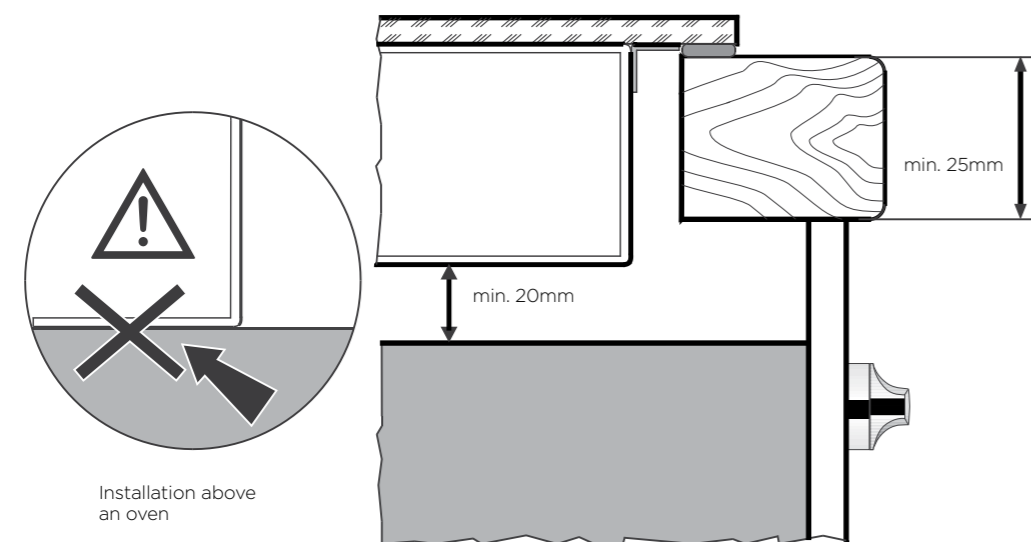
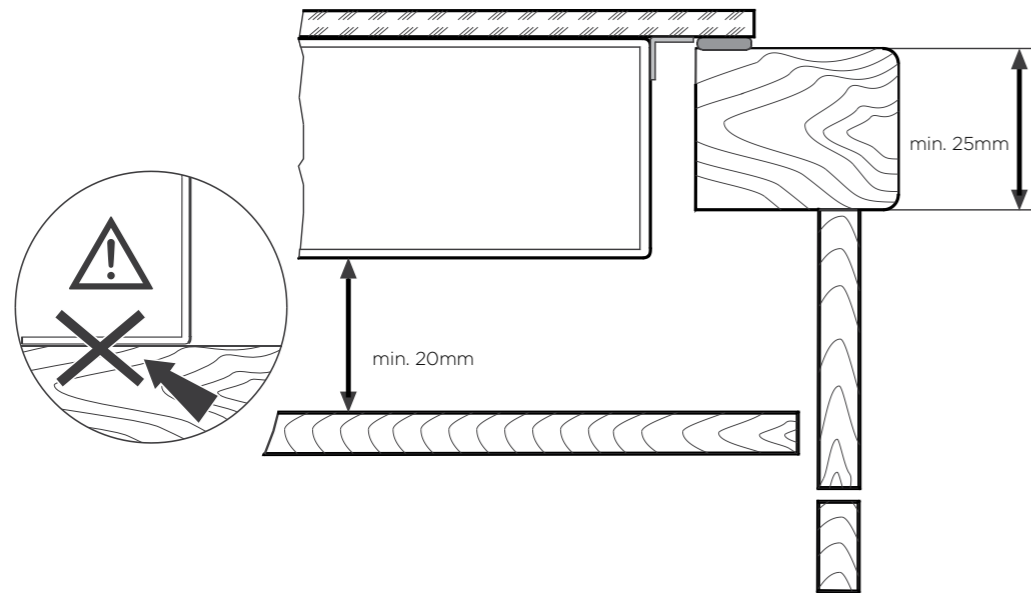

**This document sets out the terms and conditions of the product warranties for Westinghouse Appliances. It is an important document. Please keep it with your proof of purchase documents in a safe place for future reference should there be a manufacturing defect in your Appliance. This warranty is in addition to other rights you may have under the Australian Consumer Law.**

**1. In this warranty:**

- (a) 'ACL' or 'Australian Consumer Law' means Schedule 2 to the Competition and Consumer Act 2010;
- (b) 'Appliance' means any Electrolux product purchased by you and accompanied by this document;
- (c) 'ASC' means Electrolux's authorised serviced centres;
- (d) 'Westinghouse' is the brand controlled by Electrolux Home Products Pty Ltd of 163 O'Riordan Street, Mascot NSW 2020, ABN 51 004 762 341 in respect of Appliances purchased in Australia and Electrolux (NZ) Limited (collectively "Electrolux") of 3-5 Niall Burgess Road, Mount Wellington, in respect of Appliances purchased in New Zealand;
- (e) 'Warranty Period' means the period specified in clause 3 of this warranty;
- (f) 'you' means the purchaser of the Appliance not having purchased the Appliance for re-sale, and 'your' has a corresponding meaning.

**2. Application:** This warranty only applies to new Appliances, purchased and used in Australia or New Zealand and is in addition to (and does not exclude, restrict, or modify in any way) other rights and remedies under a law to which the Appliances or services relate, including any non-excludable statutory guarantees in Australia and New Zealand.

**3. Warranty Period:** Subject to these terms and conditions, this warranty continues in Australia for a period of 24 months and in New Zealand for a period of 24 months, following the date of original purchase of the Appliance.

**4. Repair or replace warranty:** During the Warranty Period, Electrolux or its ASC will, at no extra charge if your Appliance is readily accessible for service, without special equipment and subject to these terms and conditions, repair or replace any parts which it considers to be defective. Electrolux may, in its absolute discretion, choose whether the remedy offered for a valid warranty claim is repair or replacement. Electrolux or its ASC may use refurbished parts to repair your Appliance. You agree that any replaced Appliances or parts become the property of Electrolux.

**5. Travel and transportation costs:** Subject to clause 7, Electrolux will bear the reasonable cost of transportation, travel and delivery of the Appliance to and from Electrolux or its ASC. Travel and transportation will be arranged by Electrolux as part of any valid warranty claim.

**6. Proof of purchase** is required before you can make a claim under this warranty.

**7. Exclusions:** You may not make a claim under this warranty unless the defect claimed is due to faulty or defective parts or workmanship. This warranty does not cover:

- (a) light globes, batteries, filters or similar perishable parts;
- (b) parts and Appliances not supplied by Electrolux;
- (c) cosmetic damage which does not affect the operation of the Appliance;

- (d) damage to the Appliance caused by:
  - (i) negligence or accident;
  - (ii) misuse or abuse, including failure to properly maintain or service;
  - (iii) improper, negligent or faulty servicing or repair works done by anyone other than an Electrolux authorised repairer or ASC;
  - (iv) normal wear and tear;
  - (v) power surges, electrical storm damage or incorrect power supply;
  - (vi) incomplete or improper installation;
  - (vii) incorrect, improper or inappropriate operation;
  - (viii) insect or vermin infestation;
  - (ix) failure to comply with any additional instructions supplied with the Appliance;

In addition, Electrolux is not liable under this warranty if:

- (a) the Appliance has been, or Electrolux reasonably believes that the Appliance has been, used for purposes other than those for which the Appliance was intended, including where the Appliance has been used for any non-domestic purpose;
- (b) the Appliance is modified without authority from Electrolux in writing;
- (c) the Appliance's serial number or warranty seal has been removed or defaced

**8. How to claim under this warranty:** To enquire about claiming under this warranty, please follow these steps:

- (a) carefully check the operating instructions, user manual and the terms of this warranty;
- (b) have the model and serial number of the Appliance available;
- (c) have the proof of purchase (e.g. an invoice) available;
- (d) telephone the numbers shown below.

**9. Australia:** For Appliances and services provided by Electrolux in Australia: Electrolux goods come with guarantees that cannot be excluded under the Australian Consumer Law. You are entitled to a replacement or refund for a major failure and for compensation for any other reasonably foreseeable loss or damage. You are also entitled to have the Appliance repaired or replaced if the Appliance fails to be of acceptable quality and the failure does not amount to a major failure. 'Acceptable quality' and 'major failure' have the same meaning as referred to in the ACL.

**10. New Zealand:** For Appliances and services provided by Electrolux in New Zealand, the Appliances come with a guarantee by Electrolux pursuant to the provisions of the Consumer Guarantees Act, the Sale of Goods Act and the Fair Trading Act. Where the Appliance was purchased in New Zealand for commercial purposes the Consumer Guarantee Act does not apply.

**11. Confidentiality:** You accept that if you make a warranty claim, Electrolux and its agents including ASC may exchange information in relation to you to enable Electrolux to meet its obligations under this warranty.

**Important Notice**

Before calling for service, please ensure that the steps listed in clause 8 above have been followed.

<b>AUSTRALIA</b>	<b>FOR SERVICE</b> or to find the address of your nearest authorised service centre in Australia <b>PLEASE CALL 13 13 49</b> <small>For the cost of a local call</small>	<b>FOR SPARE PARTS</b> or to find the address of your nearest spare parts centre in Australia <b>PLEASE CALL 13 13 50</b> <small>For the cost of a local call</small>
<b>NEW ZEALAND</b>	<b>FOR SERVICE</b> or to find the address of your nearest authorised service centre in New Zealand <b>PLEASE CALL 0800 10 66 10</b>	<b>FOR SPARE PARTS</b> or to find the address of your nearest spare parts centre in New Zealand <b>PLEASE CALL 0800 10 66 20</b>



**For more information on all Westinghouse appliances, or for dimension and installation information, call into your retailer, phone or email our customer care team or visit our website:**

**AUSTRALIA**

phone: 13 13 49

email: [customercare@electrolux.com.au](mailto:customercare@electrolux.com.au)

web: [westinghouse.com.au](http://westinghouse.com.au)

**NEW ZEALAND**

phone: 0800 10 66 10

email: [customercare@electrolux.co.nz](mailto:customercare@electrolux.co.nz)

web: [westinghouse.co.nz](http://westinghouse.co.nz)

**Westinghouse. We are part of the Electrolux family.  
Share more of our thinking at [www.electrolux.com](http://www.electrolux.com)**

 and WESTINGHOUSE are trademarks of Westinghouse Electric Corporation.  
Used under license. All Rights Reserved.

P/No A19136401 Issue A

© 2019 Electrolux Home Products Pty Ltd.  
ABN 51 004 762 341  
WMAN\_CHOB\_Nov19